

Precision leading and feed spindle machines, mature technology, fully equipped, easy to operate

Facts that impress in terms of quality, performance and price

- ▶ Tempered and polished z-axis guideway
- ▶ Spindle collet Camlock DIN ISO 702-2 no. 6
- ▶ Precision slide
- ▶ Hand wheels with adjustable fine scaling 0.04 / 0.02 mm
- ▶ Quadruple tool holder
- ▶ All guides adjustable using cleats
- ▶ Adjustment range top slide $\pm 90^\circ$
- ▶ Guaranteed concentricity of spindle nose better than 0.015 mm
- ▶ Main spindle runs in oil bath
- ▶ Gearwheels smooth running, tempered and ground borne on 2 re-adjustable precision taper rollers
- ▶ Hand wheels decoupled and approved in line with EN 23125
- ▶ Two-channel CW/CCW switch approved in line with EN 23125
- ▶ Switch with lifecycle calculation, approved in line with EN ISO 13849
- ▶ All metric pitches in range from 0.2 to 14 mm/rev and all inch pitches in range of 72 - 2 turns per inch configurable on control panel without replacing the interchangeable gear wheels thanks to gear shift
- ▶ Right-handed/left-handed rotation switchable on bed slide, switchable via switching spindle
- ▶ Central lubrication in bed slide
- ▶ Chassis and machine bed single-piece cast meehanite
- ▶ Leading spindle cover
- ▶ Emergency stop device with foot pedal
- ▶ Safety hand wheels with release function in the X and Z axis
- ▶ Tailstock adjustable ± 10 mm for turning spheres
- ▶ Tailstock spindle sleeve and handwheel with adjustable fine scaling 0.025 mm
- ▶ Fast, easy adjustment without tools thanks to clamping lever
- ▶ Grey cast iron prism bed with strong ribbing, induction tempered and precision ground
- ▶ Coolant system featuring separate coolant tank, fill level display and oil trap; easy and complete draining and cleaning as per DIN
- ▶ LED machine lamp in chip guard:
- ▶ **TH 4210D / TH 4215D:**
- ▶ **Digital position display DPA21**
 - › User-friendly membrane keyboard, splash water protected, sealed and dazzle free
 - › Sensor supplied for acquiring spindle speeds
 - › Glass scales

Control Cabinet

- › 24 Volt DC Power Supply
- › All contactors und relays by Siemens or Schneider



Fig.: TH 4210D - Shown with optional lathe chuck



Technical specifications, accessories and dimensions

Model	TH 4210	
Article no.	3462050	
	9,990.00	
Model	TH 4210D	TH 4215D
Article no.	3462055	3462070

Technical specifications		
Electrical connection	400 V / 3 Ph ~ 50 Hz	
Total rated value	4.6 kW	
Coolant pump motor	100 W	
Spindle		
Drive motor	4.5 kW	
Spindle taper	MT 6	
Spindle seat	Camlock DIN ISO 702-2 No. 6	
Spindle bore, bar passage diameter	Ø 52 mm	
Quick change tool holder height	20 mm	
Work area		
Centre height	210 mm	
Centre width	1 000 mm	1 500 mm
Swing Ø over machine bed	420 mm	
Swing in the bed bridge	590 mm	
Turning length in bed bridge	260 mm	
Swing over cross slide	250 mm	
Bed width	250 mm	
Speed range		
Spindle speed	45 - 1 800 rpm	
Number of speeds	16 speeds	
Travel		
Top slide travel	140 mm	
Cross slide travel	230 mm	
Feeds and pitches		
Longitudinal feed within the range	0.05 - 1.7 mm/rev (17 feeds)	
Cross feed within	0.025 - 0.85 mm/rev (17 feeds)	
Pitch - metric in range	0.2 - 14 mm/rev (39 pitches)	
Pitch - inch in range	72 - 2 turns/inch (45 pitches)	
Diametral pitch in range	8 - 44 turns/π (21 pitch)	
Modular thread in range	0.3 - 3.5 mm x π (18 thread)	
Tailstock		
Tailstock seat	MT 4	
Tailstock spindle sleeve diameter / stroke	Ø 50 mm / 120 mm	
Dimensions		
Length	1 940 mm	2,440 mm
Width x height	915 x 1 375 (DPA 1 600) mm	
Weight	1 160 kg	1 340 kg

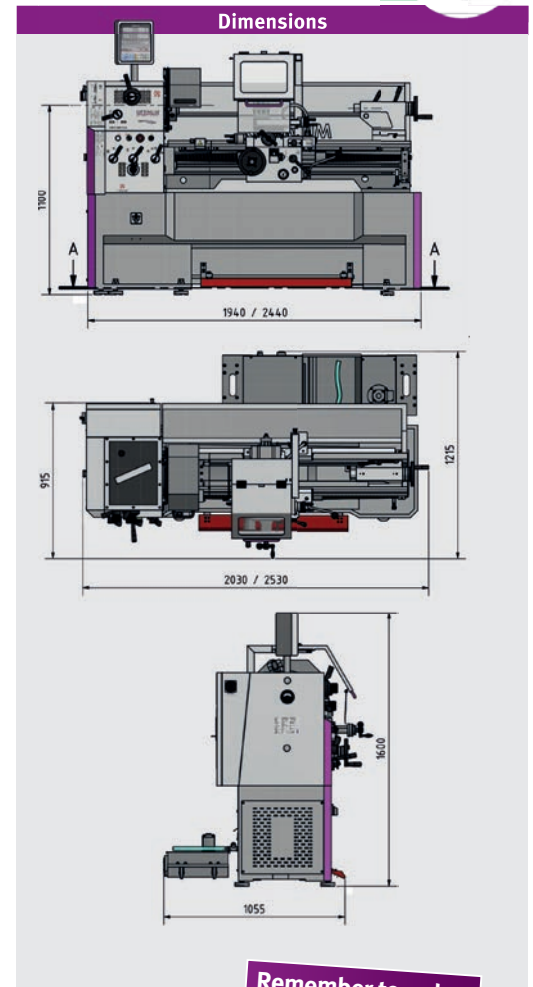

Scope of supply

- › Steady rest passageway Ø 15 - 145 mm
- › Follow rest passageway Ø 10 - 75 mm
- › LED machine lamp
- › Reduction sleeve MT 6 - MT 4
- › One fixed and one alloyed centre MT 4
- › Replaceable gear set
- › Gear wheels for threading gauge (metric)
- › Position stop with granular adjustment
- › Machine initially filled with premium grade oil
- › Operating tool
- › Quad tool holder max. 20 mm

Lathe chuck	Art no.
OPTIMUM cast lathe chucks	
Three-jaw lathe chuck Ø 250 mm no. 6, centric	3442765
Four-jaw lathe chuck Ø 250 mm no. 6, centric	3442852
Four-jaw lathe chuck Ø 250 mm no. 6, individual	3442884
BISON lathe chucks	
Three-jaw lathe chuck Ø 250 mm no. 6, cast Centre clamping	3450330
Four-jaw lathe chuck Ø 250 mm no. 6, cast Centre clamping	3450380
Three-jaw lathe check Ø 250 mm no. 6, steel Centre clamping	3450530
Four-jaw lathe chuck Ø 250 mm no. 6, steel Centre clamping	3450580
› Information about lathe chucks from page 188	

Accessories	Art no.
Quick change tool holder SWH 5-B	3384305
Factory assembly SWH 5-B	9000400
Spare tool holder 25 x 120 Type D for square	3384306
Spare tool holder 32 x 130 type H for round chisels	3384324
Lathe tool set HM 20 mm, 5-part (see page 192)	3441670
Lathe tool set HM 20 mm, 5-part (see page 192)	3441617
Vibration damper SE 2 (6 pcs. needed)	3381016
Vibration damper SE 85 (6 pcs. needed)	3352982
Clamping block set 20-05	3440654
Universal collet chuck device 5C	3441507
› More accessories for lathes from page 184	