

Machine lifts

MH Series - Machine lift

- ▶ For safe lifting of heavy loads
- ▶ Stable, welded steel design for demanding applications
- ▶ Lowering speed infinitely adjustable thanks to release screw with granular control
- ▶ Small and compact design



MH 3



MH 8



MH 10



MH 20

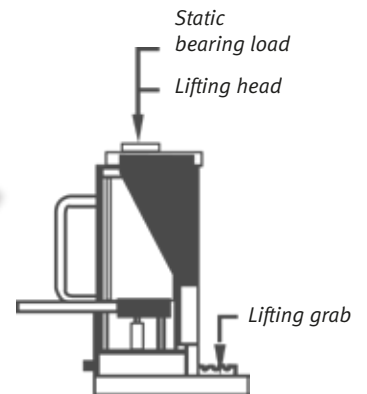

Scope of delivery MH 3:

- > Height-adjustable lifting grab

Scope of delivery MH 8:

- > Height-adjustable lifting grab

Scope of delivery MH 10:

- > Spindle thread

Scope of delivery MH 20:

- > Height-adjustable lifting grab
- > Spindle thread

| Model | MH 3 | MH 8 | MH 10 | MH 20 |
|---|--------------------|--------------------|----------------------|--------------------|
| Art. no. | 6190003 | 6190008 | 6190010 | 6190020 |
| Technical specifications | | | | |
| Lifting head load lifting capacity | 3 t | 8 t | 7.5 t | 15 t |
| Underride height of lifting head | 233 mm | 261 mm | 320 mm | 325 mm |
| Lifting head load stroke | 140 mm | 140 mm | 80 mm | 140 mm |
| Max. load lifting capacity lifting grab | 3 t | 8 t | 6 t | 12 t |
| Lifting grab underride heights | 15 / 75 / 135 mm | 20 / 85 / 150 mm | 35 mm | 40 / 100 mm |
| Lifting grab stroke | 140 mm | 140 mm | 160 mm | 140 mm |
| Max. static bearing load | 3 t | 8 t | 10 t | 20 t |
| Support height min. static bearing load | 233 mm | 261 mm | 320 mm | 325 mm |
| Support height max. static bearing load | 373 mm | 401 mm | 400 mm | 465 mm |
| Dimensions (L x W x H) | 250 x 231 x 233 mm | 271 x 251 x 261 mm | 160 x 245.5 x 320 mm | 296 x 372 x 325 mm |
| Weight | 21 kg | 28 kg | 25 kg | 31 kg |