

Lathes for DIY.

TU 2406V with electronic speed control

Facts that impress in terms of quality, performance and price

- ▶ Precision workmanship
- ▶ Tempered and polished z-axis guideway
- ▶ Guaranteed concentricity of spindle nose better than 0.009 mm
- ▶ Roll-milled trapezoidal spindles
- ▶ Leading spindle borne on two sintered bearings
- ▶ Two tapered roller bearings in P5 quality
- ▶ Precision slide
- ▶ Hand wheels with adjustable fine scaling 0.04 / 0.01 mm
- ▶ Quadruple tool holder
- ▶ All guides adjustable using cleats
- ▶ Chuck concentricity better than 0.05 mm
- ▶ Leading spindle for thread tapping or automatic longitudinal turning
- ▶ Right-handed/left-handed rotation switchable via control panel
- ▶ Tailstock adjustable ± 5 mm for turning spheres
- ▶ Tailstock spindle sleeve and handwheel with adjustable fine scaling 0.02 mm
- ▶ Fast, easy adjustment without tools thanks to clamping lever
- ▶ Emergency stop button
- ▶ Thrust bearings
- ▶ Comprehensive range of accessories
- ▶ Three-jaw lathe chuck included in standard scope of delivery
- ▶ Lasting value

TU 2406 V

- ▶ Speed change easily adjustable via potentiometer
- ▶ Digital speed display
- ▶ EMC filter class C1



Accessories

Machine chassis

Art. no. 3440409

Vibration dampers machine base SE 1

(6 pcs. needed)

Art no. 3381012

Levelling platen SE 55

(6 pcs. needed)

Art no. 3352981

Fig.: TU 2406V with optional machine chassis

Fig.: TU 2406

Technical specifications, accessories and dimensions

Model	TU 2406	TU 2406V**
Article no. (230 V)	3420350	3420355
Article no. (400 V)	3420353	-
Technical specifications		
Electrical connection	230 V / 1 Ph ~ 50 Hz 400 V / 3 Ph ~ 50 Hz	230 V / 1 Ph ~ 50 Hz
Drive motor	750 W	1.1 kW
Spindle		
Spindle taper	MT 3	
Spindle seat	cylindrical Ø 52 mm	
Spindle bore, bar passage diameter	Ø 21 mm	
Quadruple tool holder mounting height	14 mm	
Work area		
Centre height	125 mm	
Centre width	550 mm	
Swing Ø over machine bed	250 mm	
Bed width	135 mm	
Speed range		
Spindle speed	125 - 2 000 rpm	150 - 2 500 rpm
Number of speeds	6 speeds	2-speed, electronic speed control
Travel		
Top slide travel	75 mm	
Cross slide travel	120 mm	
Pitches		
Pitch - metric in range	0.4 - 3.5 mm/rev (14 pitches)	
Pitch - inch in range	44 - 10 turns/inch (12 pitches)	
Tailstock		
Tailstock seat	MT 2	
Tailstock - quill stroke	70 mm	
Dimensions		
Length x width x height	1 090 x 594 x 484 mm	
Weight	125 kg	

Lathe chucks and accessories	Art no.
Four-jaw lathe chuck Ø 125 mm, centre clamping (Chuck flange 3440511 required)	3442812
Four-jaw lathe chuck Ø 125 mm, individual clamping (Chuck flange 3440511 required)	3442874
Chuck flange lathe chuck Ø 125 mm (lathe chuck 3442812/3442874)	3440511
Clamping disc Ø 220 mm	3440552
› Information about lathe chucks from page 184	

Accessories	Art no.
Steady rest passageway max. Ø 50 mm	3441315
Follow rest passageway max. Ø 34 mm	3441310
Quick change tool holder SWH 1-A	3384301
Factory assembly SWH 1-A	9000401
Spare tool holder 20 x 90 type D for square chisels	3384302
Spare tool holder 20 x 85 type H for round chisels	3384321
Lathe tool set 10 mm, 11-part (see page 189)	3441602
Lathe tool set 12 mm, 11-part (see page 189)	3441603
Lathe tool set 12 mm, 5-part (see page 189)	3441666
Lathe tool set 12 mm, 5-part "Made in Germany"	3441212
Information on „Lathe tool set“ from page 190	
Collet chuck ER 25, cylindrical	3440505
Collet chuck ER 32, short taper	3440506
› More accessories for lathes from page 188	

*Important information on „General notes on operating our machines“ on page 253

**The lathe (frequency converter) complies with the DIN EN 55011 standard: class C1 - Note for operation with frequency converter on page 253



Dimensions

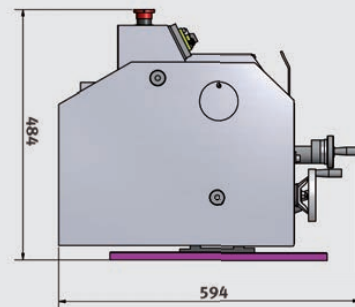
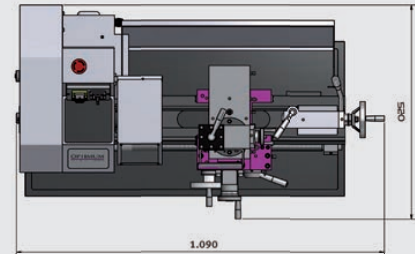

Scope of supply
› Three-jaw lathe chuck Ø 125 mm,
› Centre clamping
› Fixed centre MT 2 and MT 3
› Splashguard
› Chip tray
› Quadruple tool holder
› Replaceable gear set
› Operating tool

Accessories	Art no.
Digital position display DRO 5 incl. 3 magnetic sensors	3383975
Magnetic strip length 1 100 mm	3383978
Factory assembly	9000420
› Information about position display on page 252	