

Metal band saw with pivoting saw head. S 275NV with continuously adjustable saw band speed

Facts that impress in terms of quality, performance and price

- ▶ Low-noise running action
- ▶ Rugged cast design
- ▶ Excellent cutting precision thanks to vibration-free action
- ▶ Saw band lowering via hydraulic cylinder continuously adjustable by throttle valve
- ▶ Microswitch for automatic limit position cut-off
- ▶ Coolant system
- ▶ Equipped as a factory standard with bi-metal saw blade
- ▶ Adjustable material stop for batch work
- ▶ Easily legible scale for adjusting the angle
- ▶ Overload protection

S 275N

- ▶ Motor circuit switch
- ▶ Two switchable speeds

S 275NV

- ▶ Continuously adjustable saw band speed 20 - 90 m/min.
- ▶ Speed change possible during operation



Pressure gauge

- Easy and precise checking of the saw band tension

Ball-bearing borne saw band guide

Quick clamping vice

- Adjustable via hand wheel
- Workpiece is clamped using a handy quick-clamping lever

Machine chassis

- Robust

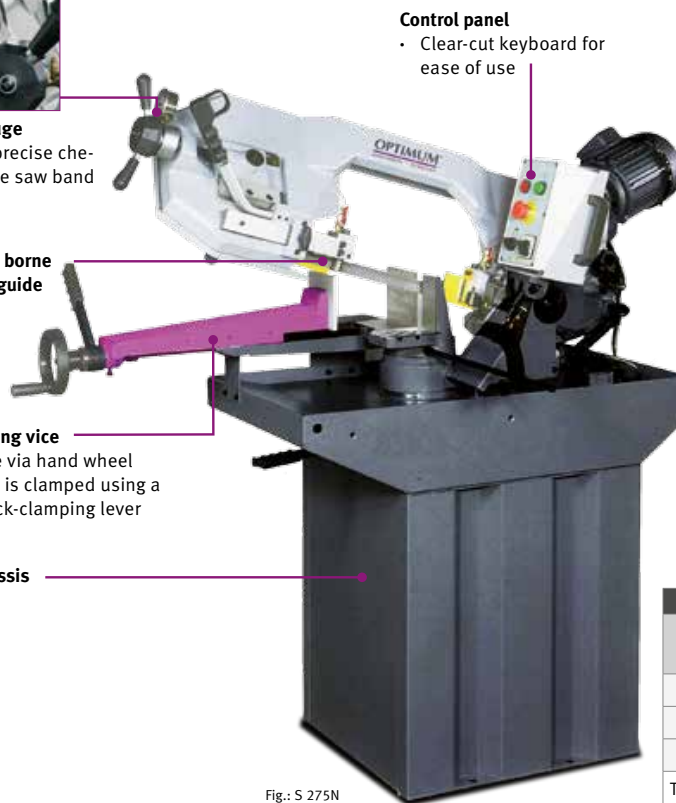

Control panel

- Clear-cut keyboard for ease of use

Fig.: S 275N

Model	S 275N	S 275NV
Article no.	3300260	3300265
Technical specifications		
Electrical connection	400 V / 3 Ph ~50 Hz	230 V / 1 Ph ~50 Hz
Motor output	1.1 kW	1.5 kW
Coolant pump motor	90 W	
General instructions		
Lifting the saw head	manual	
Feed	continuously variable	
Saw band speed	45 / 90 m/min	20 - 90 m/min
Saw band dimensions	2,480 x 27 x 0.9 mm	
Cutting angle	0° to 60°	
Net weight	185 kg	185 kg

The metal-cutting bandsaw (frequency converter) complies with the DIN EN 55011 standard: class A

Dimensions

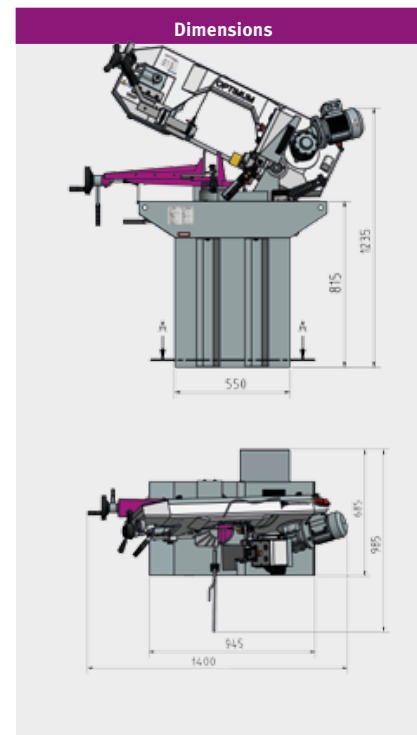

Scope of Delivery

- Material stop
- Bi-metal saw band
- Machine chassis
- Coolant pump

Cutting areas

0°	Ø 225 mm	150 mm	150 x 230 mm
45°	Ø 145 mm	145 mm	145 x 180 mm
60°	Ø 90 mm	90 mm	90 x 120 mm

The cutting area was determined for a full section.
The cutting range can be larger in case of cut-off sections.

Saw bands HSS bi-metal M 42

Teeth per inch	Tooth angle	Art.no.
5 - 8 tpi	0°	3357511
5 - 8 tpi	6°	3357512
6 - 10 tpi	0°	3357524
6 - 10 tpi	6°	3357510
10 - 14 tpi	0°	3357525

Saw band set HSS bi-metal M 42

1 pc. Saw band 6 - 10 tpi; 0°	3357504
1 pc. Saw band 5 - 8 tpi; 0°	
1 pc. Saw band 5 - 8 tpi; 6°	

„General saw band information“ on page 182