

Universal drilling/milling machine with digital position display DRO 5 and cast machine chassis. MB 4PV with continuously variable electronically controlled drive

Facts that impress in terms of quality, performance and price

- ▶ Heavy, solid cast design
- ▶ Smooth action due to polished gearwheels running in an oil sump
- ▶ Clockwise/Anti-clockwise rotation
- ▶ Automatic spindle sleeve feed with manual fine feed
- ▶ Motorised positioning of the Z axis
- ▶ Gear head pivots through $\pm 60^\circ$
- ▶ Adjustable wedge rails
- ▶ Drilling depth stop
- ▶ Drilling/Thread tapping function

MB 4P:

- ▶ Two-stage industrial quality electric motor
- ▶ Large speed range from 95 - 3,200 rpm thanks to 12 switchable speeds
- ▶ DRO 5

MB 4PV:

- ▶ Large speed range from 60 - 2,760 rpm thanks to 2 continuously variable speeds
- ▶ Single-speed, premium, industrial electric motor
- ▶ DRO 5 with speed display

OPTI Control panel

- Digital 3-axis position display
- › Control panel for controlling:
 - › Z axis height adjustment
 - › Milling/thread tapping operating mode
 - › Spindle direction of rotation
 - › Machine lamp
 - › Coolant pump
 - › Emergency stop button

MB 4P

- › Step switch of drive motor

MB 4PV

- › Rev counter
- › Potentiometer for continuous speed control

Protective screen

- Height-adjustable
- Generously dimensioned
- Microswitch

X axis

- Motorised table feed
- Continuously variable speed control
- Rapid traverse
- Clockwise/Anti-clockwise rotation

XY table

- Solid and generously dimensioned
- Precise surface finish
- With T-grooves
- Adjustable wedge rails
- Adjustable limit stops

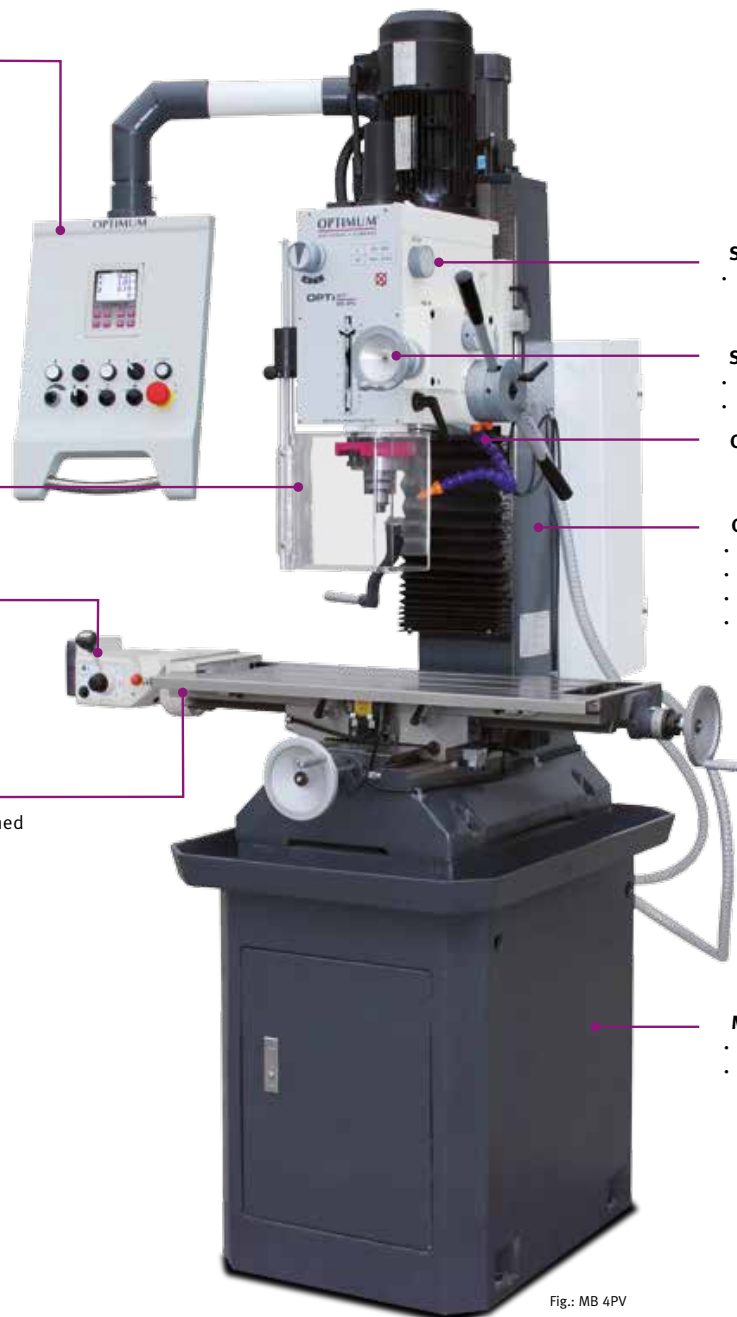

- Spindle quill feed**
- Automatic

- Spindle sleeve feed**
- Handwheel
 - Easy to operate

Coolant system

Column

- Solid dovetail guide
- Hand shaved
- Maximum stability
- Greatest possible precision

Machine chassis

- Solid cast stand
- Chip channel

Fig.: MB 4PV

Technical specifications, accessories and dimensions

Model	MB 4P	MB 4PV
Article no.	3338460	3338465
Technical data		
Electrical connection	400 V / 3 Ph ~50 Hz	230 V / 1 Ph ~50 Hz
Motor output	1.1 / 1.5 kW	1.5 kW
Drilling/milling output		
Drilling performance steel (S235JR)	Ø 32 mm	Ø 24 mm
Continuous drilling performance steel (S235JR)	Ø 28 mm	Ø 20 mm
Max. sensor head size	Ø 63 mm	Ø 63 mm
Max. shaft milling cutter size	Ø 28 mm	Ø 26 mm
Spindle holder		
Spindle sleeve stroke	120 mm	
Spindle holder	MT 4	
Spindle sleeve diameter	75 mm	
Throat	258 mm	
Tightening bar	M 16	
Drilling/milling head		
Swivel range	± 45°	± 45°
Spindle speeds	95 - 3,200 rpm	60 - 2,760 rpm
Gears	2 x 6 speeds	2 gears, electronically controlled
XY table		
Clearance spindle to XY table max.	420 mm	
Table length x width	800 x 240 mm	
T-groove size/amount/spacing	14 mm / 3 / 80 mm	
Automatic spindle sleeve feed	0.1 / 0.18 / 0.26 mm/U	
Strokes		
X axis automatic / manual	560 mm / 480 mm	
Y axis manual	195 mm	
Z axis manual	350 mm	
Dimensions		
Length max. x width x height max.	1,600 / 930 / 2,110 mm	
Overall weight	495 kg	
Transport packaging flat rate**	TPFR 1	

Accessories	Article no.
Parallel shim set, 20-part	3354001
Copying and facing blade MT 4	3350214
Vibration damper SE1 (4 pcs. required)	3381012
Bore head set MT 4	3352084
Arbor for drill chuck MK4	3350304
Collet chuck MT 4/M16	3352094
Thread tapping chuck M5 - M12	3352042
Height-adjustable tailstock RST 1	3356155
Assortment of clamping tools size 12	3352017
• Metric thread	
Horiz./vert. rotary indexing table RT 150	3356150
End mill set HSS 20-part	3386200
• 10 end mills DIN 327 D version with 2 cutting edges	
• 10 end mills DIN 844 B version with 4 cutting edges	
› More „Accessories for milling machines“ ab Seite 96	

** PTO for an explanation of the packaging surcharges.
*OPTIMUM® is a registered brand of Optimum Maschinen Germany GmbH and exclusively used for milling machines

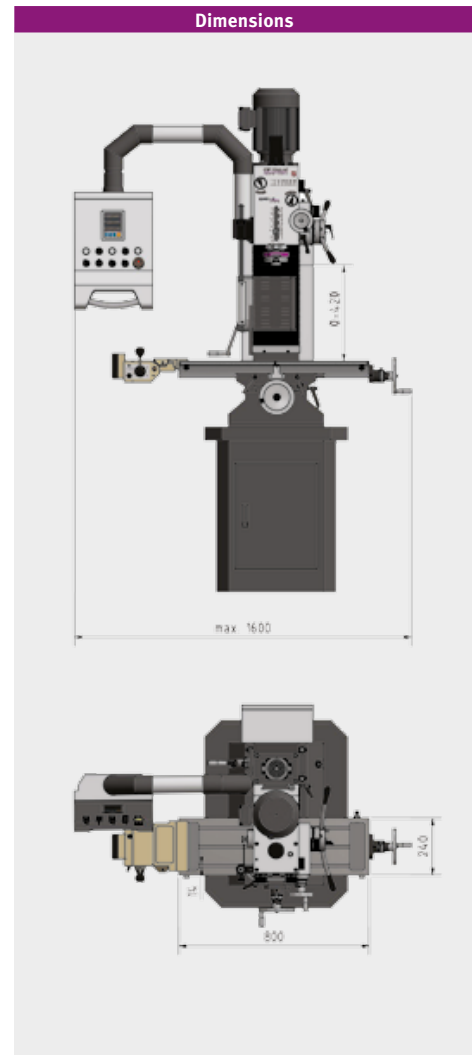

Scope of Delivery

- Machine chassis
- Morse taper MT 3
- Adapter MT 3 - MT 4
- Tightening bar M16
- Operating tool

Vices	Article no.
FMS 100	3354100
FMS 125	3354125
• Guide surfaces tempered and polished	
• Hardened and polished clamping jaws, replaceable	
• With turntable, rotating through 360°	
Rotary indexing tables	
RT 100	3356110
RTE 165	3356365