

Universal precision drilling/milling machine with 2-stage gearbox for optimum power transfer

Facts that impress in terms of quality, performance and price

- ▶ Heavy, solid cast design
- ▶ Smooth action due to polished gearwheels running in an oil sump
- ▶ Large speed range from 95 - 3,200 rpm thanks to 12 switchable speeds
- ▶ Two-stage industrial quality electric motor
- ▶ Clockwise/Anti-clockwise rotation
- ▶ Gear head pivots through $\pm 60^\circ$
- ▶ Adjustable wedge rails
- ▶ Drilling depth stop

"Thread tapping" operating mode

- The motor is activated by moving the spindle sleeve down
- When the preset depth is reached, the spindle reverses
- The machine thread tapping drill moves back out of the workpiece
- When the spindle sleeve has moved in to the switching point, the spindle rotation is stopped

Control panel

- Easy to use
- Emergency stop button
- Selector switch for direction of rotation
- Thread tapping function

Speed change

- Simple via gear selector switch at front

Manual spindle sleeve feed with fine feed

- Handwheel
- Easy to operate

Protective screen

- Height-adjustable
- Generously dimensioned
- Microswitch

Column

- Dovetail guide
- Hand shaved

XY table

- Solid and generously dimensioned
- Precise surface finish
- Adjustable wedge rails
- Adjustable via 3 hand wheels
- Longitudinal scale inset
- Adjustable limit stops

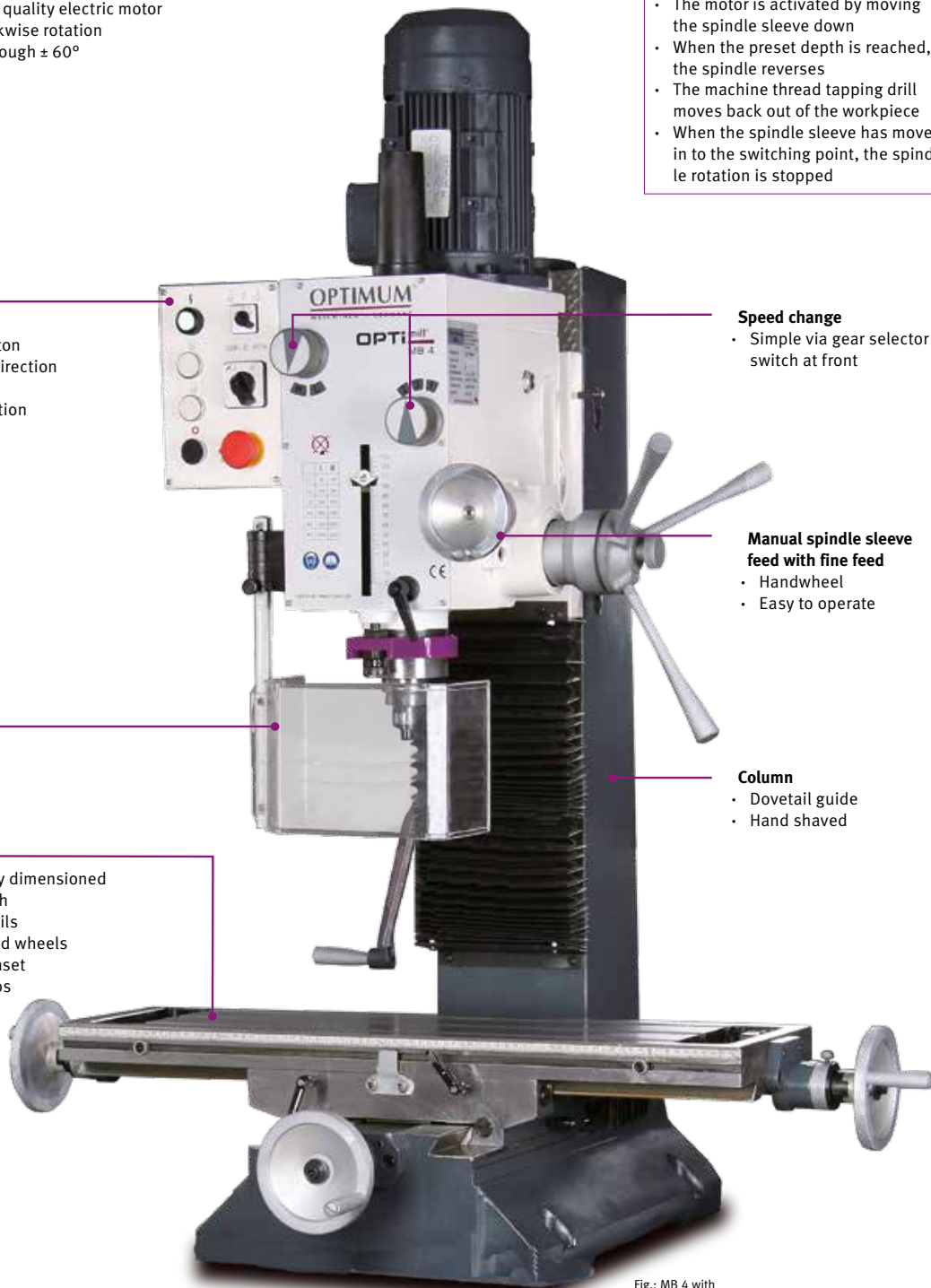

Fig.: MB 4 with optional accessories

Technical specifications, accessories and dimensions

Model	MB 4
Article no.	3338450
Technical data	
Electrical connection	400 V / 3 Ph ~50 Hz
Motor output	1.1 / 1.5 kW
Drilling/milling output	
Drilling performance steel (S235JR)	Ø 32 mm
Continuous drilling performance steel (S235JR)	Ø 28 mm
Max. sensor head size	Ø 63 mm
Max. shaft milling cutter size	Ø 28 mm
Spindle holder	
Spindle sleeve stroke	120 mm
Spindle holder	MT 4
Spindle sleeve diameter	75 mm
Throat	275 mm
Tightening bar	M16
Drilling/milling head	
Swivel range	± 60°
Spindle speeds	95 - 3,200 rpm
Gears	2 x 6 speeds
XY table	
Clearance spindle to XY table max.	460 mm
Table length x width	800 x 240 mm
XY table load bearing capacity	80 kg
T-groove size/amount/spacing	14 mm / 3 / 63 mm
Strokes	
X axis	450 mm
Y axis	195 mm
Z axis	430 mm
Dimensions	
Length x width x height max.	1,100 x 850 x 1,150 mm
Overall weight	320 kg

Scope of Delivery

- Morse taper MT 3
- Adapter MT 3 - MT 4
- Tightening bar M16
- Operating tool

Accessories

Accessories	Article no.
Parallel shim set, 20-part	3354001
Height-adjustable tailstock RST 1	3356155
Horiz./vert. rotary indexing table RT 150	3356150
Assortment of clamping tools size 12	3352017
End mill set HSS 20-part	3386200
• 10 end mills DIN 327 D version with 2 cutting edges	
• 10 end mills DIN 844 B version with 4 cutting edges	
Precision vice FMS 100	3354100
• With turntable	
• Tempered and polished jaws	
Steel chassis	3353006
• Chip tray	
• Dimensions L x W x H: 625 x 415 x 750 mm	
• Weight	54 kg
Universal coolant unit	3352002
• Tank capacity 10 litres	
Vibration damper SE1 (4 pcs. required)	3381012
› More „Accessories for milling machines“ ab Seite 96	

Dimensions

