

## UB 10 - Universal bending machine for angled, round and helical bending of flat and square materials

- ▶ Cold bending up to an angle of 180°
- ▶ Adjustable bending angle stop for a high level of repetition accuracy
- ▶ Also for helical bending with the UB 11 option
- ▶ With bolt-on base for the workshop

- ▶ Easily transportable, ideal for workshop, on site and in the service vehicle
- ▶ Removable bending unit with optional clamping plate can also be deployed on a vice

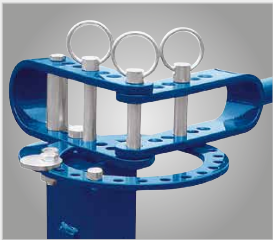

- All hinges tempered
- Tempered bearings
- Bending angle stop



- Angle for bending sharp edges in flat materials
- 4 positioning bolts hold the workpiece

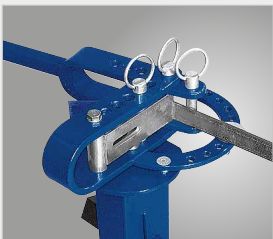

- Application flat materials: acute bending



- Two sets of tempered bending rollers in scope of supply



- plate rolling in flat materials

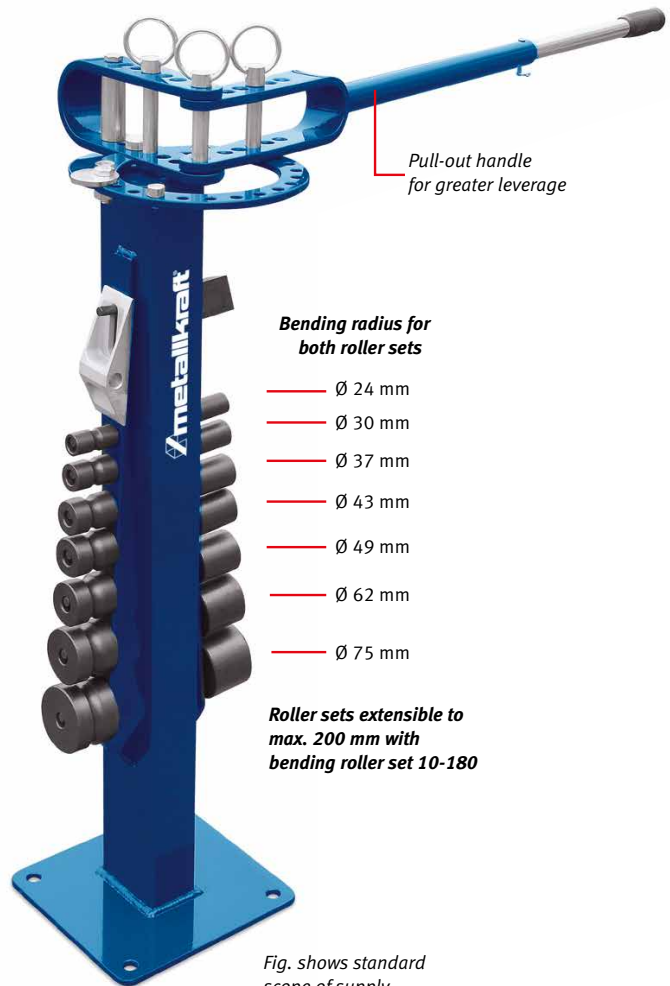
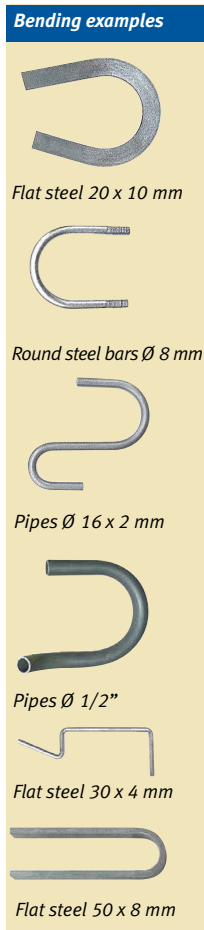

Fig. shows standard scope of supply

<b>Model</b>	<b>UB 10</b>	
Art. no.	3776010	
<b>Technical specifications</b>		
<b>Max. bending dimension</b>		
Flat steel: plate rolling	10 x 50 mm	
Flat steel: acute bending	6 x 50 mm	
Weight	32 kg	
<b>Material</b>	<b>Steel/Aluminium/Copper</b>	<b>Stainless steel</b>
Round materials	Ø 16 mm	Ø 14 mm
Square materials	16 x 16 mm	14 x 14 mm
Pipes	T 3/4"	

\* Bending elements optionally available

**Scope of supply:**

- ▶ Bending rollers: 2 x Ø 24/30/37/43/49/62/75 mm

## Optional accessories UB 10

**Model** Art. no.  
**Heating pipe bending roller set** 3790001

- ▶ For cold bending of heating pipes of sizes G3/8", G1/2", G3/4".
- ▶ Set consists of 2 items per size. Weight 15 kg

**Inner diameter for bend**

- ▶ G 3/8" 102 mm
- ▶ G 1/2" 108 mm
- ▶ G 3/4" 112 mm

▶ *Grey cast iron*

▶ *Galvanised steel*

**Bending rollers specially for pipes**



**Bending roller set 10-180** 3790002

- ▶ For bending strip steel up to 50 mm width and 7 mm thickness and square materials up to 16 x 16 mm
- ▶ Ideal for smithing work
- ▶ Set consists of 8 bending rollers
- ▶ Extends the bending capacity to Ø 110, 150, 175, 200 mm
- ▶ Weight 33 kg



**Adjustable stop 10-200** 3790003

- ▶ Universal, adjustable stop
- ▶ for small batch work



**Clamping plate** 3790004

- ▶ For mounting the non-mounted bending unit of the UB 10 on a commercially available vice
- ▶ As a simple solution on site, without needing to dismount the base of the UB 10 and take it with you
- ▶ Also usable for RB 30
- ▶ Weight 1.5 kg
- ▶ Supplied without vice



**Conversion kit for UB 10 to RB 30** 3790006

- ▶ For bending thin-walled pipes
- ▶ With bending elements, angle element and guides
- ▶ Installation through replacing the bending elements
- ▶ Bending elements 6 pcs. : Ø 14, 16, 18, 20, 22, 25 mm
- ▶ Weight 31 kg



Accessories/bending segments from page 85 usable

## Helical bending element UB 11

- ▶ Add-on part for helical bending on the UB 10
- ▶ For helical bending
- ▶ Small helix can be used independently
- ▶ Supporting roller
- ▶ Easily attachable large bending segment

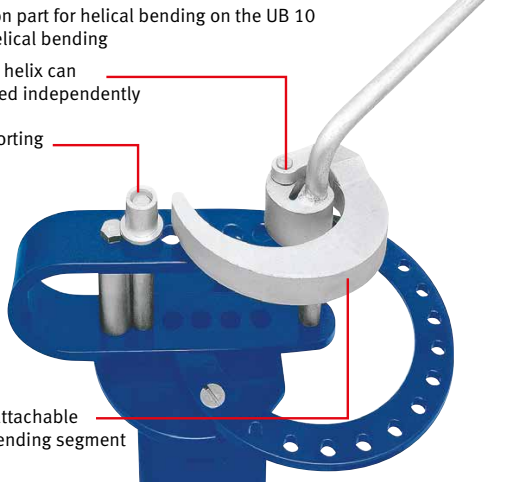

**Bending examples**



Model	Helical bending element UB 11
Art. no.	3790011

Technical specifications	
Max. material thicknesses	
Square	5 x 5 mm
Flat materials	5 x 25 mm
Round materials	Ø 5 mm
Weight	3 kg

*Separate holding handle for helical bending element UB 11 allows operation of the UB 11 without the UB 10 on a commercially available vice*

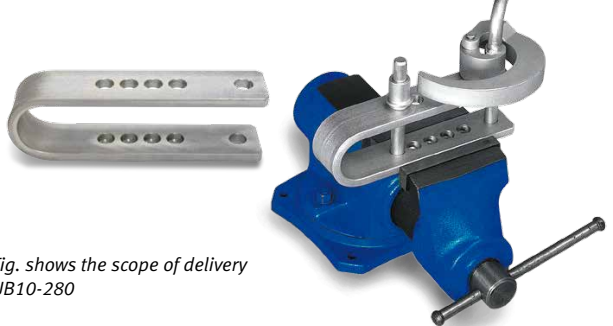

Fig. shows the scope of delivery UB10-280

Model	UB 10-280
Art. no.	3790280