

WB 100 - Angle bender for enthusiasts and trade professionals

- ▶ For precise cold and hot bending of flat, round and square steel
- ▶ Robust design for bolting onto the workbench
- ▶ Drill holes in cast bed for fastening to the workbench
- ▶ Infinitely adjustable bending stop
- ▶ With eccentric quick release for a rational style of work
- ▶ Bending angles up to 120°
- ▶ High level of repetition accuracy due to bending angle stop
- ▶ Ideal for repair workshops and smithies
- ▶ Particularly rugged design

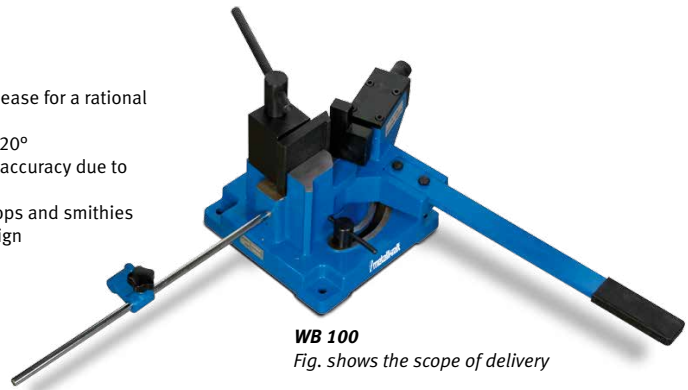

Model	WB 100
Art. no.	3776101

Technical specifications	
<i>Cold:</i>	
Flat steel	100 x 8 mm
Round steel bars	22 mm
Square steel bars	20 x 20 mm
<i>Hot:</i>	
Flat steel	100 x 15 mm
Round steel bars	27 mm
Square steel bars	25 x 25 mm
Dimensions in mm	550 x 320 x 240 mm
Weight	30 kg

Scope of supply:

- ▶ Angle stop
- ▶ Bending plate
- ▶ Bending lever
- ▶ Material stop

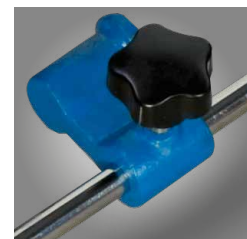

HRB 10 - Hydraulic pipe bender for universal application range with 6 bending segments from 1/2" - 2"

- ▶ Bending range 1/2" - 2"
- ▶ Incl. 6 bending segments (1/2" - 3/4" - 1" - 1 1/4" - 1 1/2" - 2")
- ▶ With fold-up bending frame for convenient and rational operation
- ▶ Universally deployable for heating, gas, boiler and water pipes, cooper tube and composite pipes
- ▶ 10 t pressure output
- ▶ With tripod stand for an ergonomic approach



Model	HRB 10
Art. no.	3777010
Technical specifications	
Pressure output	10 t
Bending forms	1/2" - 3/4" - 1" - 1 1/4" - 1 1/2" - 2"
Number of legs	3
Piston stroke	155 mm
Dimensions	710 x 590 x 220 mm
Weight	45 kg

Bending segment	Pipe radius	Wall thickness	Bending radius	Bending angle	Art. no.
1/2"	21.3 mm	3.25 mm	62 mm	0-90 °	3777011
3/4"	26.9 mm	3.50 mm	78 mm	0-90 °	3777012
1"	33.7 mm	4.00 mm	98 mm	0-90 °	3777013
1 1/4"	42.4 mm	4.00 mm	128 mm	0-120 °	3777014
1 1/2"	48.3 mm	4.25 mm	148 mm	0-120 °	3777015
2"	60.3 mm	4.50 mm	187 mm	0-120 °	3777016