

Fodbetjente værkstedspresser 16 - 25 tons



Søgeord:
 Compac FP 25



FP 20
 FP 25

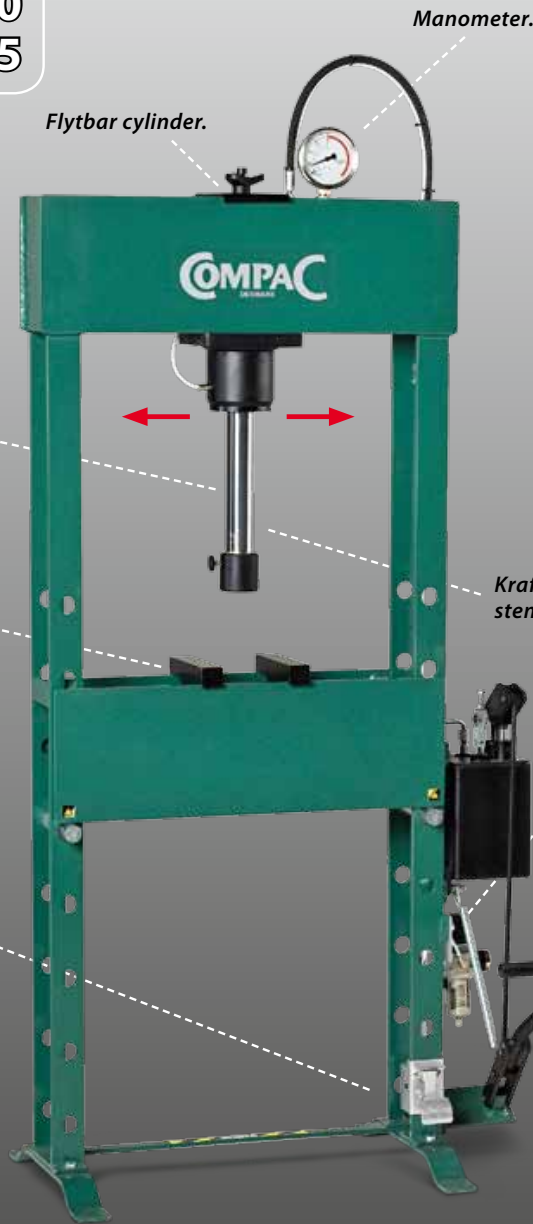

Tilbehør

61240



Hyldesystem til opbevaring af tilbehør.

Kr. 399,-

Lang slaglængde på 240 mm. (FP20 / FP25).

To rettelokke.



Hurtig, fodbetjent trykluftstyret fremføring af stempel. (FP20 / FP25)

Kraftigt, hårdtforkromet stempel.

Lufttilslutning monteret med vandudskiller. (FP20 / FP25)

Trykluftstyret returneringsfunktion er indbygget i fodbetjening. (FP20 / FP25)

Fodbetjening sikrer "handsfree" betjening under belastning.

Model	Max (Ton)	(mm/stroke)	A (mm)	B (mm)	C (mm)	D (mm)	E (mm)	F (mm)	G (mm)	H (mm)	I (mm)	Kg	Kr.
FP 16	16	6,0/2,0	1200	550	140	150	65	40	1780	850	600	125	7.790,-
FP 20	20	9,0/1,1	825	600	140	240	90	70	1800	890	505	154	8.390,-
HP 20	20	9,0/4,0	825	600	140	240	90	70	1800	890	505	154	8.390,-
FP 25	25	9,0/1,1	825	600	140	240	90	70	1800	890	505	154	9.990,-
HP 25	25	9,0/4,0	825	600	140	240	90	70	1800	890	505	154	9.990,-

Håndbetjente værkstedspresser 20 - 25 tons

HP 20
HP 25

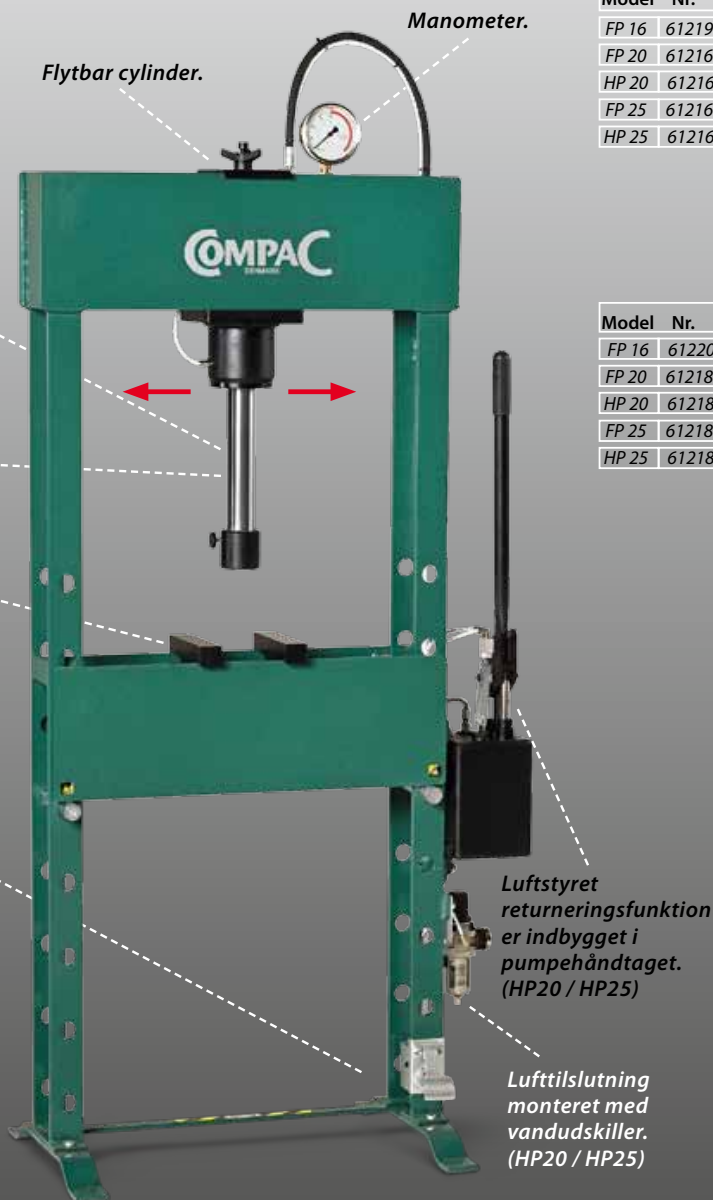

Model	Nr.
FP 16	61219
FP 20	61216
HP 20	61216
FP 25	61216
HP 25	61216

Model	Nr.
FP 16	61220
FP 20	61218
HP 20	61218
FP 25	61218
HP 25	61218

Tilbehør



Dornsæt.
(7 stk. Ø12, 16, 18, 20, 22, 25, 30)
Kr. 699,-



Lejudpresnings sæt.
(4 stk. Ø64, 67, 72, 75)
Kr. 899,-

61100



Presseplade.
Kr. 399,-

52010



Fabrikmonteret spil til FP20/HP20/FP25/HP25
+ Kr. 1.990,-

61242



Beskyttelsesskærm.
Kr. 2.190,-



Hurtig, fodbetjent trykluftstyret fremføring af stempel. (HP20 / HP25)

