

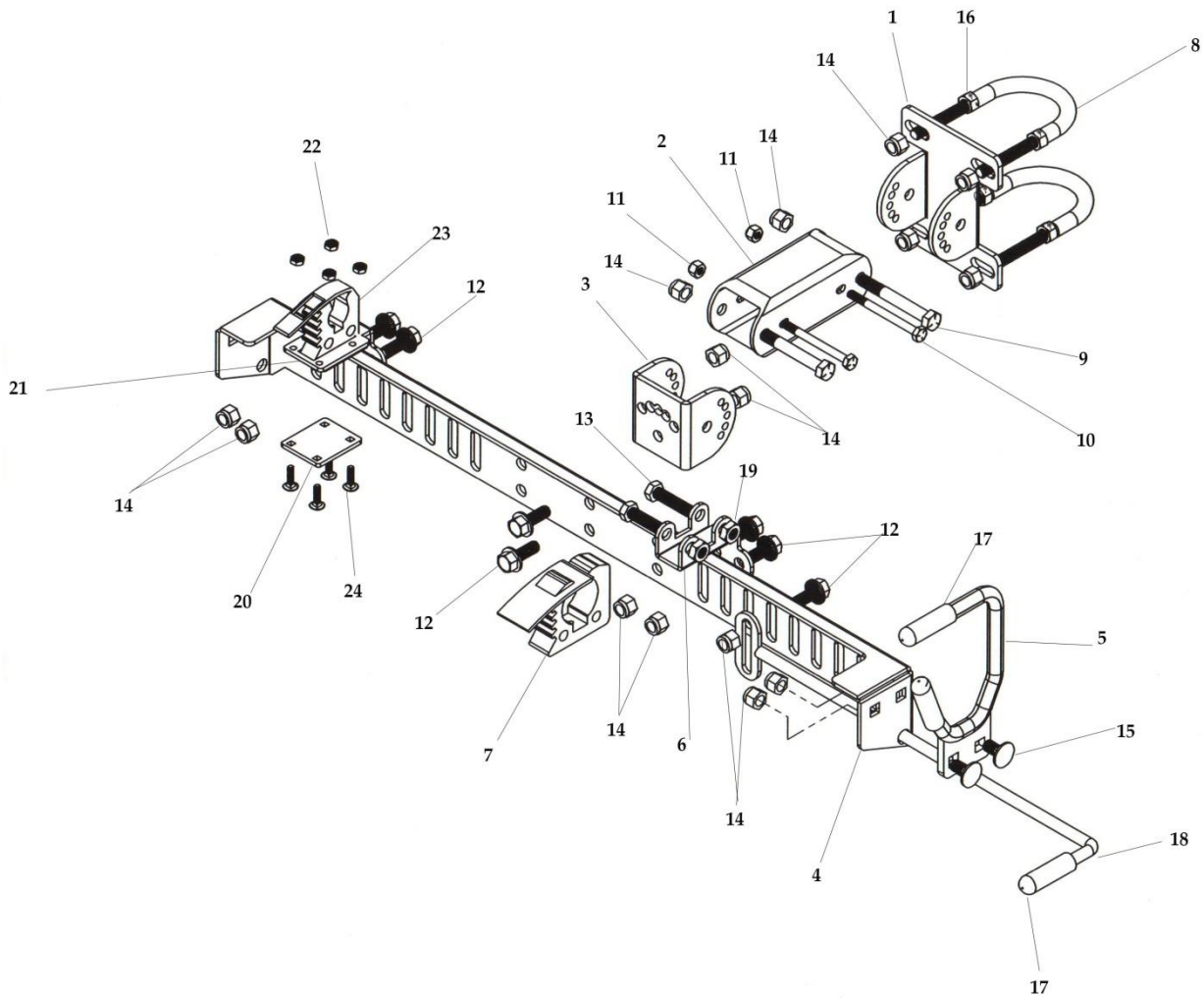

**ZTR-TR
ASSEMBLY
INSTRUCTIONS**

ITEM #	PART #	Description	Qty.
1	ZT-001	Adjustment Bracket	1
2	ZT-002	Adjustment Tube	1
3	ZT-003	Swivel Bracket	1
4	ZT-005	Main Support	1
5	ZT-009	Support Bracket	1
6	ZT-007	Clamp Holder	1
7	741	Large Quick Clamp	1
8	738	3/8" – 16 U-Bolt	2
9	248	3/8" - 16 x 3" Cap Screw	2
10	250	1/4" - 20 x 3" Cap Screw	2
11	331	1/4" - 20 Nylon Locknut	2
12	253	3/8" – 16 X 1" Serrated Hex Head Screw	7
13	124	5/16" – 16 x 1 3/4" Hex Head Cap Screw	2
14	302	3/8" - 16 Nylon Lock Nut	15
15	104	3/8" – 16 x 3/4" Carriage Bolt	2
16	330	3/8" x 16 Hex Nut	4
17	Vinyl – 2.38	3/8" X 2" vinyl sleeve	3
18	ZT-010	Engine Support	1
19	333	5/16" – 16 Hex Nut	2
20	ZT-014	Clamp Holder Bottom	1
21	ZT-013	Clamp Holder Top	1
22	334	10-24 Nylon Lock Nut	4
23	752	Small Quick Clamp	1
24	126	10-24 x 3/4" Carriage Bolt	4



ASSEMBLY

1. Attach the Adjustment Bracket (1) to the Adjustment Tube (2) using one 3/8" – 16 x 3" cap screw (9) and one 3/8" – 16 nylon lock nut (14) in the large hole in the middle of the bracket tabs. To adjust the angle of the tube, use one 1/4" – 20 x 3" cap screw (10) and one 1/4" – 20 nylon lock nut (11) in one of the five smaller holes.
2. Attach the Main Support (4) to the Swivel Bracket (3) using two 3/8" – 16 x 1" serrated hex head screws (12) and two 3/8" – 16 nylon locknuts (14).
3. Attach the Adjustment Tube (2) to the Swivel Bracket (3) using one 3/8" – 16 x 3" Cap screw (9) and one 3/8" – 16 nylon lock nut (14) in the large hole in the middle of the bracket tabs. To adjust the angle of the tube, use one 1/4" – 20 x 3" Cap screw (10) and one 1/4" – 20 nylon lock nut (11) in one of the five smaller holes.
4. The support bracket (5) should be mounted on the end that you will be placing the trimmer engine, using two 3/8 – 16 x 1.5" carriage bolts (15) and two 3/8" – nylon lock nuts (14).
5. Slide the two 2" vinyl sleeves (17) on the top and bottom ends of the support bracket (5).
6. Attach the Large quick clamp (7) onto clamp holder (6) using two 5/16" – 16 x 1.75" hex head cap screws (13) and two 5/16" - 16 Hex Nuts (19).

7. Assemble the Small Quick Clamp (23), by taking the Clamp Holder Top (21) over the Small Quick Clamp (23). Insert the Strap end first then turn the Clamp Top 90 degrees clockwise and push the front of the Small Quick Clamp through the Quick Clamp top.
8. Attach Clamp Holder Bottom (20) to the Clamp Holder Top (21) using four 10-24 x 3/4" Carriage Bolts (24) and four 10-24 Nylon Lock Nuts (22).
9. Attach each clamp holders on the main support (4) using two 3/8" – 16 serrated hex head screws (12) and two 3/8" – 16 nylon locknuts (14) each.
10. Prior to mounting the adjustment bracket (1) to the mower ROPS, screw two 3/8" – 16 hex nuts (16) onto each u-bolt (8).
11. Select desired location on your roll bar. Attach the assembled unit onto the roll bar by sliding each u-bolt (8) and fastening in place using two 3/8" – 16 nylon lock nuts (14) so that the adjustment bracket is locked between the two nuts.
12. Adjust tightness of u-bolts on the roll bar by adjusting the lock nuts.
13. To adjust angle of the ZTR-TR, loosen top bolt (12) on the main support/swivel bracket connection and remove the bottom bolt (12). Then adjust main support to desired angle. Once best angle is found, replace bottom bolt in the aligned hole and tighten all nuts. (see image below)

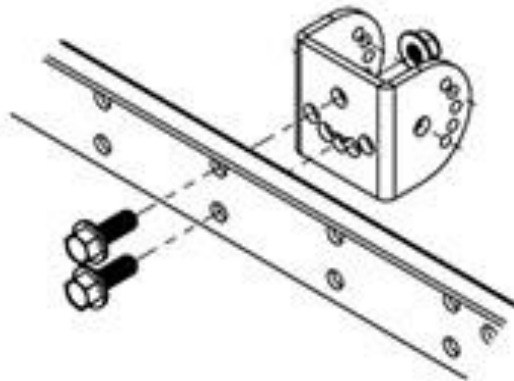

14. OPTIONAL ENGINE SUPPORT. Attach the optional engine support (18) by inserting the support from the inside end of the main support (4) using a 3/8" – 16 x 1" serrated hex head screw (12) and a 3/8" – 16 nylon locknut (14). Support may be adjust according to trimmer length. Attach vinyl (17).
15. If you wish to lock the ZTR-TR, Jungle Jim's recommends using a flexible gun lock which will mount through a hole of the main support and around the trimmer.

****Roll bars greater than 2" will require a larger u-bolt (which can be purchased at your local hardware store).**