

Ecoustic® Torque Ceiling

—
A highly functional acoustic modular ceiling tile
that is easy to install

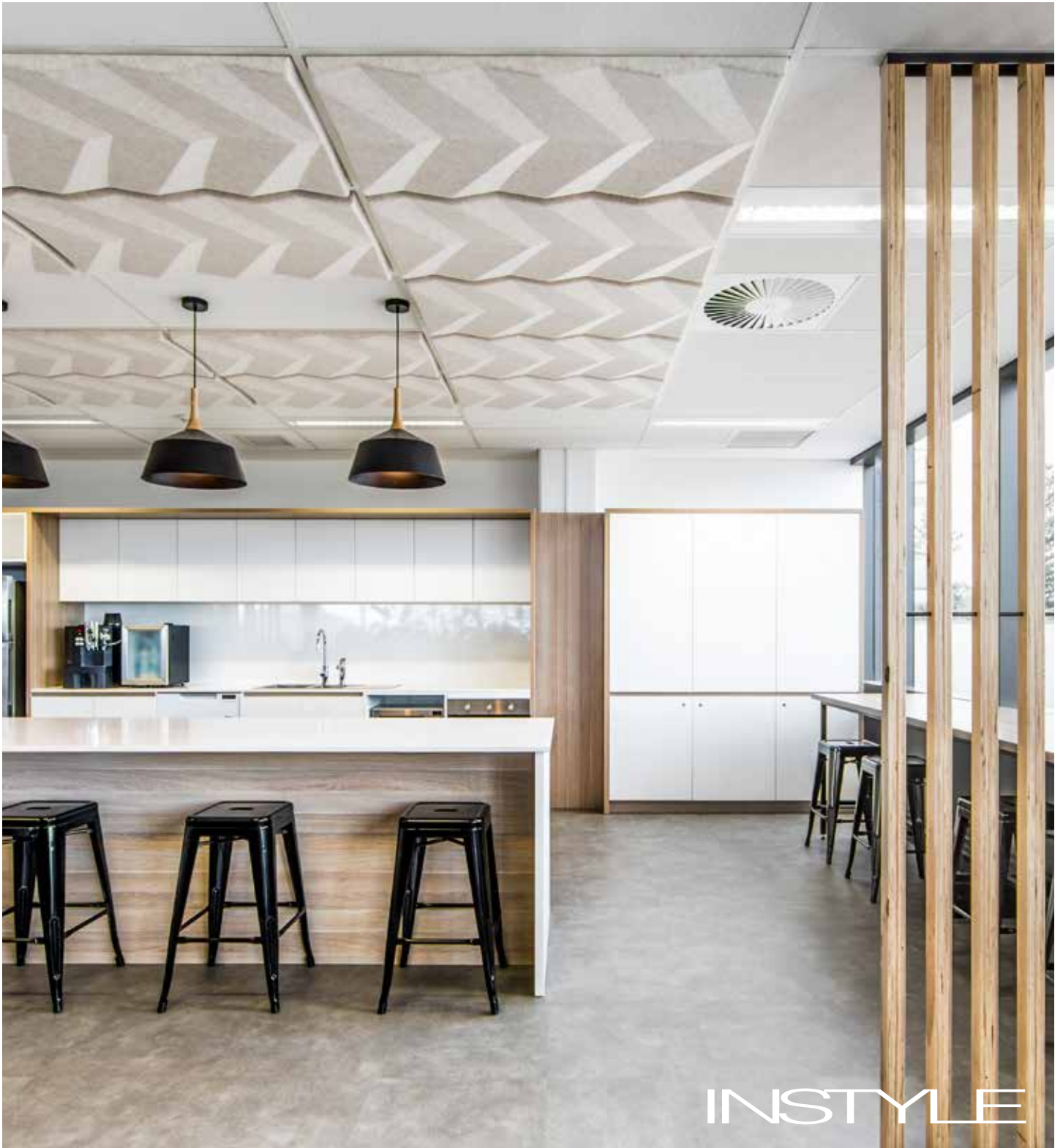

Ecoustic® Torque Ceiling Tile

Front View
600 Tile: 595 x 595mm

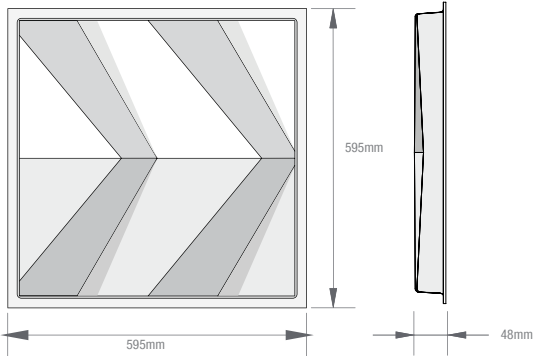

Side View

Front View
1200 Tile: 1195 x 595mm

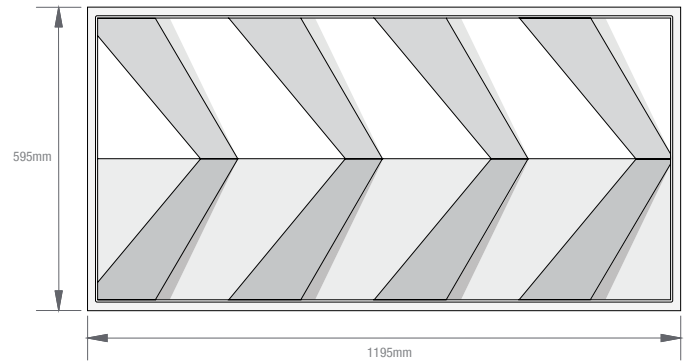

PRODUCT

Ecoustic® Torque Ceiling Tile

DESCRIPTION

Ecoustic® Torque is an acoustic modular ceiling tile that provides outstanding low and mid range frequency performance

DIMENSIONS

600 Tile: 595mm (w) x 595mm (h) x 48mm (d)
1200 Tile: 1195mm (w) x 595mm (h) x 48mm (d)
Torque Ceiling Tile drops into new or existing 15mm and 24mm Exposed Tee drop ceiling grid systems with a nominal 600 x 600mm or 1200 x 600mm grid. Ensure the tile is suitable for your selected system prior to ordering

ACOUSTIC

α_w 0.8 / NRC 0.8 (400mm air cavity)

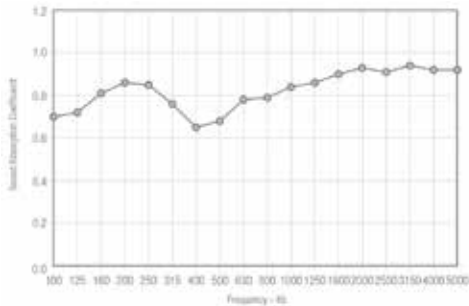

FIRE TEST

AS/ISO 9705

Group 1
SMOGRA <100

GB8624-2012

Grade B1

APPLICATION

ceiling tiles

ORIGIN

Made in Australia

Please contact your representative for CAD drawings

BENEFITS

Designed for the Environment

- Based on low energy manufacturing
- 100% polyester (up to 80% PC + PI recycled content)
- Designed for disassembly + recyclable
- Low-VOC, EPD + Greentag Level A Certified

Toxicity: Polyester is non-toxic and is classed the same as wood under the State of New York Article 15 Part 1120. Torque Ceiling Tile does not contain any Red List Chemicals (USA EPA).

Warranty: A 12 month warranty is provided against manufacturing defects. Internal installation only, outdoor use will void any warranty.

Building Rating Systems: Torque will contribute the following points for Green Star, LEED + WELL building standards.

Criteria	Green Star	LEED	WELL
Recycled Content	✓	✓	NA
Low VOC	✓	✓	✓
Recycling Program	✓	✓	NA
EPD	✓	✓	NA
Third Party Greentag Level A Certification	✓	✓	✓
Toxic Material Reduction	NA	NA	✓
Sound Reducing Surfaces	NA	NA	✓

HOW TO SPECIFY

DESIGN	Ecoustic® Torque Ceiling Tile
TILE SIZE	600 Tile or 1200 Tile
COLOUR	Select from Ecoustic® Felt colours

Ecoustic® Torque Ceiling Tile Components

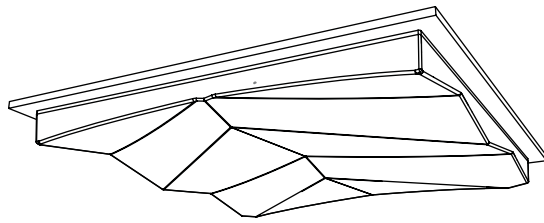

Ecoustic® Torque Ceiling Tile
100% polyester (up to 80% recycled content)
8 tiles per box in a single colour

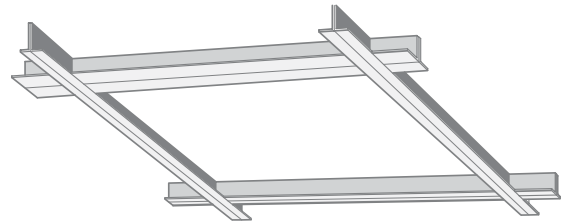

Drop Ceiling Frame
15mm + 24mm Exposed Tee grid system
[Not supplied]



IMPORTANT

Moisture Absorption: Exposure to an atmosphere of 50% and 95% RH for four days provides moisture absorption of less than 0.2% per volume. As Torque Ceiling tile is 100% polyester, it will not degrade over time due to moisture, mildew or rot in office environments.

Fixtures: Fixtures must be supported independent to the ceiling tile. Torque can be cut on site to accommodate for new and existing lighting and fixtures. When cutting, use a new blade for each cut and ensure the cutting area is fully supported throughout. Cut from the tile face with care.

HVAC: Ensure Torque Ceiling Tile is compliant with the specified HVAC system. Torque Ceiling Tile is recommended for Ducted Return Air and is not Plenum Return Air rated.

Back Loading: Torque Ceiling Tile is not suitable for back loading. Loads must be supported independently by the grid or through the use of additional fixtures.

Product may vary in colour due to the nature of the media
Please refer to website for current colour range

Variation in fibre mix and colour is an inherent feature of this product and variation from batch to batch may occur

INSTYLE