

# PACK CONTENTS

- 1 x Lattice baffle
- 4 x 1m galvanised cables
- 4 x ceiling mounts
- 4 x "Velda" cable clips
- 4 x alloy tube inserts

# CONSTRUCTING THE LATTICE

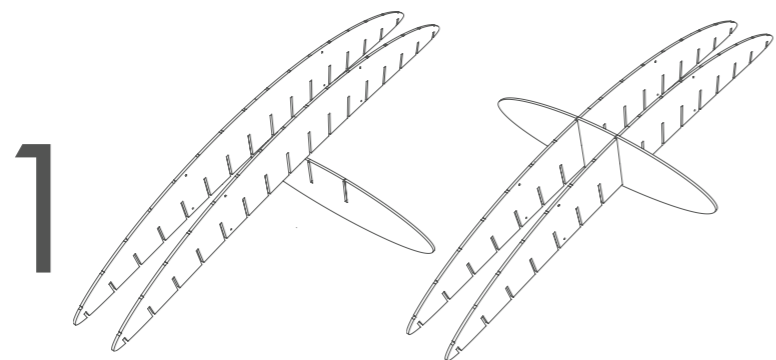

Sort the Lattice 'fins' into pairs, then into size order: largest to smallest. Start by taking one of the largest fins and slotting it into place in the 'rail'.

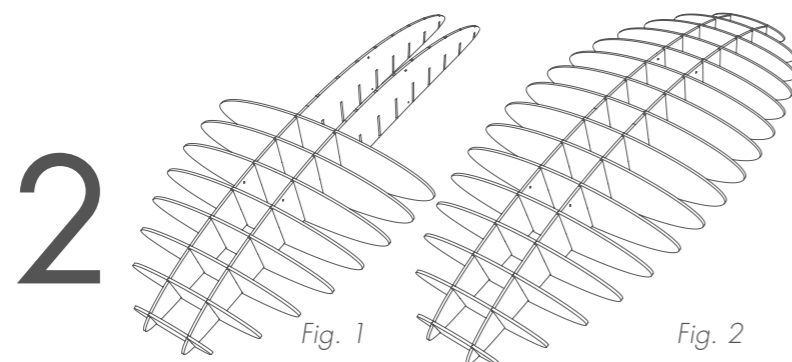

Finish one side by methodically inserting one of each pair into place in order of decreasing size (Fig. 1). Repeat for the other side (Fig. 2).

# HANGING THE LATTICE

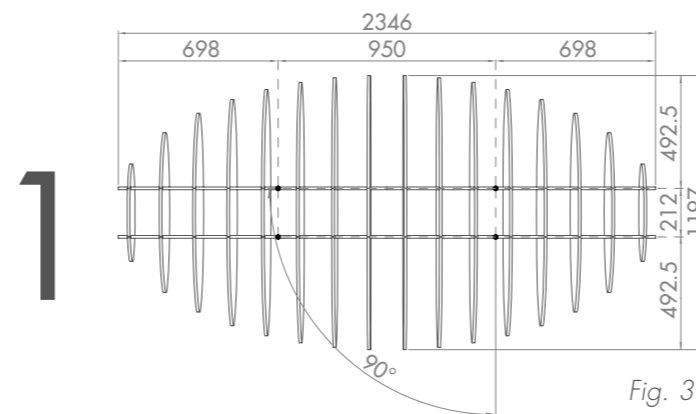

Determine where you want the Lattice to hang (Fig. 3). Mark the ceiling mount points as per the dotted lines.

Remove the round plugs in the pre-cut holes of each Lattice rail and replace with the supplied alloy tube inserts (Fig. 4).

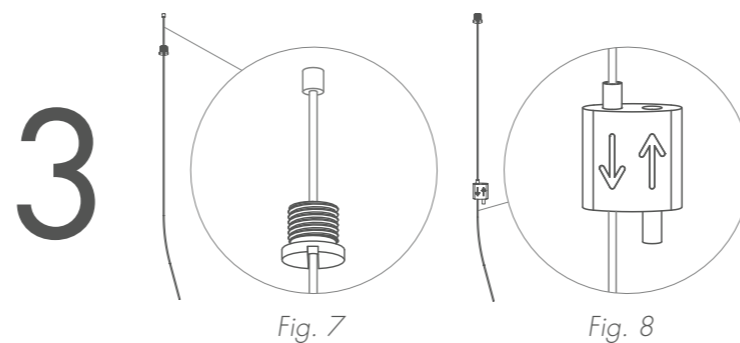

Thread the ceiling mount caps (Fig. 6) onto the cables (Fig. 7).

Thread the "Velda" cable clips onto cables (Fig. 8).

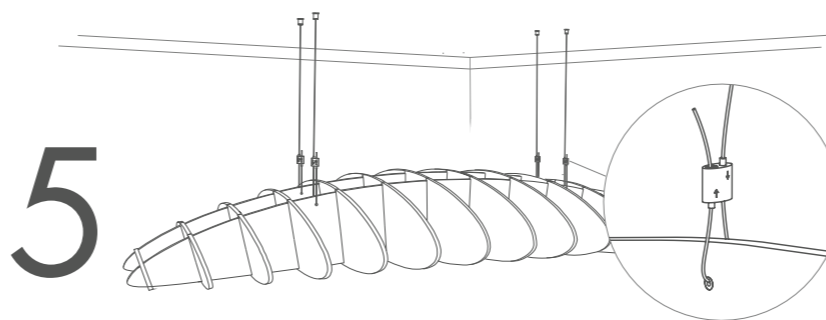

Lift the Lattice up to meet the cables and loop the wires through the plugs followed by the "Velda" cable clips.

When the Lattice is hung, use the toggles to make minor adjustments to set correct, level height\*. Once set, trim excess wire, leaving 30mm for seismic compliance.

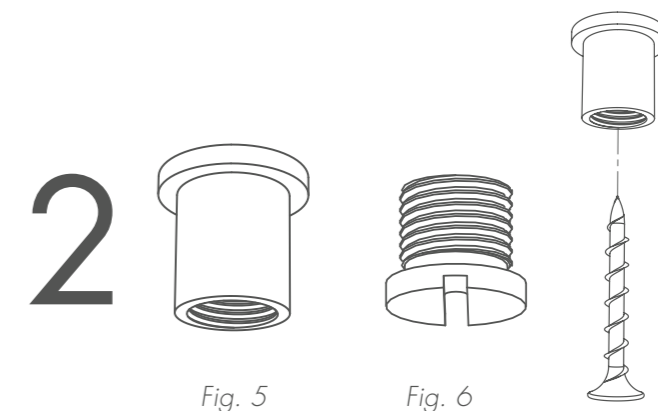

Separate the ceiling mounts into their individual parts - ceiling mounts (Fig. 5) and ceiling mount caps (Fig. 6).

Screw ceiling mounts (Fig. 5) to the ceiling substrate at the marked centres (Step 1) with a fixing appropriate for the substrate.

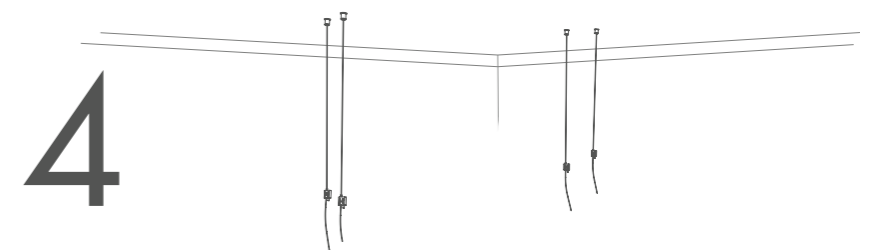

Screw assembled cables into the fixed ceiling mounts.

Decide which way up the Lattice will hang - convex down or convex up - and lay the rails out in their correct orientation.

\*SPEAK TO YOUR ACCOUNT MANAGER FOR MORE INFORMATION ON SETTING THE BEST SUSPENSION HEIGHT FOR YOUR APPLICATION.

Quiespace®  
**LATTICE**  
eclipse