

1×5" BELT DISC SANDER

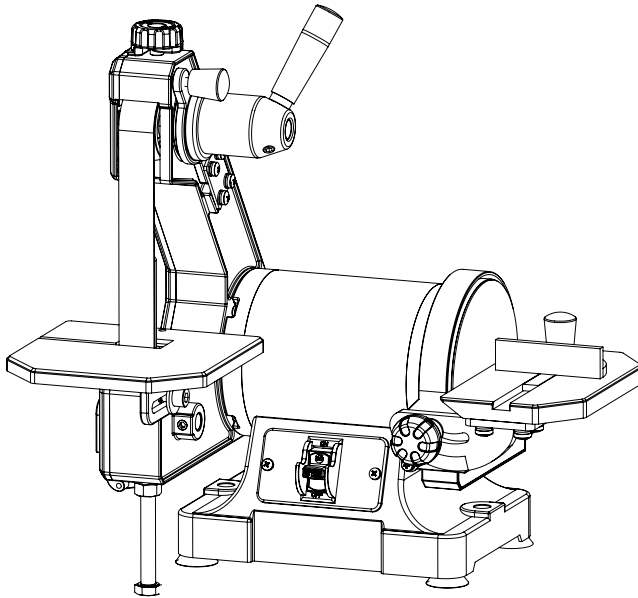

Instagram

Contact Us:

email: service@bucktool.com

<https://www.bucktool.com>

IMPORTANT:

For your own safety, read and follow all of the Safety Guidelines and Operating Instructions before operating this product.

**INSTRUCTION
MANUAL**

TABLE OF CONTENTS

Specifications	2
Safety guidelines	3
Package contents	8
Operating instructions	9
Maintenance	12
Troubleshooting	13
Exploded view	14
Parts list	15
Warranty	16

SPECIFICATIONS

Motor	120VAC, 60Hz , 2.3A
Speed (no load)	3590RPM
Belt size	1" x 30"
Belt speed	3300 FPM
Disc size	5"
Disc speed	3590RPM

SAFETY GUIDELINES - DEFINITIONS

- Always wear safety goggles or safety glasses with side shields.
- Always wear respiratory and hearing protection.
- To reduce the risk of injury, user and all bystanders must read and understand instruction manual before using this product.
- Failure to keep your hands away from the moving part and cutting surface will result in serious personal injury.
- No children or pregnant women should enter the work area where the paint sanding is being done until all clean up is completed.
- A dust mask or respirator should be worn by all persons entering the work area. The filter should be replaced daily or whenever the wearer has difficulty breathing.
- NO EATING, DRINKING or SMOKING should be done in the work area to prevent ingesting contaminated paint particles. Workers should wash and clean up BEFORE eating, drinking or smoking. Articles of food, drink, or smoking should not be left in the work area where dust would settle on them.
- Paint should be removed in such a manner as to minimize the amount of dust generated.
- Areas where paint removal is occurring should be sealed with plastic sheeting of 4 mil thickness.
- Sanding should be done in a manner to reduce tracking of paint dust outside the work area.
- All surfaces in the work area should be vacuumed and thoroughly cleaned daily for the duration of the sanding project. Vacuum filter bags should be changed frequently.
- Plastic drop cloths should be gathered up and disposed of along with any dust chips or other removal debris. They should be placed in sealed refuse receptacles and disposed of through regular trash pick-up procedures. During clean up, children and pregnant women should be kept away from the immediate work area.
- All toys, washable furniture and utensils used by children should be washed thoroughly before being used again.

WARNING!

Use of this tool can generate and/or disperse dust, which may cause serious and permanent respiratory or other injury. Always use NIOSH/OSHA approved respiratory protection appropriate for the dust exposure. Direct particles away from face and body.

POWER TOOL SAFETY

1. READ and become familiar with the entire Instruction Manual. LEARN the tool's application, limitations and possible hazards.
2. KEEP GUARDS IN PLACE and in working order.
3. REMOVE ADJUSTING KEYS AND WRENCHES. Form the habit of checking

- to see that keys and adjusting wrenches are removed from the tool before turning ON.
4. **KEEP WORK AREA CLEAN.** Cluttered areas and benches invite accidents.
 5. **DO NOT USE IN DANGEROUS ENVIRONMENTS.** Do not use power tools in damp locations, or expose them to rain or snow. Keep work area well lit.
 6. **KEEP CHILDREN AWAY.** All visitors and bystanders should be kept a safe distance from work area.
 7. **MAKE WORKSHOP CHILD PROOF** with padlocks, master switches or by removing starter keys.
 8. **DO NOT FORCE THE TOOL.** It will do the job better and safer at the rate for which it was designed.
 9. **USE THE RIGHT TOOL.** Do not force the tool or an attachment to do a job for which it was not designed.
 10. **USE PROPER EXTENSION CORDS.** Make sure your extension cord is in good condition. When using an extension cord, be sure to use one heavy enough to carry the current your product will draw. An undersized cord will result in a drop in line voltage and in loss of power which will cause the tool to overheat. The table on page 8 shows the correct size to use depending on cord length and nameplate ampere rating. If in doubt, use the next heavier gauge. The smaller the gauge number, the heavier the cord.
 11. **WEAR PROPER APPAREL.** Do not wear loose clothing, gloves, neckties, rings, bracelets or other jewelry which may get caught in moving parts. Nonslip footwear is recommended. Wear protective hair covering to contain long hair.
 12. **ALWAYS WEAR EYE PROTECTION.** Any power tool can throw foreign objects into the eyes and could cause permanent eye damage. **ALWAYS** wear Safety Goggles (not glasses) that comply with ANSI Safety standard Z87.1. Everyday eyeglasses have only impact-resistant lenses. They **ARE NOT** safety glasses. **NOTE:** Glasses or goggles not in compliance with ANSI Z87.1 could seriously injure you when they break.
 13. **WEAR A FACE MASK OR DUST MASK.** Sanding operation produces dust.
 14. **SECURE WORK.** Use clamps or a vise to hold work when practical. It is safer than using your hand and it frees both hands to operate the tool.
 15. **DISCONNECT TOOLS FROM POWER SOURCE** before servicing, and when changing accessories such as blades, bits and cutters.
 16. **REDUCE THE RISK OF UNINTENTIONAL STARTING.** Make sure switch is in the OFF position before plugging the tool in.
 17. **USE RECOMMENDED ACCESSORIES.** Consult this Instruction Manual for recommended accessories. The use of improper accessories may cause risk of injury to yourself or others.
 18. **NEVER STAND ON THE TOOL.** Serious injury could occur if the tool is tipped or if the cutting tool is unintentionally contacted.
 19. **CHECK FOR DAMAGED PARTS.** Before further use of the tool, a guard or

other part that is damaged should be carefully checked to determine that it will operate properly and perform its intended function – check for alignment of moving parts, binding of moving parts, breakage of parts, mounting and any other conditions that may affect its operation. A guard or other part that is damaged should be properly repaired or replaced.

20. NEVER LEAVE THE TOOL RUNNING UNATTENDED. TURN THE POWER “OFF”. Do not walk away from a running tool until the blade comes to a complete stop and the tool is unplugged from the power source.
21. DO NOT OVERREACH. Keep proper footing and balance at all times.
22. MAINTAIN TOOLS WITH CARE. Keep tools sharp and clean for best and safest performance. Follow instructions for lubricating and changing accessories.
23. DO NOT use power tool in presence of flammable liquids or gases.
24. DO NOT operate the tool if you are under the influence of any drugs, alcohol or medication that could affect your ability to use the tool properly.
25. Dust generated from certain materials can be hazardous to your health. Always operate saw in well-ventilated area and provide for proper dust removal.
26. WEAR HEARING PROTECTION to reduce the risk of induced hearing loss.

WARNING!

People with electronic devices, such as pacemakers, should consult their physician(s) before using this product. Operation of electrical equipment in close proximity to a heart pacemaker could cause interference or failure of the pacemaker.

POWER TOOL SAFETY

1. USE sander on horizontal surfaces only. Operating the sander when mounted on non-horizontal surfaces might result in motor damage.
2. TO STOP it from tipping over or moving when in use, the sander must be securely fastened to a bench top or supporting surface.
3. PLACE the sander so neither the user nor bystanders are forced to stand in line with the abrasive belt or disc.
4. MAKE SURE the sanding belt is installed in the correct direction. See directional arrow on back of belt.
5. ALWAYS have the tracking adjusted properly so the belt does not run off the pulleys.
6. DO NOT USE sanding belts or discs that are damaged, torn or loose. Use only correct size sanding belt and disc. Narrower belts uncover parts that could trap fingers.
7. MAKE SURE there are no nails or foreign objects in the part of the workpiece to be sanded.
8. ALWAYS HOLD the workpiece firmly when sanding. Keep hands away from sanding belt or disc. Sand only one workpiece at a time.

9. ALWAYS HOLD the workpiece firmly on the table when using the disc sander and when using the belt sander.
10. ALWAYS SAND ON THE DOWNWARD SIDE of the sanding disc when using the disc sander. Sanding on the upward side of the disc could cause the workpiece to fly out of position, resulting in injury.
11. ALWAYS maintain a minimum clearance of 1/16 in. (1.6 mm) or less between the table or backstop and the sanding belt or disc.
12. DO NOT sand pieces of material that are too small to be safely supported.
13. KEEP fingers away from where the belt goes into the dust trap.
14. WHEN sanding a large workpiece, provide additional support at table height.

IMPORTANT INFORMATION-Electrical

A separate electrical circuit should be used for your machines. This circuit should not be less than #12 wire and should be protected with a 20-A time-lag fuse. If an extension cord is used, use only 3-wire extension cords which have 3-pronged grounding type plugs and matching receptacle which will accept the machine's plug. Before connecting the machine to the power line, make sure the switch is in the "OFF" position and be sure that the electric current is of the same characteristics as indicated on the machine. All line connections should make good contact. Running on low voltage will damage the machine.

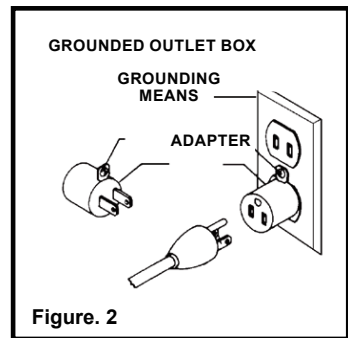
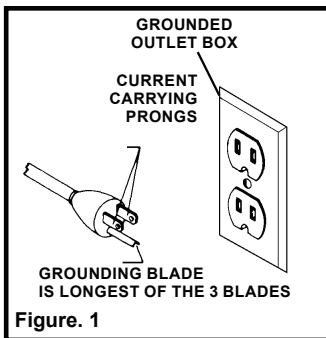

MOTOR SPECIFICATIONS

Your machine is wired for 120 V, 60Hz alternating current. Before connecting the machine to the power source, make sure the switch is in the "OFF" position.

GROUNDING INSTRUCTIONS

All grounded, cord-connected machines: In the event of a malfunction or breakdown, grounding provides a path of least resistance for electric current to reduce the risk of electric shock. This machine is equipped with an electric cord having an equipment grounding conductor and a grounding plug.

NOTE: THIS MACHINE MUST BE GROUNDED WHILE IN USE TO PROTECT THE OPERATOR FROM ELECTRIC SHOCK.

The plug must be plugged into a matching outlet that is properly installed and grounded in accordance with all local codes and ordinances.

Do not modify the plug provided—if it will not fit the outlet, have the proper outlet installed by a qualified electrician.

Improper connection of the equipment-grounding conductor can result in risk of electric shock. The conductor with insulation having an outer surface that is green with or without yellow stripes is the equipment-grounding conductor. If repair or replacement of the electric cord or plug is necessary, do not connect the equipment-grounding conductor to a live terminal.

Check with a qualified electrician or service personnel if the grounding instructions are not completely understood, or if in doubt as to whether the machine is properly grounded.

Use only 3-wire extension cords that have 3-pronged grounding type plugs and matching 3-conductor receptacles that accept the machine's plug, as shown in Fig. A. Repair or replace damaged or worn cord immediately.

MINIMUM GAUGE FOR CORD SETS

Use proper extension cords. Make sure your extension cord is in good condition and is a 3-wire extension cord which has a 3-pronged grounding type plug and matching receptacle which will accept the machine's plug. When using an extension cord, be sure to use one heavy enough to carry the current of the machine. An undersized cord will cause a drop in line voltage, resulting in loss of power and overheating. The table shows the correct gauge to use depending on the cord length. If in doubt, use the next heavier gauge. The smaller the gauge number, the heavier the cord.

Ampere rating of the tool (120V circuit only)		Total length of cord			
		25' (7.62 m)	50' (15.24 m)	100' (30.48 m)	150' (45.72 m)
more than	not more than	Minimum Gauge for the extension cord (AWG)			
0	6	18	16	16	14
6	10	18	16	14	12
10	12	16	16	14	12
12	16	14	12	Not recommended	

WARNING!

In all cases, make certain the receptacle in question is properly grounded. If you are not sure, have a electrician check the receptacle.

Package contents

No.	Description	Qty.
1	Belt / disc sander (not shown)	1
2	Belt work table	1
3	Inner hex bolt	1
4	Flat washer	1
5	Support rod	1
6	Belt tension handle	1
7	Disc work table	1
8	Disc table locking knob	1
9	Flat washer + Spring washer	2
10	Miter gauge	1
11	Inner hex wrench	3

2

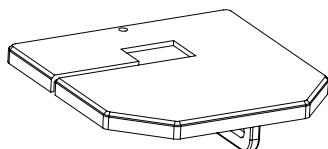

3



4



5



6

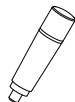

7

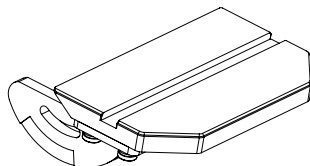

8



9



10

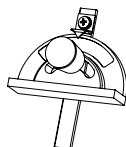

11

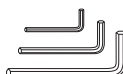

⚠ WARNING!

Do not plug in or turn on the tool until it is fully assembled according to the instructions. Failure to follow the safety instructions may result in serious personal injury.

INSTALL SANDING BELT TABLE

1. Install the support rod (1) to the belt frame (2).
2. Pass the sanding belt (3) through the slot on the belt table (4) and position the table on the machine.
3. Secure the belt table into position using the flat washer (5) and inner hex bolt (6).

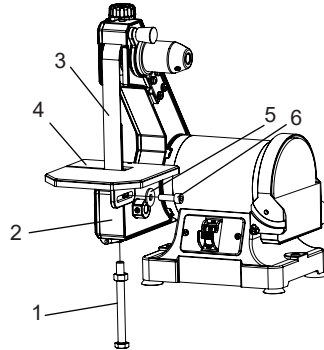
**INSTALL SANDING DISC TABLE**

1. Hold the disc table (1) at an upwards angle of 45°. Align the inner extrusions on the disc table with the slot on left side of the sanding disc. Slide inwards then upwards.
2. Align the flat washer (2), spring washer (3) and locking knob (4) with the hole on left side of the sanding disc. Turn clockwise to secure the disc table into place.

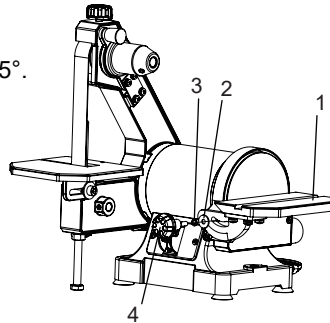
**⚠ WARNING!**

To avoid trapping the workpiece or fingers between the table and the sanding disc, the table edge should be adjusted to a maximum of 1/16 inch from the sanding disc.

INSTALLING TENSION HANDLE

Screw the tension handle (1) into the hole (2) of the hub and lock it.

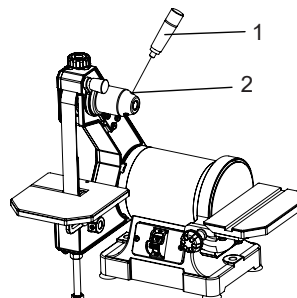

MOUNTING BELT / DISC SANDER TO WORKBENCH

1. Place the sander on a surface that is level but also provides enough room on all sides for the workpiece and for the operator (or bystanders) to not be standing in line with the wood while using the tool.

NOTE: The hardware to mount this sander is NOT supplied with the sander.

ADJUSTING DISC TABLE SQUARE WITH SANDING DISC

1. Using a combination square (1), place one side of the square on the disc table (2) with the other side against the sanding disc (3), and check to see if the disc table is 90° to the disc.
2. If the disc table surface is not 90° to the disc, loosen the table locking knob (4), adjust table square with disc and tighten the table locking knob (4).
3. Loosen the screw and secure the scale pointer at 0°.

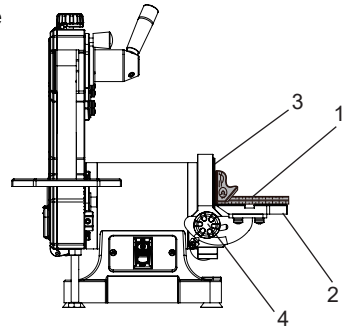

NOTE: The disc table (2) can be tilted from 0° to 45° by loosening the table locking knob (4). Tilt the disc table (2) to the desired angle. Tighten table locking knob (4).

TO PROPERLY TRACK THE SANDING BELT

1. Plug in the sander.
2. Turn power switch ON, then immediately OFF, noting whether the belt (1) tends to slide off its track, and to which side of the sander.
3. If the sanding belt does not slide to either side, it is tracking properly.
4. Viewed from the switch end, if the sanding belt runs toward the disc side, slightly turn the tracking knob (2) counterclockwise (down).
5. Viewed from the switch end, if the sanding belt runs away from the disc side, slightly turn the tracking knob (2) clockwise (up).
6. Turn power switch ON, then immediately OFF again, again taking note of any belt movement.

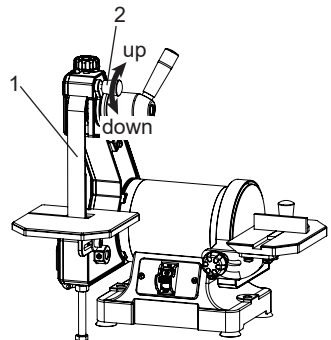

ON/OFF SWITCH

The ON/OFF power switch is located on the front of the sander, and incorporates a removable safety key.

In situations where the sander may be left unattended, the operator has the option of removing the safety key of the ON/OFF switch to render the sander inoperable. When the operator is ready to use the machine again, simply insert the safety key into the slot in the switch and pushing it in until it "seats."

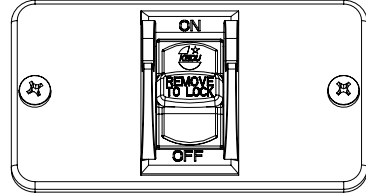

BELT SANDER PLATEN

The belt platen (1) is used to properly support the workpiece while sanding. The platen (1) is constructed of heavy steel to provide adequate support.

The platen (1) should be adjusted so it is almost touching the back of the abrasive belt. Loosen the socket head cap screw (2) and adjust the platen (1) to the desired position. Tighten the screw (2) to secure the platen (1).

The platen can be removed for operations such as stripping, contour sanding, polishing or other special operations. To remove the platen, remove the socket head cap screw and washer.

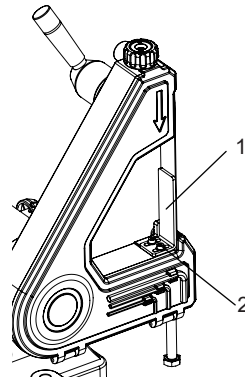

NOTE: Be sure to re-install the platen to perform operations where support of the belt is required

REPLACING SANDING DISC

A sanding disc is pre-mounted at the factory. Use only sanding discs that measures 5 in. (125 mm) in diameter.

1. Remove the disc worktable (1) and then remove the disc cover (2) by removing two screws.
2. Remove the existing disc, and clean any residue left on disc plate. Only use mineral spirits to remove this residue.
3. Peel the backing from the new sanding disc, align the disc with the plate and press the sanding disc firmly on to the plate.
4. Reinstall the disc cover (1), tighten two screws (2) and place sanding table back on unit.

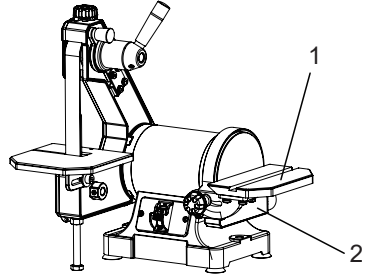
**REPLACING SANDING BELT**

1. Turn the knob (1) clockwise to open the belt cover (2).
 2. Release belt tension by pulling down on tension handle (3). Slide old belt off the drive and tracking wheels.
- NOTE:** The sanding belt can be removed directly without removing the belt work table.
3. Install the new belt around the wheels.
 4. Lift the belt cover and turn the knob (1) counterclockwise to fix it.
 5. Start the sander and check the belt tracking before sanding operations (See "TO PROPERLY TRACK THE SANDING BELT").

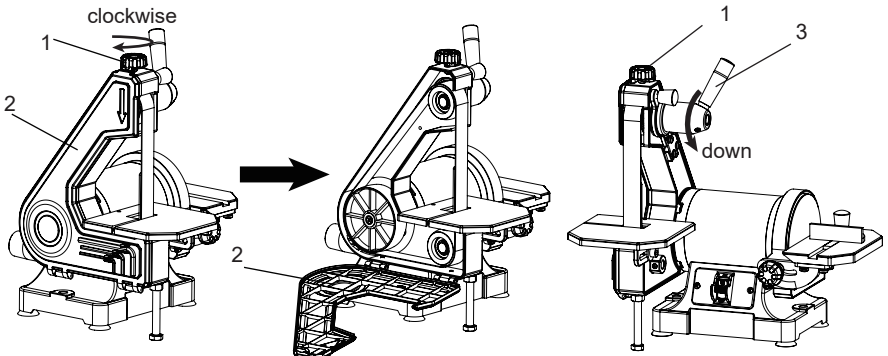

WARNING!

To avoid injury from an accidental start, turn the switch OFF and always remove the plug from the power source before making any adjustments.

PROBLEM	PROBLEM CAUSE	SUGGESTED CORRECTIVE ACTION
Motor will not start—fuses or circuit breakers tripping / blowing	<ol style="list-style-type: none"> 1. Short circuit in line, cord or plug. 2. Short circuit in motor or loose connections 3. Incorrect fuses or circuit breakers in power line. 	<ol style="list-style-type: none"> 1. Inspect cord or plug for damaged insulation and shorted wires. 2. Inspect all connections on motor for loose or shorted terminals and/or worn insulation. 3. Install correct fuses or circuit breakers or switch tool to an appropriately sized circuit.
Motor overheats	<ol style="list-style-type: none"> 1. Motor overloaded 2. Extension cord too long with an insufficient gauge. 	<ol style="list-style-type: none"> 1. Reduce load on motor (pressure on object being sanded) 2. Utilize an extension cord of appropriate gauge and length or plug tool directly into outlet.
Sander does not turn on	<ol style="list-style-type: none"> 1. Not plugged in to an electrical outlet 2. Defective power switch 3. Motor, capacitor, or wiring problem 	<ol style="list-style-type: none"> 1. Connect the unit to an outlet. 2. Replace the switch. 3. Contact customer service.
Sanding surface clogs quickly	<ol style="list-style-type: none"> 1. Too much pressure against belt/disc 2. Sanding softwood. 	<ol style="list-style-type: none"> 1. Reduce pressure on workpiece while sanding. 2. Use different stock/sanding accessories, or accept that this will happen and plan on cleaning or replacing belts/discs frequently.
Deep sanding grooves or scars in workpiece	<ol style="list-style-type: none"> 1. Sanding belt/disc grit is too coarse for the desired finish. 2. Workpiece sanded across the grain. 3. Too much sanding force on workpiece. 4. Workpiece held still against belt-disc for too long. 	<ol style="list-style-type: none"> 1. Use a finer-grit sanding accessory. 2. Sand with the grain of the wood. 3. Reduce pressure on workpiece while sanding. 4. Keep workpiece moving while sanding on the sanding accessory.

EXPLODED VIEW

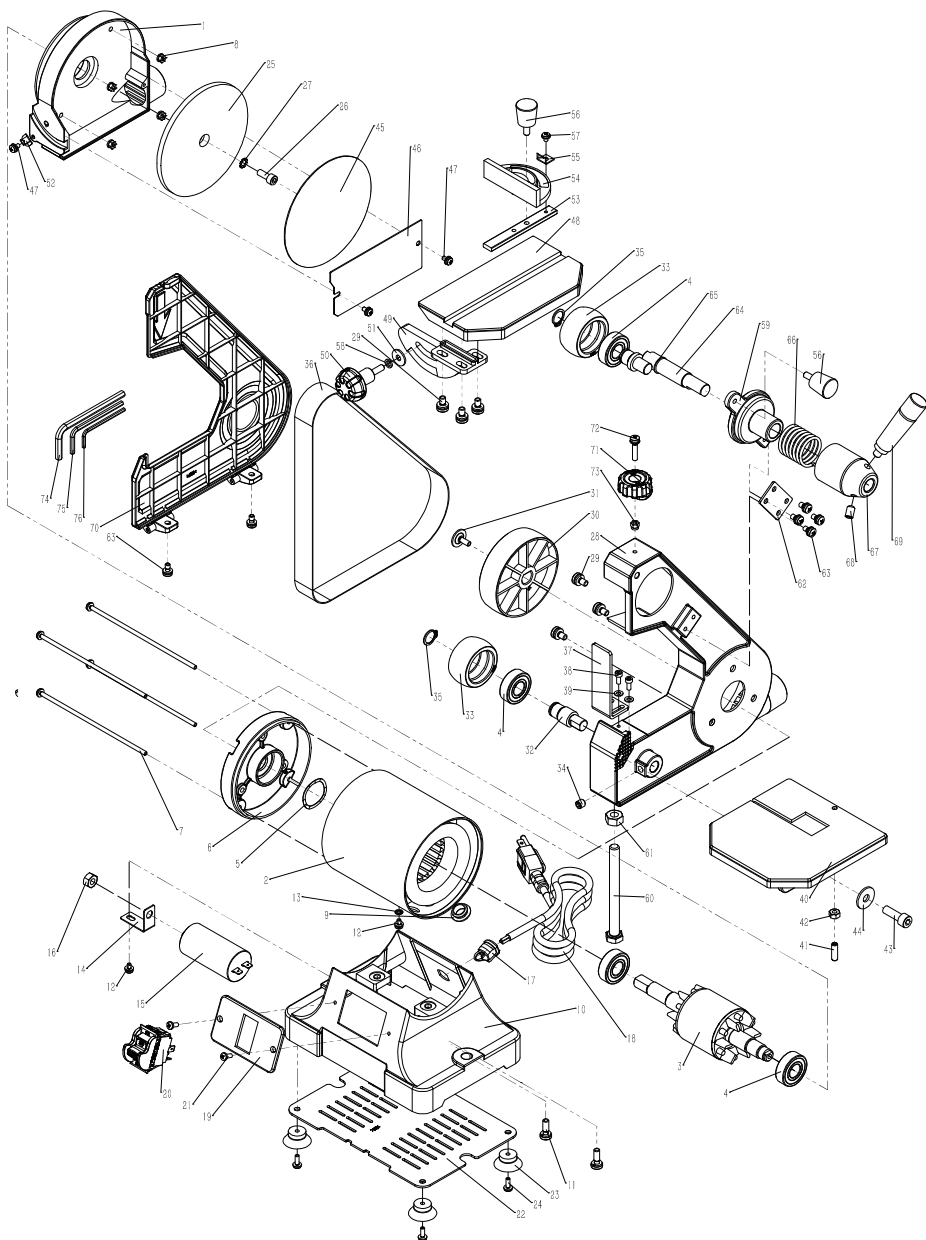

Item	Description	Qty.	Item	Description	Qty.
1	sanding disc guard cover	1	39	flat washer D4	2
2	stator	1	40	belt work table	1
3	rotor	1	41	inner hex bolt M6x20	1
4	bearing	4	42	hex nut M6	1
5	wave spring washer	1	43	inner hex bolt M8x256	1
6	end cap	1	44	big flat washer D8	1
7	philips screw assy M4x153	4	45	sanding disc paper	1
8	hex nut M4	4	46	disc palte	1
9	cord bushing	1	47	philips screw assy M4x8	3
10	base	1	48	disc work table	1
11	philips screw assy M6x18	2	49	work table support	1
12	philips screw assy M4x7	2	50	work table locking knob	1
13	tooth lock washer D4	1	51	big flat washer D6	1
14	capacitor support	1	52	pointer	1
15	capacitor	1	53	Miter Gauge slide bar	1
16	hex nut M8	1	54	miter gauge	1
17	cord clip	1	55	pointer	1
18	power cord	1	56	miter gauge knob	2
19	switch plate	1	57	philips screw M4x6	1
20	switch	1	58	spring washer D6	1
21	philips screw	2	59	Support Base	1
22	base plate	1	60	hex bolt M10x110	1
23	rubber foot	4	61	hex nut M10	1
24	philips screw M4x12	4	62	belt adjustable plate	1
25	sanding disc plate	1	63	philips screw M5x10	6
26	inner hex bolt M6x16	1	64	Eccentric Shaft Assy	1
27	tooth lock washer D6	1	65	circlip for shaft D16	1
28	belt support	1	66	tension spring	1
29	philips screw assy M6x12	6	67	tension handle base	1
30	main wheel	1	68	inner hex bolt M8x12	1
31	philips screw assy M5x16	1	69	belt tension handle	1
32	idler shaft	1	70	belt plate assy	1
33	idler wheel	2	71	locking knob	1
34	inner hex bolt M8x8	1	72	philips screw assy M5x25	1
35	circlip for shaft D15	2	73	hex nut M5	1
36	sanding belt	1	74	inner hex wrench s=6	1
37	belt limit plate	1	75	inner hex wrench s=4	1
38	inner hex bolt M4x10	2	76	inner hex wrench s=3	1

WARRANTY



TWO-YEAR LIMITED WARRANTY

Having Problems ?

Give us a chance to help you before returning this product

Email : service@bucktool.com

<https://www.bucktool.com>



Instagram



Bucktool

<https://www.bucktool.com>