

Agua

CLD-60GD-II
Porte de douche

CLD-60GD-II
Shower door



SPECIFICATIONS

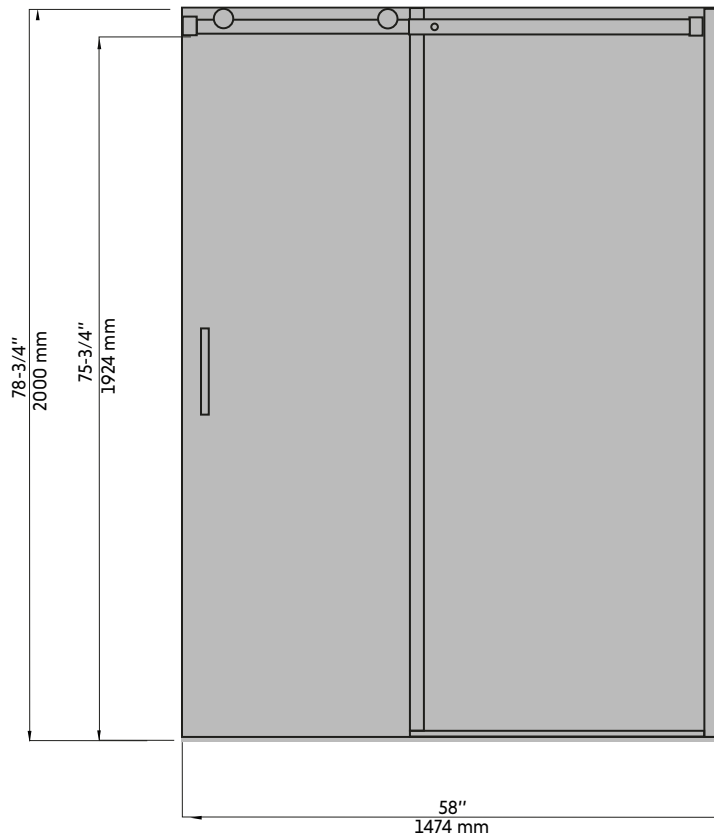
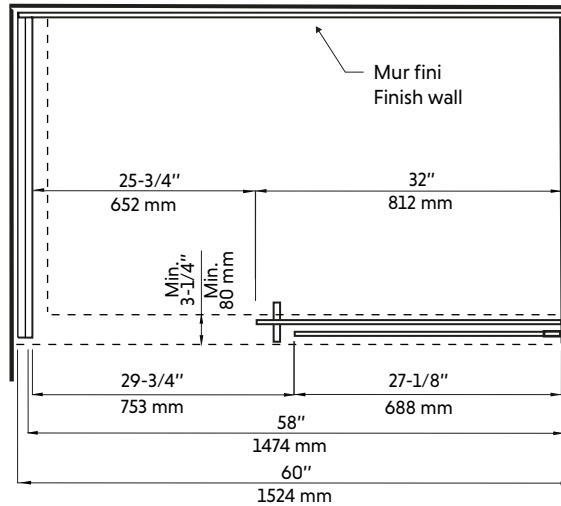

AVANT TOUT / BEFORE EVERYTHING

FRANCAIS

Nos produits sont soigneusement inspectés en usine et emballés pour l'expédition. Il est important de bien inspecter le produit avant l'installation. Si un item défectueux est installé, l'installateur sera tenu responsable de tous bris ou dommages a la suite de l'utilisation du produit défectueux. Pour protéger l'item durant l'installation il est recommandé de placer un morceau de carton dans le fond de la base de douche.

ENGLISH

Our products are carefully inspected and package in our warehouse for shipping. Its very important that you carefully inspect the product before installation. The installer will be held responsible for any breakeage or damages following the use of a defective product. To protect the unit during installation, place a cardboard in the bottom of the shower base.

PIÈCES D'INSTALLATION / INSTALLATION PARTS

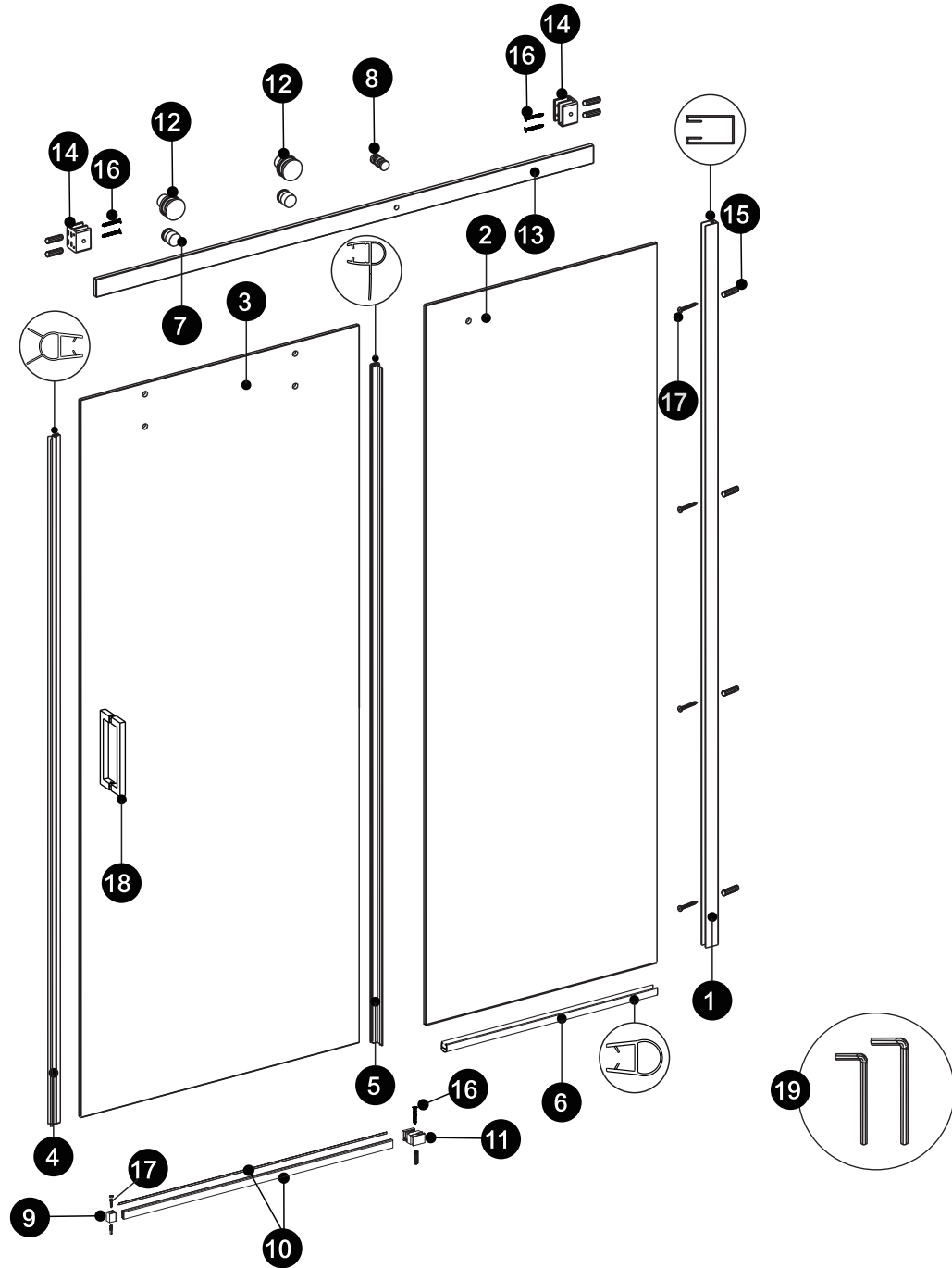

n°	DESCRIPTION	Quantité/ Quantity	n°	DESCRIPTION	Quantité/ Quantity
1	Montants de mur / Wall Jambs	1pc	11	Bloc coulissant (G/D) /Sliding Block(L/R)	1 ens/set
2	Panneau fixe / Fixed Panel	1pc	12	Ensemble de rouleaux / Roller Sets	2 ens/sets
3	Joint de panneau de porte / Door Panel	1pc	13	Rail supérieur / Top rail	1pc
4	Joint-A / Gasket-A	1pc	14	Joints muraux carrés/ Square Wall Joints	1 ens/set
5	Joint-B / Gasket-B	1pc	15	Prises murales / Wall Plugs	10pcs
6	Joint-C / Gasket-C	1pc	16	Vis-A / Screws-A ST4x1 3/8"	5pcs
7	Ensembles de boutons de verrouillage / Lock In Knob Sets	2 ens/sets	17	Vis-B / Screws-A ST4x1 3/8"	5pcs
8	Pièce de fixation en verre / Glass Fixing Piece	1 ens/set	18	Poignée / handle"	1 ens/set
9	Capuchon du rail d'égouttement / drip rail cap	1 ens/set	19	Clé Allen /Allen Wrench	2pcs
10	Rail anti-goutte / Anti-drip rail	1 ens/set			

INSTALLATION

1

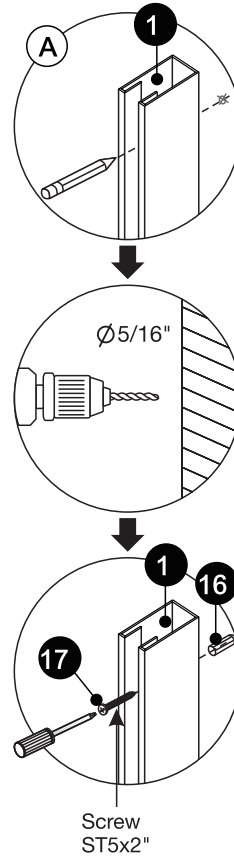
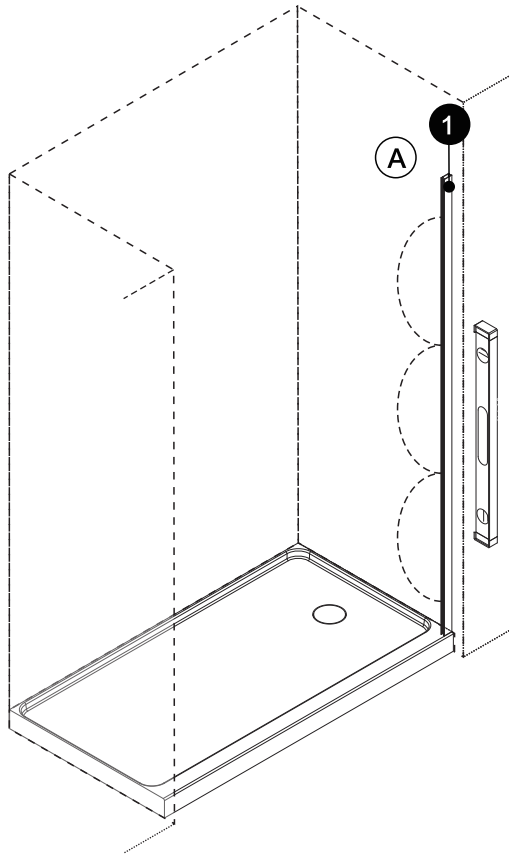

2

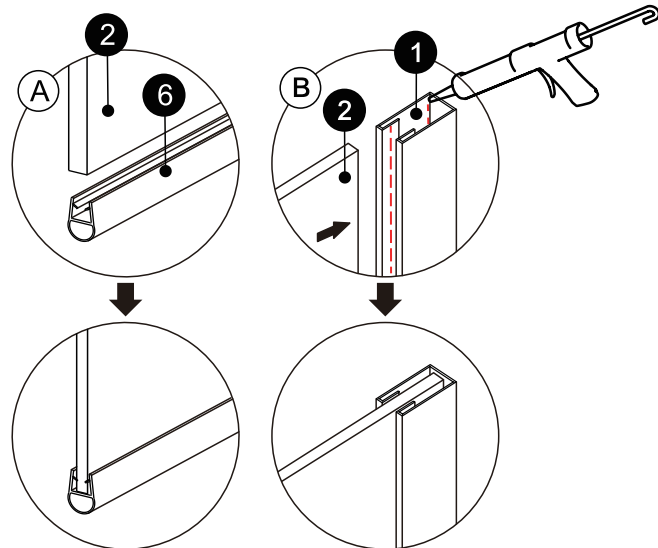
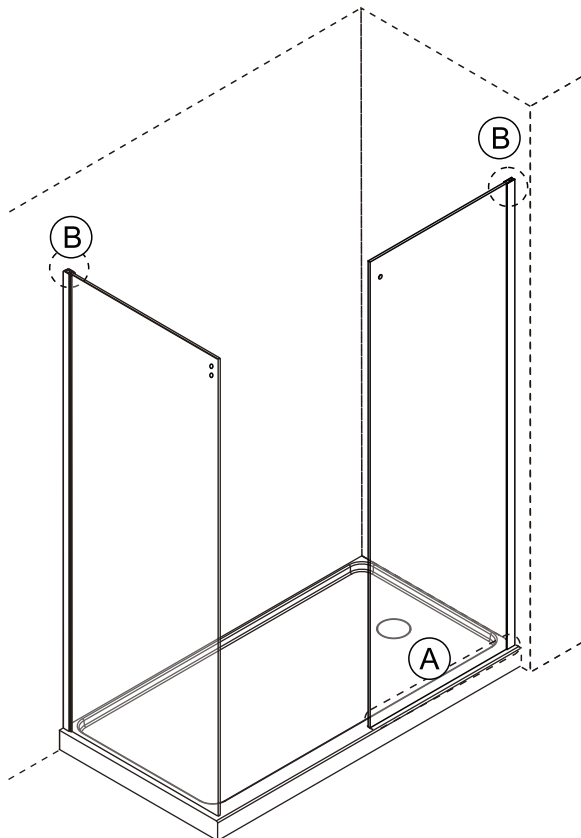

INSTALLATION

3

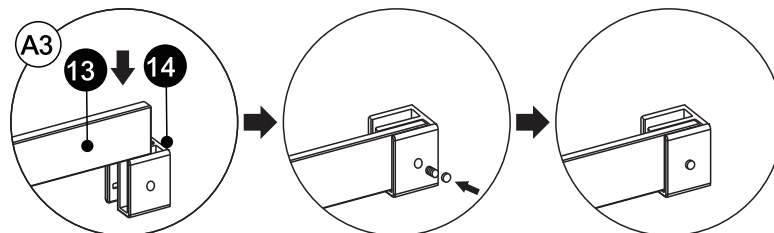
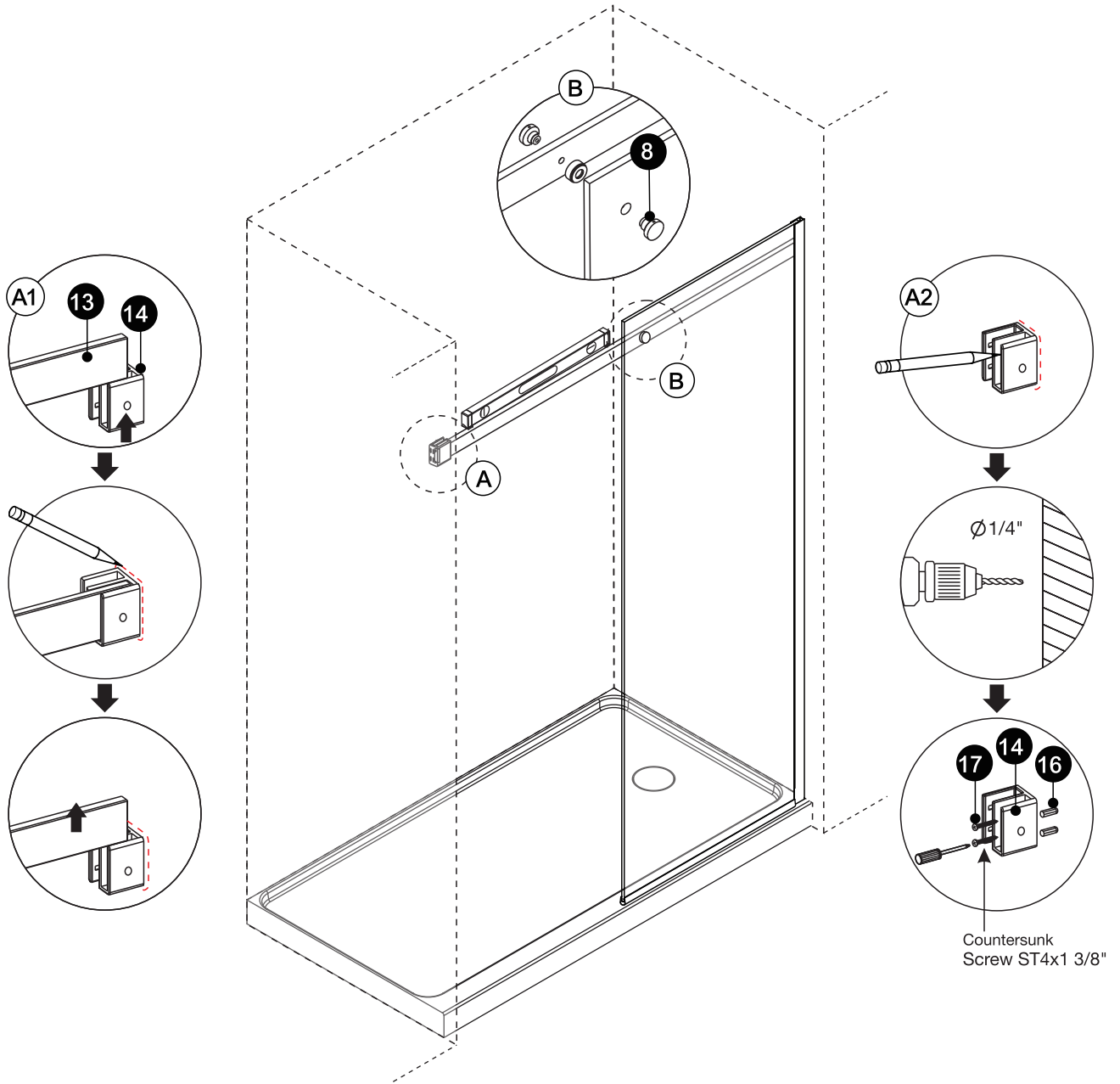

INSTALLATION

4

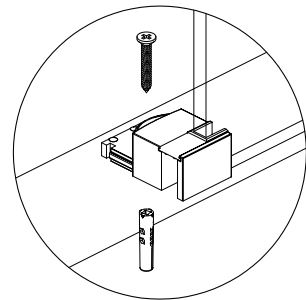
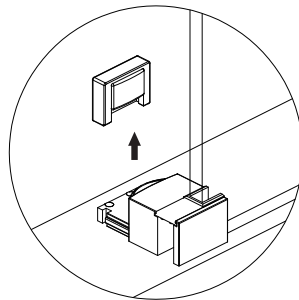
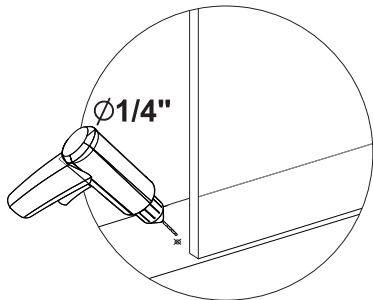
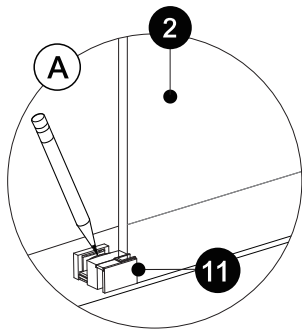
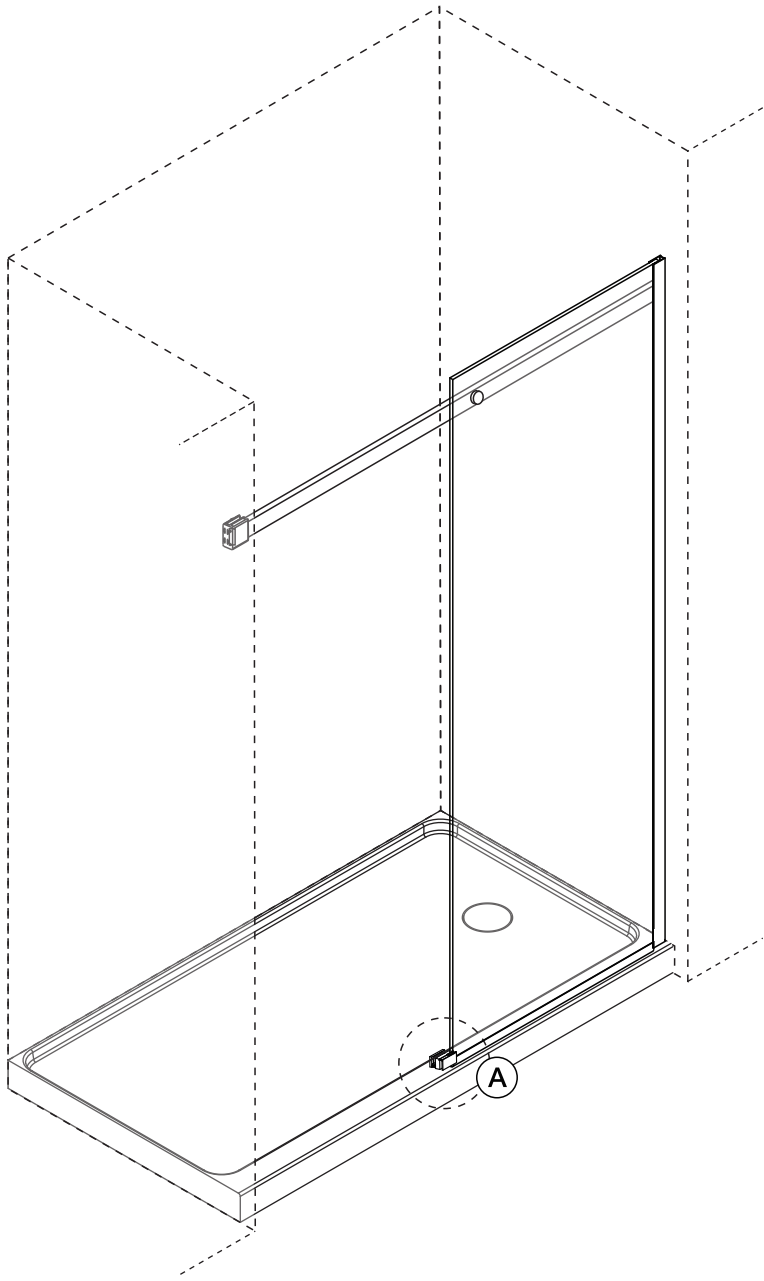

INSTALLATION

5

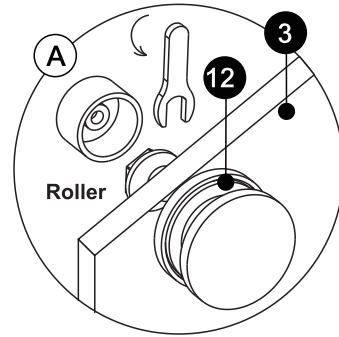
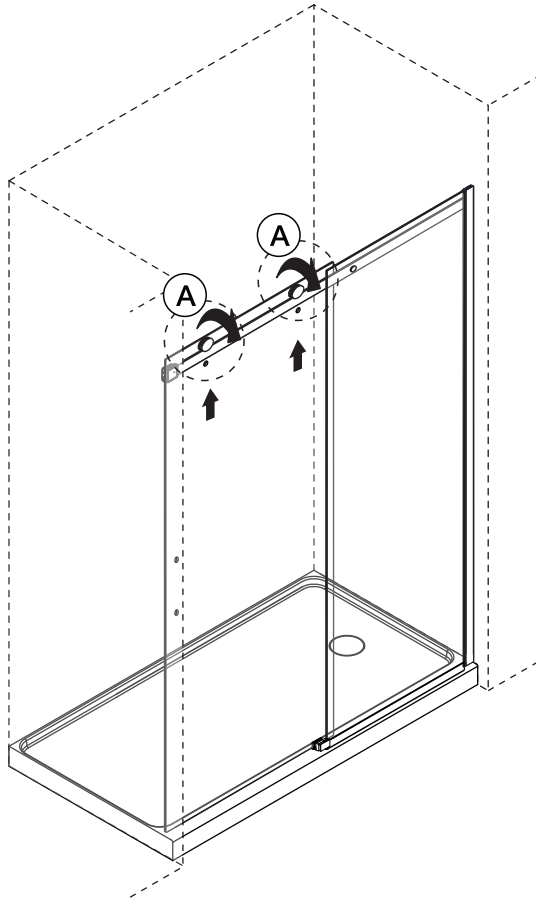

6

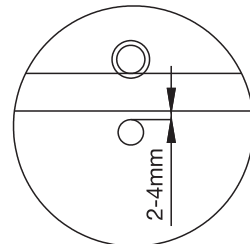
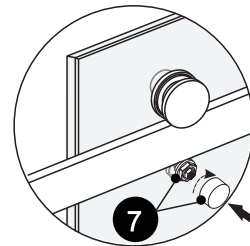
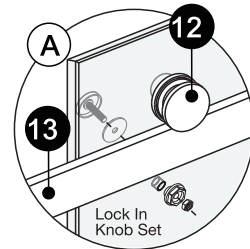
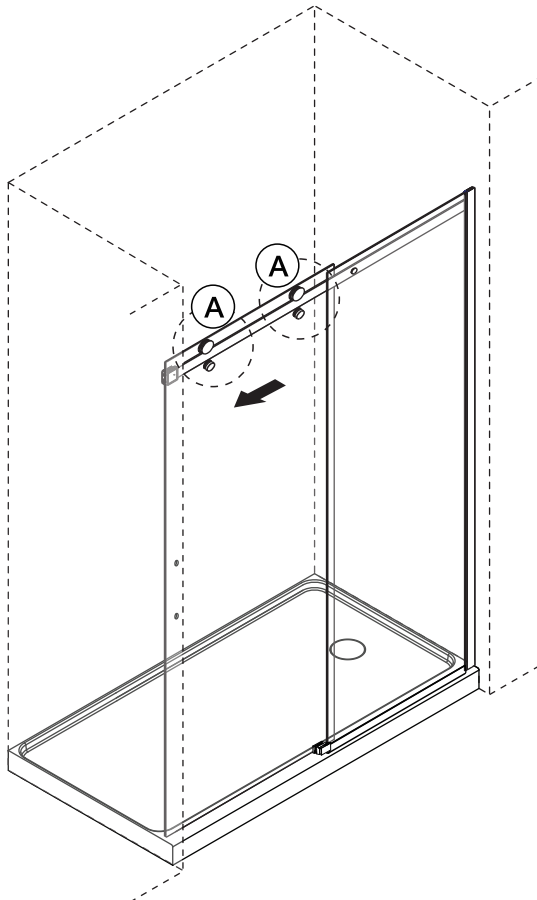

INSTALLATION

7

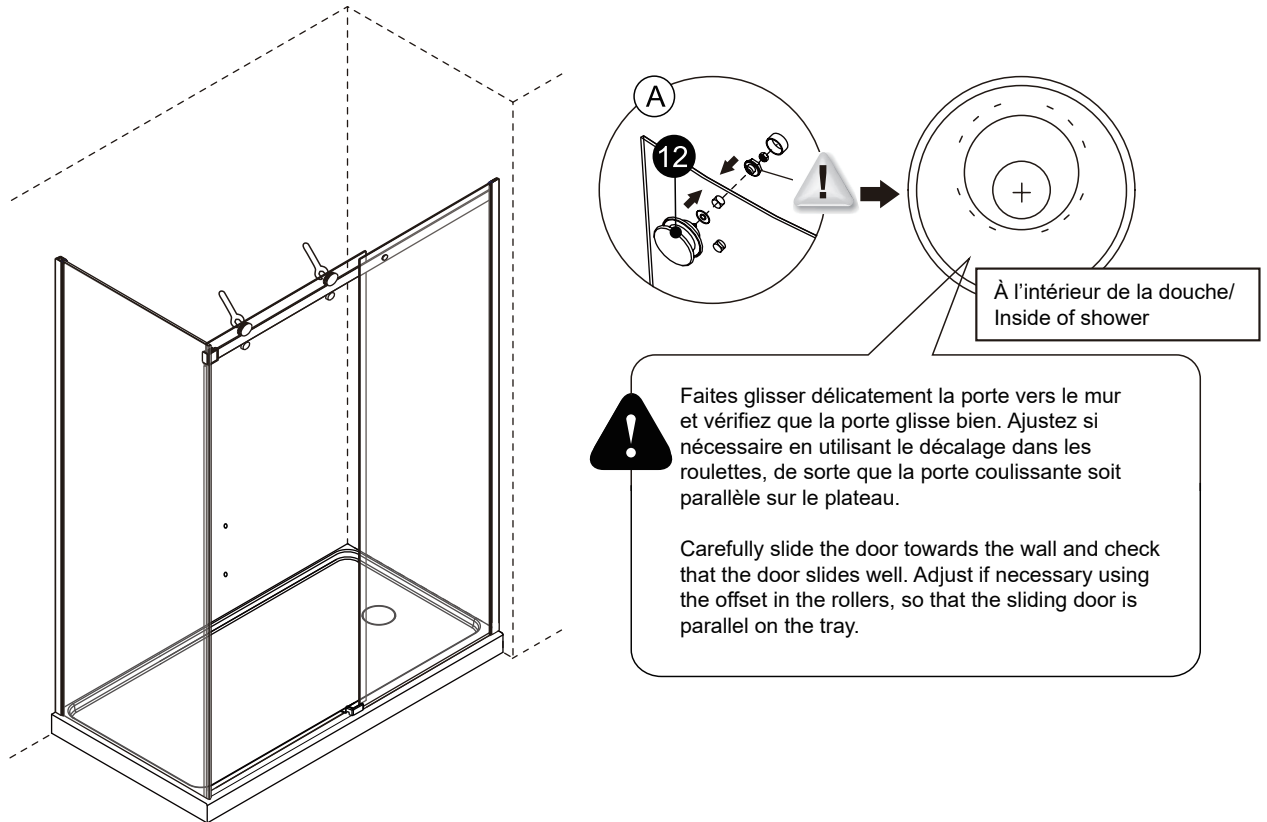

8

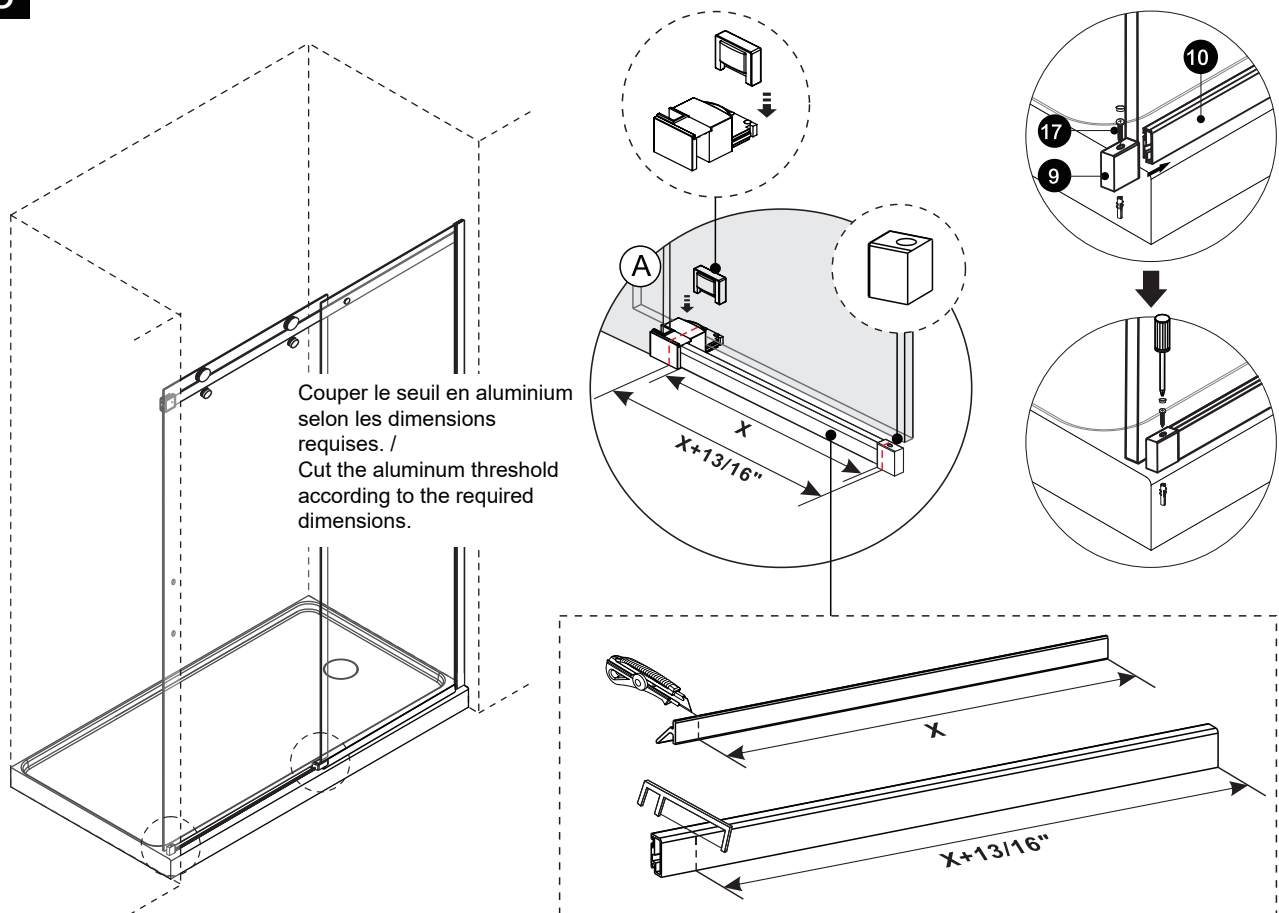

INSTALLATION

9

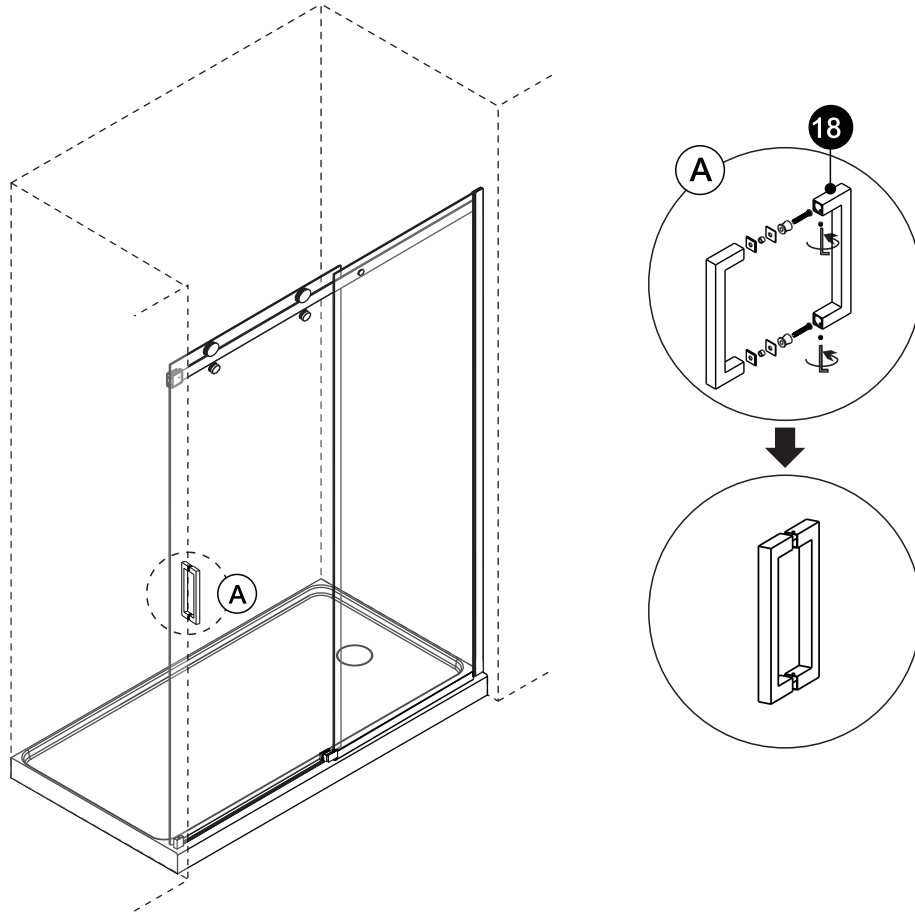

10

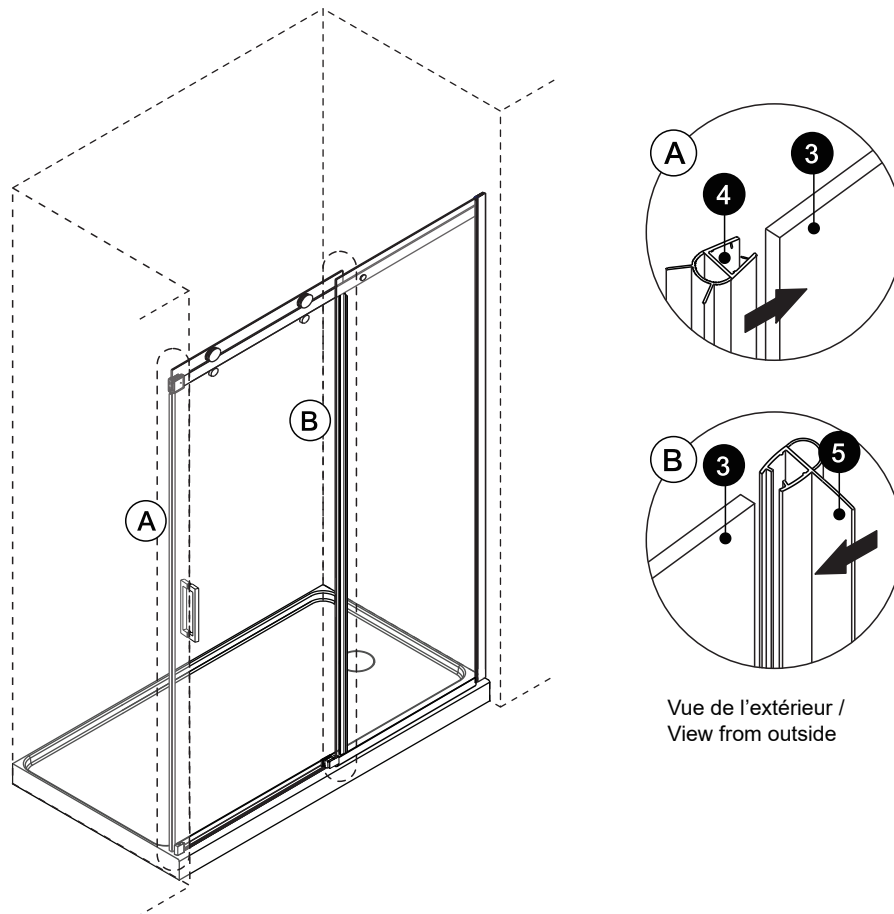



24 HOURS

Attendez 24 heures que le silicone sèche avant de l'utiliser.
Wait 24 hours for the silicone to dry before using.

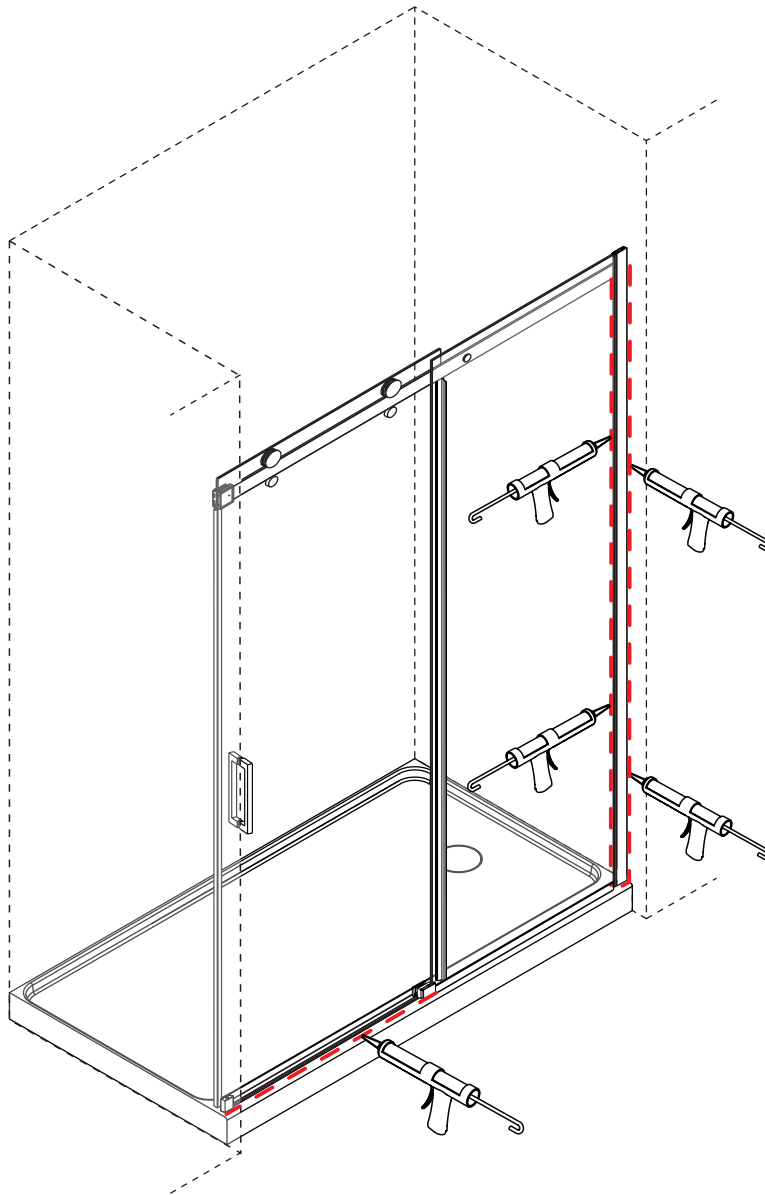

GARANTIE / WARRANTY

FRANÇAIS

Agua Canada garantit ses produits contre tout défaut de matériel ou de fabrication dans des conditions normales d'utilisation et d'entretien. La garantie peut varier en fonction du type de produit.

Agua Canada procédera à sa discrétion à la réparation ou au remplacement de pièces, ou de produits trouvés défectueux pour un usage domestique normal pour lequel ils ont été conçus.

Agua Canada n'est aucunement responsable des frais de main-d'oeuvre ou tous les autres frais reliés à l'installation d'un produit, sa réparation ou son remplacement ainsi que pour tout dommage ou incident, dépense, perte directe ou indirecte.

ENGLISH

Agua Canada warrants all its products against material or workmanship defects under normal conditions of use and maintenance. The warranty period may vary depending on the type of product.

Agua Canada will, at its discretion, repair or replace parts or products that are found defective for the normal home use for which they were designed.

Agua Canada is not responsible in any way for costs related to labour or any other costs related to a product's installation, repair or replacement, nor for any damage, incident, expense, or direct or indirect loss.

PORTE DE DOUCHE/ SHOWER DOOR

Garanties pour une durée de dix (10) ans contre les défauts de fabrication.

/ Guaranteed for a period of ten (10) years against defects in manufacturing

Siege social / Head office

2732 Étienne Lenoir, Laval

Québec, H7R 0A3, Canada

SERVICE@AGUACANADA.COM



aguacanada.com

833 689-2482