



OUTLAND LAURENTIAN SPECIFICATIONS

HARDTAIL 29er MTB

FRAMESET

FRAME Hydroformed 6061 Aluminum Alloy 29er frame with smooth welds. Rack mounts, internal cable routing, Electronic Access Port. Removable integrated battery with security lock.

COLOR Matte Race Red & Burgundy
FORK SUNTOUR XCM HLO DS 29r suspension, 100mm travel, lockout

DRIVETRAIN

SHIFTERS SRAM X5 9-speed trigger shift
CHAINRINGS 44T
CHAIN KMC X9
REAR DERAILLEUR SRAM X5 9-speed long cage
CASSETTE SRAM 9-speed 11-34T

COMPONENTS

HANDLEBAR Low-rise, 720mm, 28mm rise, 31.8mm dia.
GRIPS VELO with lock ring (131mm)
STEM Alloy 50mm with 6 degree rise, 31.8mm clamp dia.
SEAT POST Alloy 31.6mm with quick release
SADDLE SELLE ROYAL
BRAKE LEVERS TEKTRO with Sensor Control Design and reach adjustment
BRAKE CALIPERS TEKTRO hydraulic disc
ROTOR 180mm

WHEELS

TIRES SCHWALBE Smart Sam 29"x2.25"
RIMS Alloy 29r

ACCESSORIES

INCLUDED Dropout Rack Mount Eyelets
 Water Bottle Boss on Down Tube
 Kickstand
 Tool Kit
 Battery Charger

NOTES

BIKE WEIGHT 23.1kg (51.0 lbs)
BATTERY WEIGHT 3.1kg (6.8 lbs)
WEIGHT CAPACITY 114 kg (250 lbs)

ELECTRIC TECHNOLOGY

IGO CONNECT Mobile App (Android and iOS)
 Customizable profile and performance settings with full diagnostic monitoring and alerts - Bluetooth connectivity

DISPLAY UNIT TFT Color Backlit, Main Power, Vibration Feedback Buttons, Diagnostic, Battery Status, Light Switch, Pedal Assist Level Selector, Walk Assist Control, Speedometer/Max Speed/Avg Speed, Odometer, Trip Timer

MOTOR 500W geared rear hub drive, 48V (750W US)
TORQUE up to 53Nm

CONTROLLER 48V high power density sine wave, MOSFET based up to 70 Amp, Bluetooth

BATTERY TYPE 3500mAh SAMSUNG integrated removable lithium battery with security lock

VOLTAGE 48V
BATTERY Ah 14Ah
BATTERY CAPACITY 672Wh
RANGE 70km (45mi) *
POWER ASSIST 5 Levels of power assisted pedaling ***
THROTTLE Any time on demand thumb throttle (Removable)
SENSOR Dual sided 36 pulse Torque Sensor
CLASS Class2 / Class 1 optional / Class3 capable where permitted max speed 45km/h (28mph) **

BATTERY CHARGER 110/220V Smart charger, LED status, UL, 2A

*Actual range may vary depending on Ah of battery rider weight and other riding conditions.

**electric bike class regulation:

Class 1 - Pedal assist motor with maximum assisted speed 32km/h (20mph)
 Class 2 - Pedal assist motor and throttle with maximum assisted speed 32km/h (20mph)
 Class 3 - Throttle and/or pedal assist motor with maximum assisted speed 45km/h (28mph)
 all classes allow a maximum motor power of 750W(US) or 500W(Canada)

This bike is sold factory configured to CLASS 2 specifications.
 User configurable to CLASS 1 or CLASS 3

***Multiple rider profiles available. Always check the specific state/provincial laws for use of class 3 electric bikes and only engage Off Road Mode where this is permitted.

LAURENTIAN

HARDTAIL 29er MTB

GEOMETRY (in mm unless stated)

FRAME SIZE	43cm (17")
A STAND OVER HEIGHT	77.5cm (30.5")
B SEAT TUBE LENGTH	427
C SEAT TUBE ANGLE	70.9°
D EFFECTIVE TOP TUBE LENGTH	628
E REACH	442
F HEAD TUBE LENGTH	130
G HEAD TUBE ANGLE	68.6°
H BOTTOM BRACKET HEIGHT	340
I BOTTOM BRACKET DROP	47
J CHAINSTAY LENGTH	490
K CRANK LENGTH	170
L WHEELBASE	1214

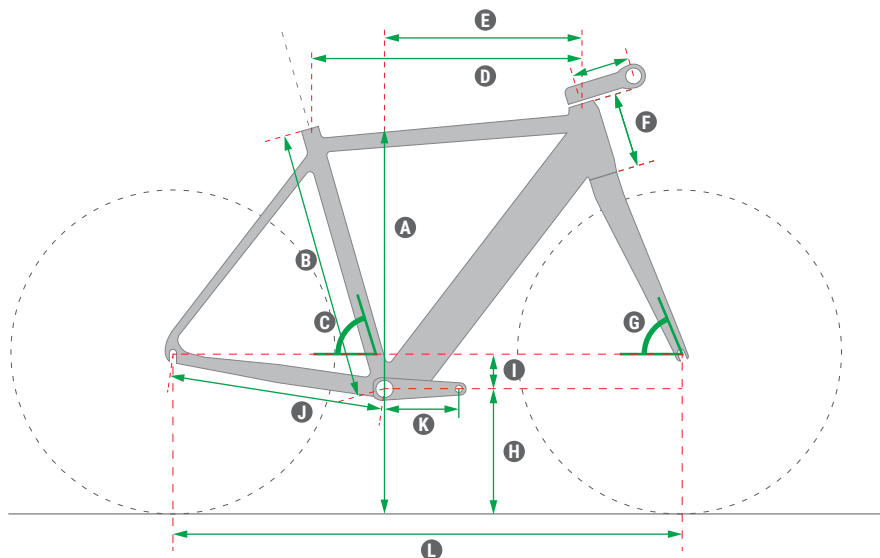

The Future is Electric®