



DISCOVERY BONAVENTURE SPECIFICATIONS

HYBRID BIKE

FRAMESET

FRAME	Hydroformed 6061 Aluminum 700 hybrid ERGOFIT frame with smooth welds. Fender/rack mounts, internal cable routing, Electronic Access Port. Removable integrated battery with security lock.
COLOR	Gloss Moonlight Blue with Nickel Accents
FORK	SUNTOUR NEX 700C suspension, 63mm travel, hydraulic lockout

DRIVETRAIN

SHIFTERS	SHIMANO ALTUS 8-speed Rapidfire trigger shift
CHAINRINGS	PROWHEEL 42T
CHAIN	KMC Z8
REAR DERAILLEUR	SHIMANO ALTUS 8-speed
CASSETTE	8-speed 11-34T

COMPONENTS

HANDLEBAR	Alloy ERGOFIT touring bar
GRIPS	VELO double density, anatomic design, open end (135mm)
STEM	Toolless, multi adjustable
SEAT POST	Alloy 31.6mm with quick release
SADDLE	VELO for iGO
BRAKE LEVERS	TEKTRO with Sensor Control Design and reach adjustment
BRAKE CALIPERS	TEKTRO hydraulic disc
ROTORS	180mm

WHEELS

TIRES	MAXXIS Re-Volt 700x47, 28"x1.75", with SilkShield bead-to-bead puncture protection, reflective sidewall
RIMS	ALEX DP25 700C - black alloy

ACCESSORIES

INCLUDED	Front BUCHEL Shiny 50 lux LED Light (powered by main battery) Rear BUCHEL Edge LED Light (powered by main battery) Front & Rear Alloy Fenders Integrated Alloy Rear Cargo Rack Rear Bungee Straps Chain Guard Water Bottle Boss on Seat Tube Kickstand Tool Kit Battery Charger
----------	--

NOTES

BIKE WEIGHT	25.0kg (55.2 lbs)
BATTERY WEIGHT	3.1kg (6.8 lbs)
WEIGHT CAPACITY	114 kg (250 lbs)

ELECTRIC TECHNOLOGY

iGO CONNECT	Mobile App (Android and iOS) Customizable profile and performance settings with full diagnostic monitoring and alerts - Bluetooth connectivity
DISPLAY UNIT	TFT Color Backlit, Main Power, Vibration Feedback Buttons, Diagnostic, Battery Status, Light Switch, Pedal Assist Level Selector, Walk Assist Control, Speedometer/Max Speed/Avg Speed, Odometer, Trip Timer
MOTOR	500W geared rear hub drive, 48V (750W US)
TORQUE	up to 53Nm
CONTROLLER	48V high power density sine wave, MOSFET based up to 70 Amp, Bluetooth
BATTERY TYPE	3500mAh SAMSUNG integrated removable lithium battery with security lock
VOLTAGE	48V
BATTERY Ah	14Ah
BATTERY CAPACITY	672Wh
RANGE	90km (56mi) *
POWER ASSIST	9 Levels of power assisted pedaling ***
THROTTLE	Any time on demand thumb throttle (Removable)
SENSOR	Electronic 32 pulse Cadence Sensor integrated into the bottom bracket
CLASS	Class2 / Class 1 optional / Class3 capable where permitted max speed 45km/h (28mph) **
BATTERY CHARGER	110/220V Smart charger, LED status, CUL, 2A

*Actual range may vary depending on Ah of battery rider weight and other riding conditions.

**electric bike class regulation:

Class 1 - Pedal assist motor with maximum assisted speed 32km/h (20mph)
Class 2 - Pedal assist motor and throttle with maximum assisted speed 32km/h (20mph)
Class 3 - Throttle and/or pedal assist motor with maximum assisted speed 45km/h (28mph)
all classes allow a maximum motor power of 750W(US) or 500W(Canada)

This bike is sold factory configured to CLASS 2 specifications.
User configurable to CLASS 1 or CLASS 3

***Multiple rider profiles available. Always check the specific state/provincial laws for use of class 3 electric bikes and only engage Off Road Mode where this is permitted.

DISCOVERY BONAVENTURE



HYBRID BIKE

GEOMETRY (in mm unless stated)

FRAME SIZE	ERGOFIT Multi Adjustable - accommodates rider from 5' to 6'2"
A SEAT HEIGHT (MIN/MAX)	71cm / 84.5cm (28" / 33")
B STAND OVER HEIGHT	71cm (28")
C SEAT TUBE LENGTH	445
D SEAT TUBE ANGLE	73°
E EFFECTIVE TOP TUBE LENGTH	617
F REACH	417
G HEAD TUBE LENGTH	150
H HEAD TUBE ANGLE	71°
I BOTTOM BRACKET HEIGHT	305
J BOTTOM BRACKET DROP	70
K CHAINSTAY LENGTH	473
L CRANK LENGTH	170
M WHEELBASE	1120

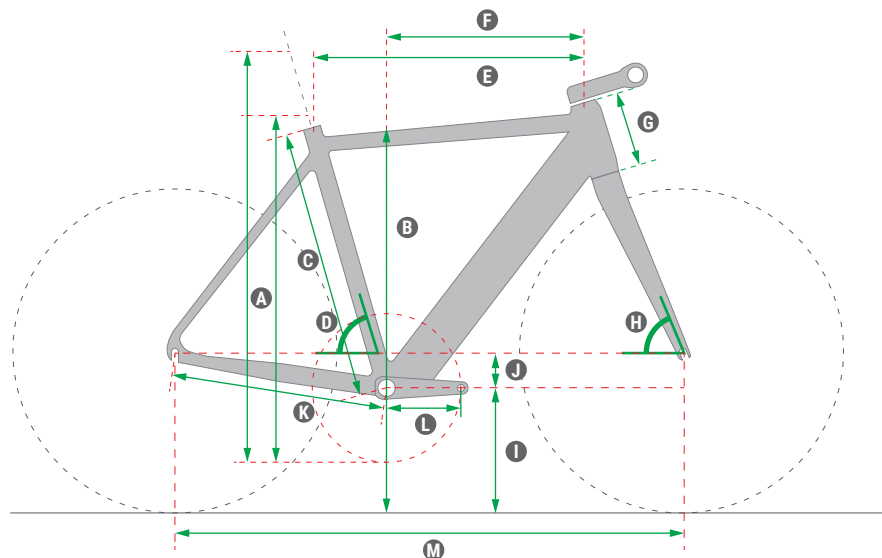

The Future is Electric®