



DISCOVERY BERRI SPECIFICATIONS

26" STEP THROUGH FRAME

FRAMESET

FRAME Hydroformed 6061 Aluminum 26" step through ERGOFIT frame with smooth welds. Fender/rack mounts, internal cable routing, Electronic Access Port. Removable integrated battery with security lock.

COLOR Gloss White with Process Blue Accents
FORK SUNTOUR NEX 26" suspension, 63mm travel

DRIVETRAIN

SHIFTERS SHIMANO ALTUS 8-speed Rapidfire trigger shift
CHAINRINGS PROWHEEL 42T
CHAIN KMC Z8
REAR DERAILLEUR SHIMANO ALTUS 8-speed
CASSETTE 8-speed 11-32T

COMPONENTS

HANDLEBAR Alloy ERGOFIT touring bar
GRIPS VELO double density, anatomic design, open end (135mm)
STEM Toolless, multi adjustable
SEAT POST Alloy 31.6mm with quick release
SADDLE VELO for iGO
BRAKE LEVERS TEKTRO with Sensor Control Design and reach adjustment
BRAKE CALIPERS TEKTRO hydraulic disc
ROTORS 180mm

WHEELS

TIRES MAXXIS Overdrive Excel 26"x2.0" with SilkShield bead-to-bead puncture protection, reflective sidewall
RIMS ALEX DP25 26" - black alloy

ACCESSORIES

INCLUDED Front BUCHEL Shiny 50 lux LED Light (powered by main battery)
Rear BUCHEL Edge LED Light (powered by main battery)
Front & Rear Alloy Fenders
Integrated Alloy Rear Cargo Rack
Rear Bungee Straps
Chain Guard
Water Bottle Boss on Seat Tube
Kickstand
Tool Kit
Battery Charger

NOTES

BIKE WEIGHT 24.0kg (53.0 lbs)
BATTERY WEIGHT 3.1kg (6.8 lbs)
WEIGHT CAPACITY 114 kg (250 lbs)

ELECTRIC TECHNOLOGY

iGO CONNECT Mobile App (Android and iOS)
Customizable profile and performance settings with full diagnostic monitoring and alerts - Bluetooth connectivity

DISPLAY UNIT TFT Color Backlit, Main Power, Vibration Feedback Buttons, Diagnostic, Battery Status, Light Switch, Pedal Assist Level Selector, Walk Assist Control, Speedometer/Max Speed/Avg Speed, Odometer, Trip Timer

MOTOR 500W geared rear hub drive, 48V (750W US)
TORQUE up to 53Nm
CONTROLLER 48V high power density sine wave, MOSFET based up to 70 Amp, Bluetooth

BATTERY TYPE 3500mAh SAMSUNG integrated removable lithium battery with security lock

VOLTAGE 48V
BATTERY Ah 14Ah
BATTERY CAPACITY 672Wh
RANGE 90km (56mi) *
POWER ASSIST 9 Levels of power assisted pedaling ***
THROTTLE Any time on demand thumb throttle (Removable)
SENSOR Electronic 32 pulse Cadence Sensor integrated into the bottom bracket

CLASS Class2 / Class 1 optional / Class3 capable where permitted max speed 45km/h (28mph) **

BATTERY CHARGER 110/220V Smart charger, LED status, CUL, 2A

*Actual range may vary depending on Ah of battery rider weight and other riding conditions.

**electric bike class regulation:

Class 1 - Pedal assist motor with maximum assisted speed 32km/h (20mph)

Class 2 - Pedal assist motor and throttle with maximum assisted speed 32km/h (20mph)

Class 3 - Throttle and/or pedal assist motor with maximum assisted speed 45km/h (28mph)

all classes allow a maximum motor power of 750W(US) or 500W(Canada)

This bike is sold factory configured to CLASS 2 specifications.

User configurable to CLASS 1 or CLASS 3

***Multiple rider profiles available. Always check the specific state/provincial laws for use of class 3 electric bikes and only engage Off Road Mode where this is permitted.

DISCOVERY BERRI



26" STEP THROUGH FRAME

GEOMETRY (in mm unless stated)

FRAME SIZE	ERGOFIT Multi Adjustable - accommodates rider from 4'8" to 6'
A SEAT HEIGHT (MIN/MAX)	68cm / 81.5cm (26.5" / 32")
B SEAT TUBE LENGTH	420
C SEAT TUBE ANGLE	73°
D EFFECTIVE TOP TUBE LENGTH	617
E REACH	430
F HEAD TUBE LENGTH	125
G HEAD TUBE ANGLE	71°
H BOTTOM BRACKET HEIGHT	260
I BOTTOM BRACKET DROP	70
J CHAINSTAY LENGTH	443
K CRANK LENGTH	170
L WHEELBASE	1110

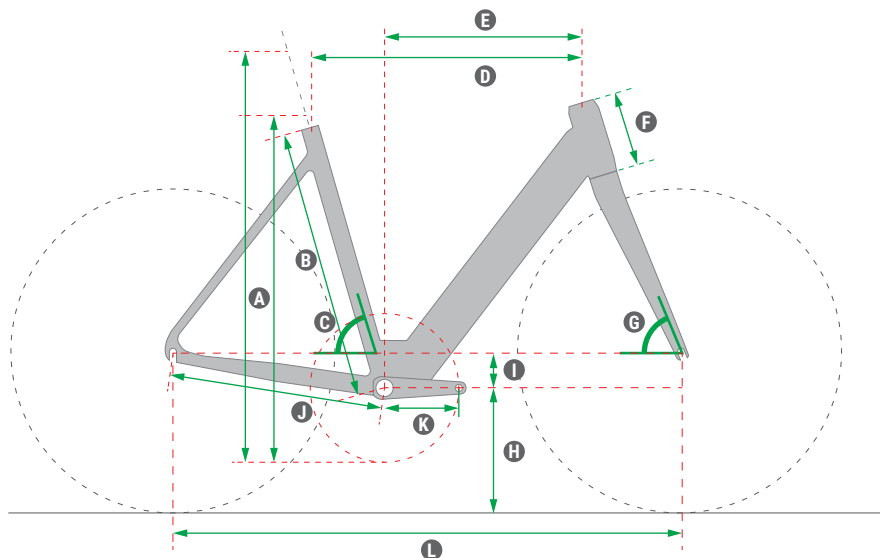

The Future is Electric®