

How to determine axle length by setting the car at ride height using a 3D model:

- Add the provided .step file axle components to your assembly.
- Locate the tripod housings to the differential and wheel hub.
- Mate the tripods to the standardized axles.
- Center the Inboard Tripod in its respective housing.
- Adjust the overall axle length until the outboard tripod is centered in the housing at ride height.
- Once this is done, the axle length is simply the length of the shaft.
- The additional components on the website are provided for you to build a full assembly of the axles.

Please feel free to contact us at sales@rcvperformance.com if you have any questions. NOTE: Overall axle length simply means the entire length of the axle, not the cup to cup distance or the center of CV distance to center of CV distance. Please see the of the "3D measurement" drawing for more details.

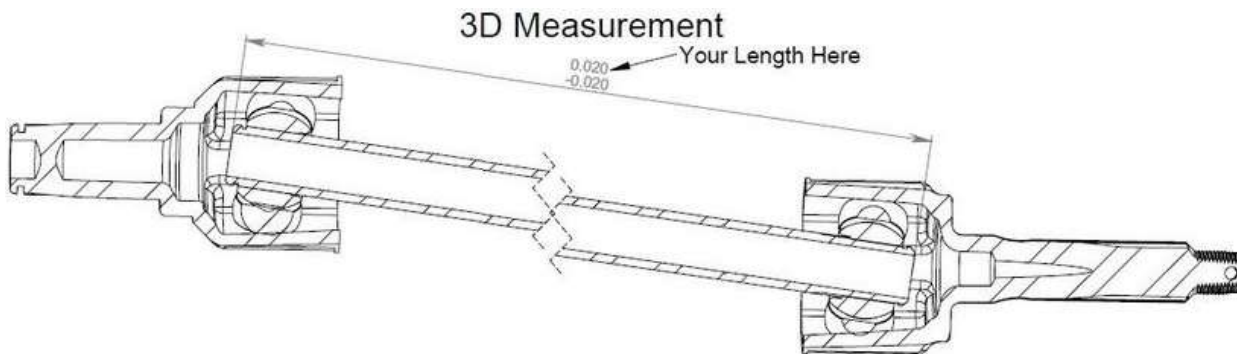

How to determine the axle length using your actual vehicle:

- First, contact us at sales@rcvperformance.com to request the tripod housings. We will send you the appropriate outer and inner tripod housings for you to get actual measurements.
- Once you have received the parts, set the car at maximum bump or the point at which the tripod housings are closest together.
- Then measure the distance between the back of the tripod housing to the back of the tripod housing minus .500".
- Send the right and left side dimensions to sales@rcvperformance.com, and we will send you the appropriate length axle. Please see the "in car" measurement drawing below.

