

NARRCO

North American Racing Rack

NARRco Rack Mk II

CONTENTS

LIST OF FIGURES AND TABLES..... 3

INTRODUCTION & ACKNOWLEDGEMENTS..... 5

SPECIFICATIONS 6

GENERAL SCHEMATICS 7

DESIGN INFORMATION 8

 Maximum Rated Load 8

 Axial Loading & Off-Axis Loading..... 9

 Tie-Rod Angle using Vertical and Longitudinal Offsets 9

 Rack Speed and Travel 9

 Rack Travel per Degree of Steering Wheel Input..... 9

 Clevis Connection to Tie-Rods..... 10

INSTALLATION & OPERATION 11

 Lubrication..... 12

 Pinion Shaft Integration 12

 Additional Notes..... 12

LIST OF FIGURES AND TABLES

Table 1: Specifications..... 7

Figure 1: Overall Dimensions 8

Figure 2: Travel Direction for Clockwise Input Rotation 8

Figure 3: Installation 9

Figure 4: Recommended Tie-Rod Connection to Clevis, Full Size Bolt (Section) 11

Figure 5: Recommended Tie-Rod Connection to Clevis, Undersized Bolt (Section)..... 11

Figure 6: Safety Wire..... 12

LIST OF SYMBOLS AND ACRONYMS

RS	Rack S peed – Linear travel per degree of wheel input
LtL	Lock to Lock – Distance rack travels from full left to full right.
CtC	Center to Center – The distance between two axes.
OAL	Off-Axis-Loading – Any force not parallel to the rack axis
TRL	Tie-Rod Length
S_{Rack}	Rack Displacement from Center
β	Steering Wheel Angle from Center
F_{TR}	Tie-Rod Load
F_x	Rack Off-Axis Load Component
F_y	Rack Axial Load Component
w/	With (Includes)
w/o	Without (Does not include)

INTRODUCTION & ACKNOWLEDGEMENTS

Thank you for making the NARRco Rack as part of your vehicle project. This product has been engineered to deliver maximum performance and weight savings at an affordable cost. To obtain the best possible performance and longevity from your NARRco please consider and implement the guidelines and recommendations presented in this document.

We appreciate any feedback, experience or opinions that will help us to continue improving the product.

We wish you speed and success in your driving endeavors!

Sincerely,

The NARRco Team

TERMS AND CONDITIONS OF SALE

OPENING THIS PACKAGE INDICATES YOUR AGREEMENT TO BE BOUND BY THE FOLLOWING TERMS AND CONDITIONS OF SALE

SHOULD YOU NOT AGREE WITH ANY PORTION OF THIS AGREEMENT, RETURN THE PRODUCT UNUSED IN ITS ORIGINAL PACKAGING ACCORDING TO INSTRUCTIONS IN SECTION 7

- 1. Orders.** All orders are subject to final acceptance by NARRCO at its principal place of business in Sugar Land, Texas. NARRCO reserves the right to cancel any uncompleted order or to suspend delivery in the event Buyer (1) becomes insolvent, files for or is the subject of any bankruptcy action, or has a receiver appointed for it; or (2) breaches any term of this agreement
- 2. Delivery and Title.** Unless otherwise noted, all goods shall be delivered F.O.B. NARRCO's Sugar Land offices and risk of loss or damage shall pass to Buyer upon NARRCO's delivery of goods to shipper or carrier for delivery. Buyer is responsible for all shipping, handling and insurance charges. Unless Buyer specifically requests a method of shipment, NARRCO shall exercise its reasonable discretion in selecting a carrier. If Buyer requests delivery via an insured and express courier such as Federal Express, Airborne or DHL, where possible, Buyer can provide NARRCO with its account number with such courier to facilitate shipment. Times quoted for shipment will be from the date of order confirmation to Buyer. Unless the parties specifically agree to the contrary, time will not be deemed of the essence in the transaction.
- 3. Taxes.** All applicable taxes, levies or duties (of whatever nature) will be paid by Buyer, or in lieu thereof, the Buyer shall provide NARRCO with a tax exemption certificate acceptable to the taxing authorities.
- 4. Payments.** Each shipment shall be considered a separate transaction and payment shall be made accordingly. In the event of default by Buyer, NARRCO may decline to make further shipments without in any way affecting its rights under other orders. Should NARRCO decide to continue to make shipments despite any default by Buyer, its action shall not constitute a waiver of such default or in any way offset or limit NARRCO's legal remedies for such default.
- 5. Limited Warranty.**
 - A. NARRCO warrants the following with respect to Product manufactured by NARRCO or bearing the NARRCO label: (1) that the Product is free from defects in material and workmanship and when used in accordance with the user manual supplied with the Product, will operate substantially in accordance with the applicable functional specifications applicable to the product purchased; and (2) that upon payment in full for the Product, they shall be rendered free and clear of liens, claims or encumbrances.
 - B. The above Product warranty shall extend to the original end user purchaser of the Product for a period of twelve (12) months from the date of shipment. With respect to any products sold but not manufactured by NARRCO or bearing the NARRCO label, NARRCO will assign to Customer all available manufacturer warranties. The warranty period for repaired or replaced Products shall be the remainder of the original warranty period for the repaired or replaced item.
 - C. NARRCO's sole liability under this warranty shall be (a) either to repair or to replace, at NARRCO's option, the defective Product component(s) in accordance with NARRCO's return and repair procedures, or (b) if after repeated efforts NARRCO is unable to resolve the defect by repair or replacement, to refund the purchase price upon return of the defective item. NARRCO shall incur no obligation under this warranty if (1) the allegedly defective Product is returned to NARRCO more than thirty (30) days after the expiration of the applicable warranty period; (2) if NARRCO's verifiable tests disclose that the alleged defect is not due to defects in material or workmanship; or (3) if, in NARRCO's sole judgment, the Product has been subjected to misuse or neglect, alteration, improper maintenance or damage due to excessive physical or heat or stress. This Product warranty is void if the serial number of the Product has been defaced, altered or removed.
- 6. Warranty Limitations and Exclusions.**
 - A. THE WARRANTIES SET FORTH ABOVE FOR THE PRODUCTS PROVIDED HEREUNDER ARE COMPLETE AND ARE IN LIEU OF, AND CUSTOMER HEREBY WAIVES, ALL OTHER CONDITIONS, REPRESENTATIONS, AND WARRANTIES, EXPRESS OR IMPLIED BY STATUTE, USAGE, CUSTOM OF THE TRADE OR OTHERWISE, INCLUDING WITHOUT LIMITATION, THE IMPLIED WARRANTIES OF MERCHANTABILITY AND FITNESS FOR A PARTICULAR PURPOSE. NOTWITHSTANDING ANY OTHER OR PRIOR STATEMENT, WRITTEN OR ORAL, NARRCO MAKES NO OTHER WARRANTIES REGARDING THE QUALITY OF ITS PRODUCT(S) OR THE MATERIALS COMTEMPLATED HEREUNDER AND NARRCO EXPRESSLY DISCLAIMS ANY WARRANTIES OF DURABILITY, THAT THE PRODUCT WILL MEET ALL OF CUSTOMER'S NEEDS OR THAT THE OPERATION OF THE PRODUCTS WILL BE ERROR FREE.
 - B. Customer acknowledges and agrees that the Products supplied under this Agreement are intended for test purposes within the confines of the Formula SAE competition, and are not specifically designed, manufactured or intended for use or resale in critical applications or hazardous environments requiring fail-safe performance and in which the failure of Products could lead directly to death, personal injury, or severe physical or environmental damage ("High Risk Activities"). NARRCO and its suppliers explicitly disclaim any express or implied warranty of fitness for any such use and the customer hereby agrees to release and hold NARRCO harmless from liability resulting out of or in connection with implementation of these Products in High Risk Activities.
 - C. LIMITATION OF LIABILITY. NARRCO'S LIABILITY SHALL BE LIMITED TO THE PRICE PAID BY CUSTOMER FOR THE GOODS OR TO REPLACEMENT OF THE GOODS, AND CUSOMTER SHALL BE ENTITLED TO NO OTHER REMEDY, REGARDLESS OF THE FORM OF THE CLAIM. NARRCO SHALL NOT BE LIABLE FOR INDIRECT, SPECIAL, INCIDENTAL, CONSEQUENTIAL OR PUNITIVE DAMAGES ARISING FROM OR RELATING TO THE USE OF OR INABILITY TO USE THE PRODUCT, WHETHER OR NOT SUCH DAMAGES ARE FORESEEABLE AND WHETHER OR NOT CUSTOMER HAS BEEN ADVISED OF THE POSSIBILITY OF SUCH DAMAGES, INCLUDING BUT NOT LIMITED TO LOST PROFITS OR REVENUE, ATTORNEYS' FEES, DAMAGE TO BUSINESS, LOSS OF USE OF EQUIPMENT, DOWN-TIME COSTS OR DAMAGES FOR DELAY, OR FOR DAMAGES FOR ECONOMIC LOSSES OR PROPERTY DAMAGE ARISING FROM ANY ACTS OR OMISSIONS, WHETHER IN NEGLIGENCE, STRICT LIABILITY, OR OTHER PRODUCT LIABILITY THEORIES. THE LIMITATIONS OF LIABILITY AND WARRANTY DISCLAIMERS STATED IN THIS AGREEMENT FORM AN ESSENTIAL BASIS OF THE BARGAIN BETWEEN THE PARTIES AND APPLY REGARDLESS OF WHETHER ANY LIMITED REMEDY HEREUNDER FAILS OF ITS ESSENTIAL PURPOSE.
- 7. Product Repair and Return Procedures.** No Product shall be returned without prior authorization from NARRCO. Inoperative or malfunctioning Product must be returned by Customer in protective material, securely packaged to prevent damage in transit with the original proof of purchase, and shipped prepaid to: NARRCO, 1918 Liberty Point Ln Sugar Land, TX 77478, USA - Phone: (785) 979-0679
NARRCO will return repaired/replaced Product via surface freight to Customer's location. The cost of expedited freight, if requested, shall be at Customer's expense. Product found to be operable after testing (i.e. no trouble found), may be subject to NARRCO's then-current handling charge. Repairable out-of-warranty Product will be repaired at NARRCO's then-current repair charges upon receipt of the Product and Customer's applicable purchase order or other written authorization to repair.
- 8. Entire Agreement; Assignment.** This constitutes the entire agreement of the parties and supersedes all prior written or oral agreements, representations or understandings relating to the subject matter hereof. Buyer will not assign its order or any interest therein or any rights under this agreement without the prior written consent of NARRCO.
- 9. Force Majeure.** Neither party shall be liable for any failure or delay in performance of its obligations under this agreement where such performance is prevented or delayed by causes beyond its reasonable control, including without limitation, flood, war, embargo, strike or other labor dispute, riot, acts of God or the intervention of any government authority.
- 10. Governing Law; Disputes.** The rights and obligations of the parties arising under or in connection with the sale of NARRCO product shall be governed by the laws of the State of Texas. In the event of a dispute relating to NARRCO product, it is agreed that the parties shall first submit their dispute to mediation pursuant of the Commercial Mediation Rules of the American Arbitration Association to be held in Texas, USA within 30 days from receipt of written notice of a claim or dispute. The parties shall make a good faith attempt to resolve their dispute through mediation before seeking any other legal remedy. A party's failure to respond to a request for mediation or to attend a scheduled mediation shall entitle the other party to seek other legal relief.

SPECIFICATIONS

Property	NARRco Rack MkII	
Mass – Installed, w/Clevises	1.3lb	590 grams
Kinematic Length	14.4"	365.76 mm
Linear Travel Per Degree of Steering Input (13T)	.00962"	0.2443 mm
Max Linear Travel Per Side	1.25"	31.75 mm
Max Rotary Input Per Side	≤130°	
Max Axial Load Rating	1500 lbf	6670 N
Max Off-Axis Load Rating (Per Side)	210 lbf	934N
Max Deflection @ Max Travel and Max Off-Axis Load	0.042 in	1.067mm
Max Steering Torque	69 lbf-ft	93.6 Nm
Max Allowable Tie Rod Angle¹	10°	
Recommended Tie Rod Angle	0±5°	
CG Vertical Location from Rack Axis	1.75 mm (Towards Pinion Axis)	
CG Lateral Displacement Range	0±10.2 mm	
Static Friction Torque Range	< 0.9 Nm	< 8 lbf-in
Pinion Shaft Material / Hardness	AISI 4140 / 30 HRC	
Rack Material / Hardness	7075-T6 / 60 HRB	
Pitch Mass Moment of Inertia, installed @ CG ²	128761 gmm ²	
Yaw Mass Moment of Inertia, installed @CG ²	4298876 gmm ²	
Roll Mass Moment of Inertia, installed @CG ²	4319361 gmm ²	

Table 1: Specifications

[1] Note: The maximum allowable tie rod angle is specified to avoid excessive rack deflection and wear resulting in increased steering effort and reduced response. It is the responsibility of the user to determine product suitability for their unique application.

[2] Note: Mass moments of inertia indicated assuming pinion axis is horizontal, with rack parallel to vehicle pitch axis and ground plane.

GENERAL SCHEMATICS

This section outlines the main design geometry which is required for design integration purposes. Note that the effective direction of rack travel can be reversed by inverting the assembly as shown in figure “Travel Direction for Clockwise Input Rotation” below.

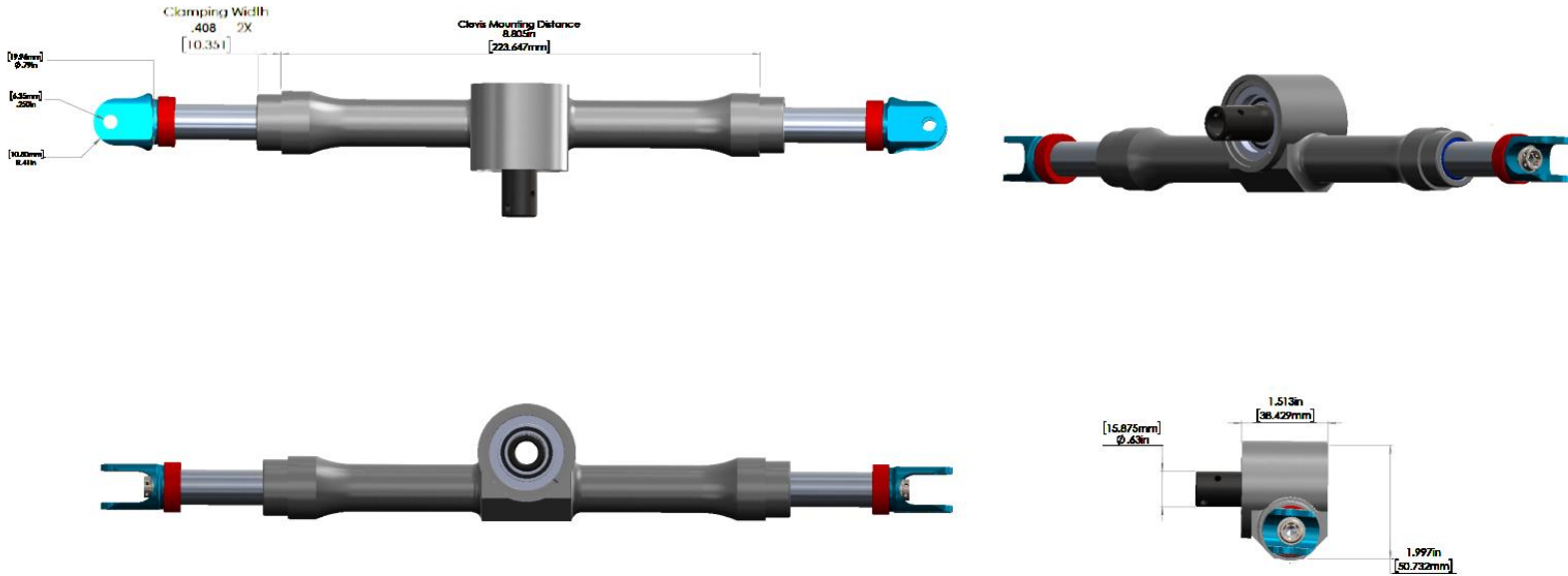

Fig 1: Overall Dimensions

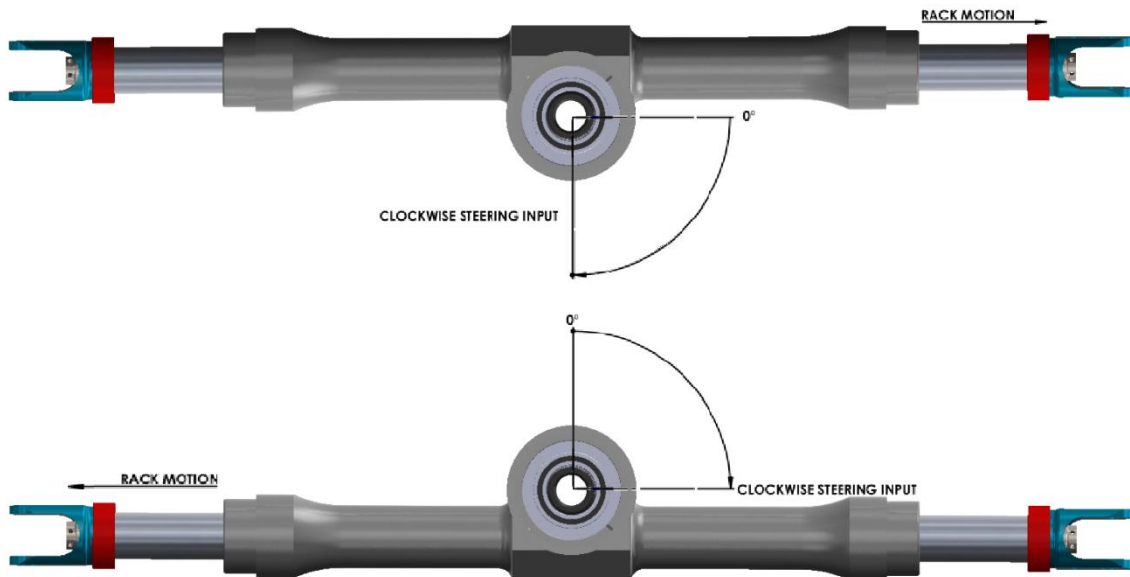

Fig 2: Travel Direction

DESIGN INFORMATION

This section is intended to provide information pertaining to the recommended installation and design integration parameters to help ensure the safe and reliable operation of the product.

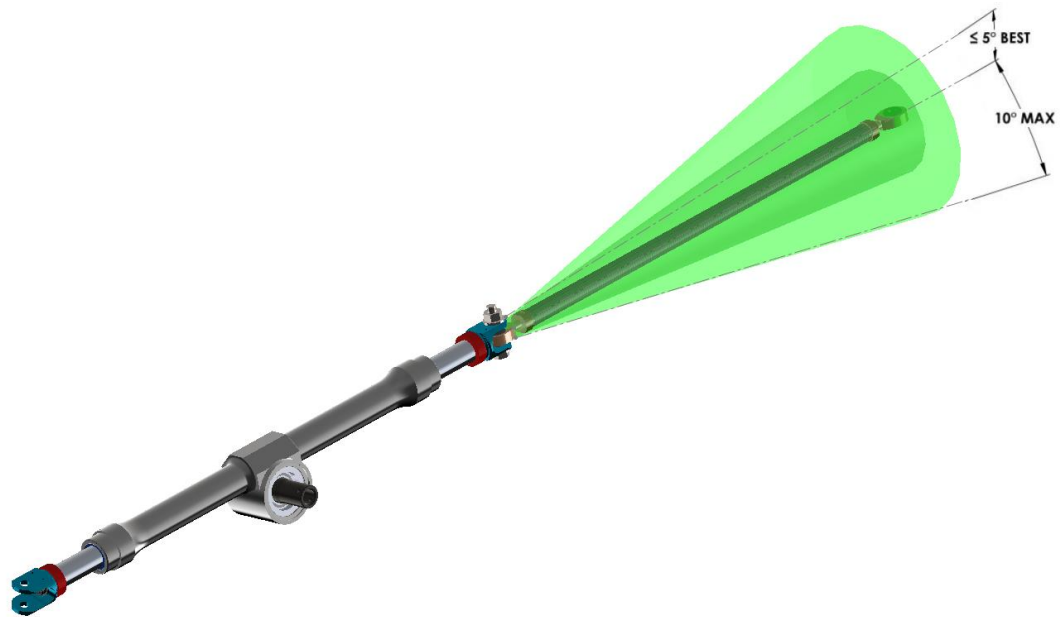

Figure 3: Installation

Maximum Rated Load

The maximum rated load is the full axial force in tension or compression which the rack is designed to withstand in service. Under normal driving conditions this load is not typically experienced except in cases of collision involving the front wheels. The maximum rated load corresponds to the maximum force the driver of a smaller-scale racecar could resist before the steering is torn from their grip. Typical driver posture and position make it nearly impossible to exert this maximum load on the steering system. **Furthermore, it is of critical that any driver be instructed and trained to release their grip from the steering wheel in cases of imminent collision to reduce the risk of serious injury.** For the purposes of load matching the maximum rated load (6670 N) can be used to design related steering components. The recommended maximum operating load for the NARRco Rack is 1780N; which is a typical value for gross vehicle weight of less than 400kg, and non-impact events. Please note that these values are for

reference only and may not apply to or be optimized for every application. The end-user must verify design loads, factors of safety and possible failure modes for all associated components are appropriate and do not endanger the safety of the driver in any mode of failure.

Maximum Rated Axial Load	= 6670 N	(1,500 lbf)
Recommended Design Axial Load	= 1780 N	(400 lbf)

Axial Loading & Off-Axis Loading

Differentiation exists between the recommended axial load and off-axis load. Please consider and understand the following definitions:

Axial Loading: *A force which acts parallel to and along the cylindrical axis of the rack.*

Off-Axis Loading (OAL): *Any load components applied to the rack which are not parallel to the rack axis.*

To determine the OAL the tie-rod load is separated into two components based on the angle between the tie-rod and rack axis. Note that the methods below assume that the rack axis is perpendicular to the vehicle longitudinal centerline and parallel to the ground plane. The loading on the rack must also be considered as the net sum of the two tie-rod loads. Consider that the maximum pinion tooth loading occurs when tie-rod forces are acting in the same direction, whereas significant axial rack loading still occurs when they are acting in opposite directions (such as under hard braking). It is also recommended to operate the rack under the minimum possible off-axis conditions; as off-axis loading has detrimental effects to the rack and pinion tooth mesh, rack bearing loads and friction, and out-of-plane mounting bulkhead loading. In extreme cases, off-axis loading will result in decreased service life, increased steering effort, perceived free-play and a larger overall turning circle radius than what might otherwise be possible.

The calculations presented here are simplified and for reference only. It is recommended that final design calculations be based on vector representations for all forces and moments and be conducted throughout the full spectrum of the suspension and steering travel under all driving conditions.

THE MAXIMUM ALLOWABLE TIE-ROD ANGLE IS 10°... 0±5° IS RECOMMENDED.

Rack Speed and Travel

The linear travel of the rack is constant and proportional to the rotary steering input angle. The ratio has been chosen based on team feedback to be compatible with competitive entries in the Formula SAE / STUDENT classes. The term 'Rack Speed' is commonly used to compare the ratio of rack linear travel per full turn of the steering wheel (360°).

RACK SPEED = 87.88 mm / Revolution, Constant.

Rack Travel per Degree of Steering Wheel Input

Steering Input Angle	β	$(-130^\circ \leq \beta \leq 130^\circ)$
Rack Position	$S_{Rack} = \beta \times \frac{87.88 \text{ mm}}{360^\circ}$	$(-31.75 \text{ mm} \leq S_{Rack} \leq 31.75 \text{ mm})$

Clevis Connection to Tie-Rods

Tie-rod clevises which are compatible with standard spherical rod end connectors ranging in size M4-M6 (#8-¼ in). The clevis pin bore diameter is 6.35mm (0.25 in), and in cases where smaller diameter pins or bolts are desired it is necessary to manufacture spacers with stepped bosses to account for the difference in size.

Spacers which have stepped bosses should be designed such that the top of the boss does not extend beyond the outer faces of the clevis; otherwise the clamping force of the clevis bolt will not be applied equally to the clevis and spacer/rod-end stack. Boss tolerances should create a transitional fit (H9/n6).

Use high quality fasteners to make the connection between the tie-rod spherical ball joints and the clevises. It is recommended to use partially threaded fasteners which are not threaded in the shear zones between the clevis forks, spacers, and the tie-rod ball.

RECOMMENDED TIE-ROD CONNECTION BOLTS: AN4-10A

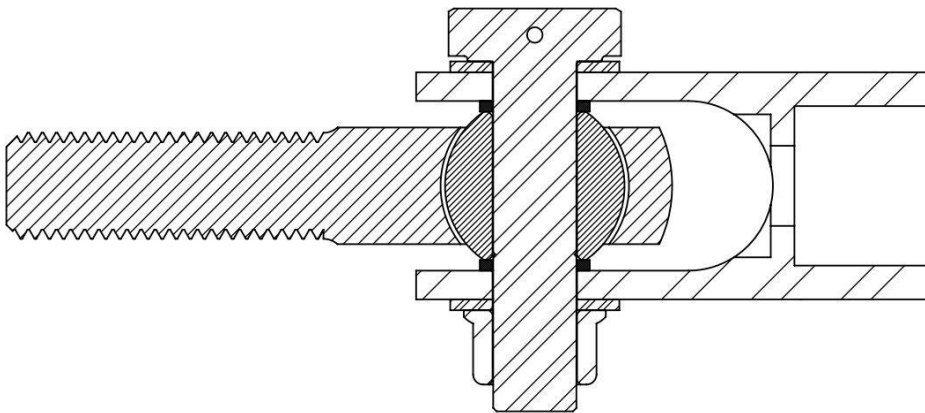

Figure 4 Recommended Tie-Rod Connection to Clevis, Full Size Bolt (Section)

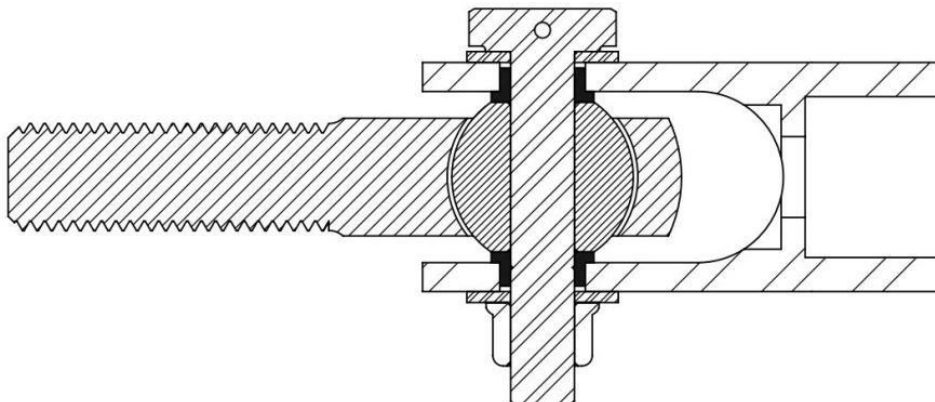

Figure 5: Recommended Tie-Rod Connection to Clevis, Undersized Bolt (Section)

INSTALLATION & OPERATION

The NARRco has been engineered to operate reliably when properly installed and maintained. It is important to understand and follow all specifications and recommendations listed below to ensure proper operation.

Mounting Blocks

Mounting Clamps can be purchased from FSAE Parts. A reference design drawing has also been provided so that clamps may be custom-manufactured.

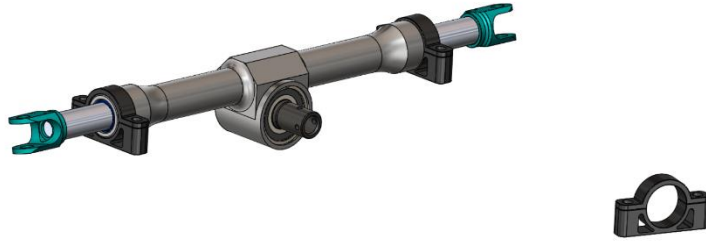

Figure 6: Rack with Mounting Blocks

Hardware

The Grade 8.8 Clevis Retaining bolts must be installed (by the user) with medium strength LOCTITE® 242™ Threadlocker. All hardware must also be torqued to the specified torque settings listed below:

Clevis Screw:	6.7 Nm	(60 lbf-in)
---------------	--------	-------------

Clevis retaining screws must be safety wired to prevent loosening, as shown below:

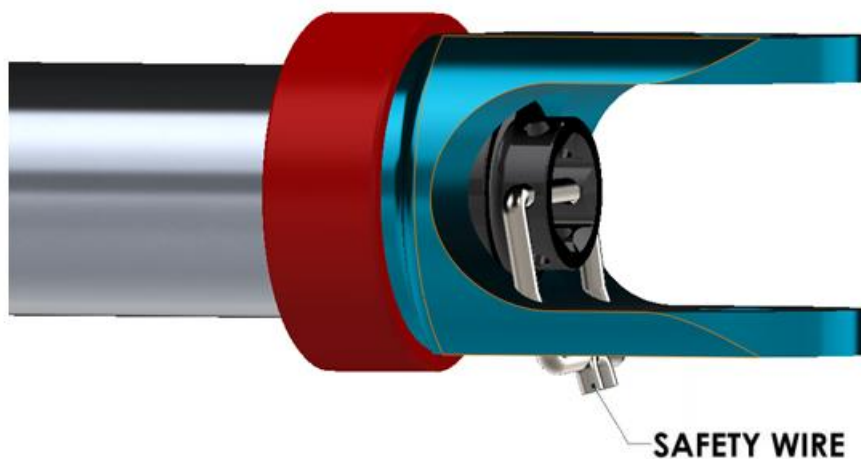

Figure 7: Safety Wire

Lubrication

The rack comes pre-lubricated with Mobil 1™ rack lube (Mobilith SHC 1500) and does not require any routine maintenance. The exposed areas of the rack may be cleaned and re-lubricated by applying a thin layer of rack lube, as necessary. Disassembly should be avoided to ensure proper operation and maximum service life.

Pinion Shaft Connection

The pinion shaft connection is non-removable and has been designed to take two $\varnothing \frac{1}{8}$ " Heavy Duty Steel Coiled spring pin connections (Note: We recommend safety wiring these pin connections)



Figure 8: Heavy Duty Steel Coiled Spring Pin

- The OD of the connection of the pinion shaft is $\varnothing \frac{5}{8}$ "

END-USERS MUST VERIFY THE SUITABILITY OF ANY MODIFICATIONS AND/OR ATTACHMENTS MADE TO THE PINION SHAFT (OR ANY OTHER PART PROVIDED) AND ACCEPT RESPONSIBILITY FOR ANY DAMAGE AND LOSS OF PERFORMANCE OR SAFETY.



Figure 9 Pinion shaft attachment example

The pinion shaft may be attached to the steering shaft by various methods:

1) Direct

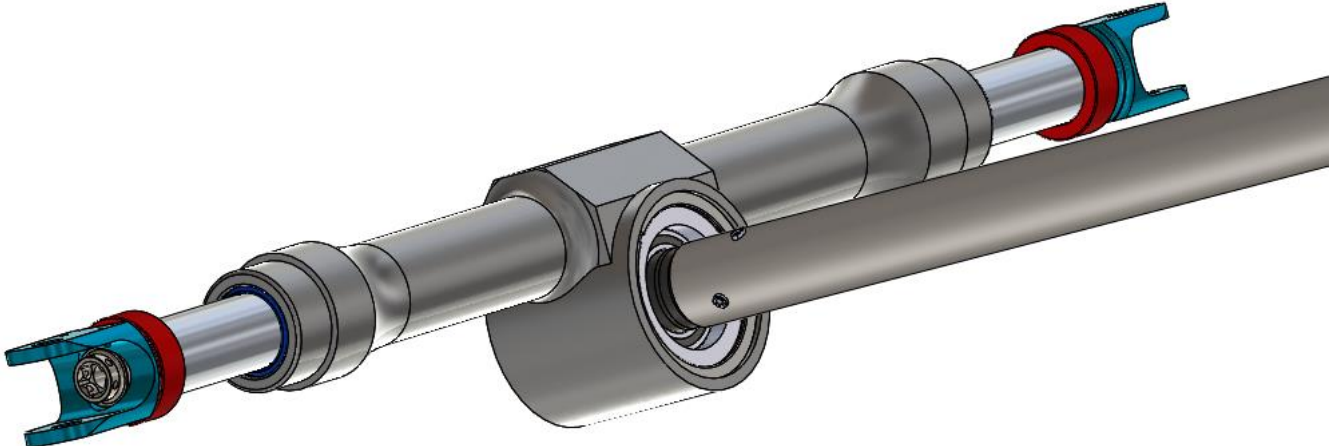

2) Welded

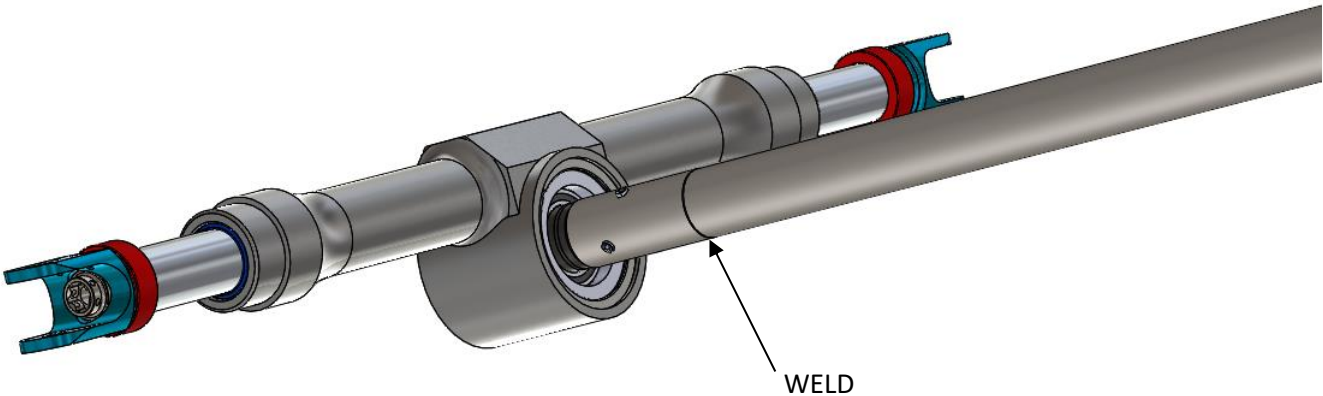

3) Bonding

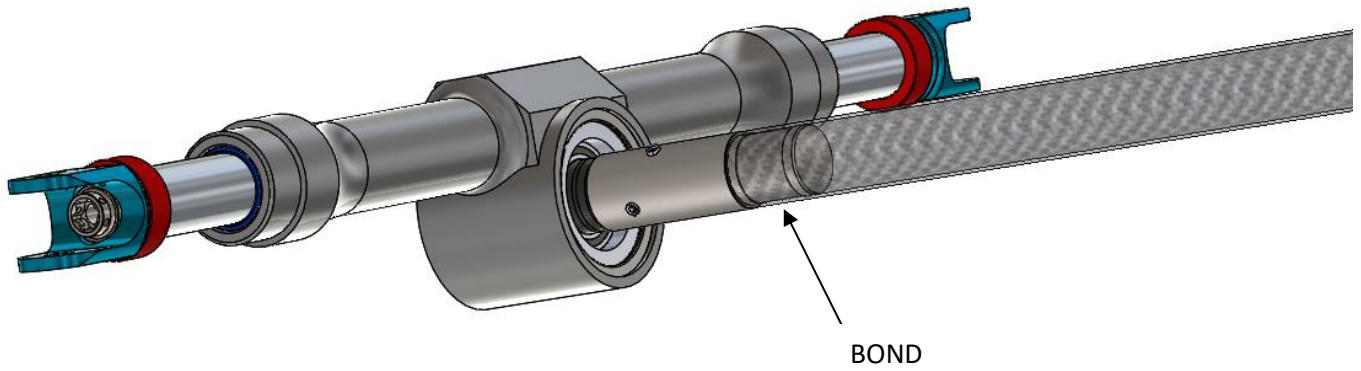

Additional Notes

The NARRco Rack assembly must not be used as a structural frame member.

The NARRco Rack should be protected from excessive heat. Do not attempt to weld on the assembly or any of the components.

Disassembling the NARRco Rack is not recommended.

Reference Design Drawings

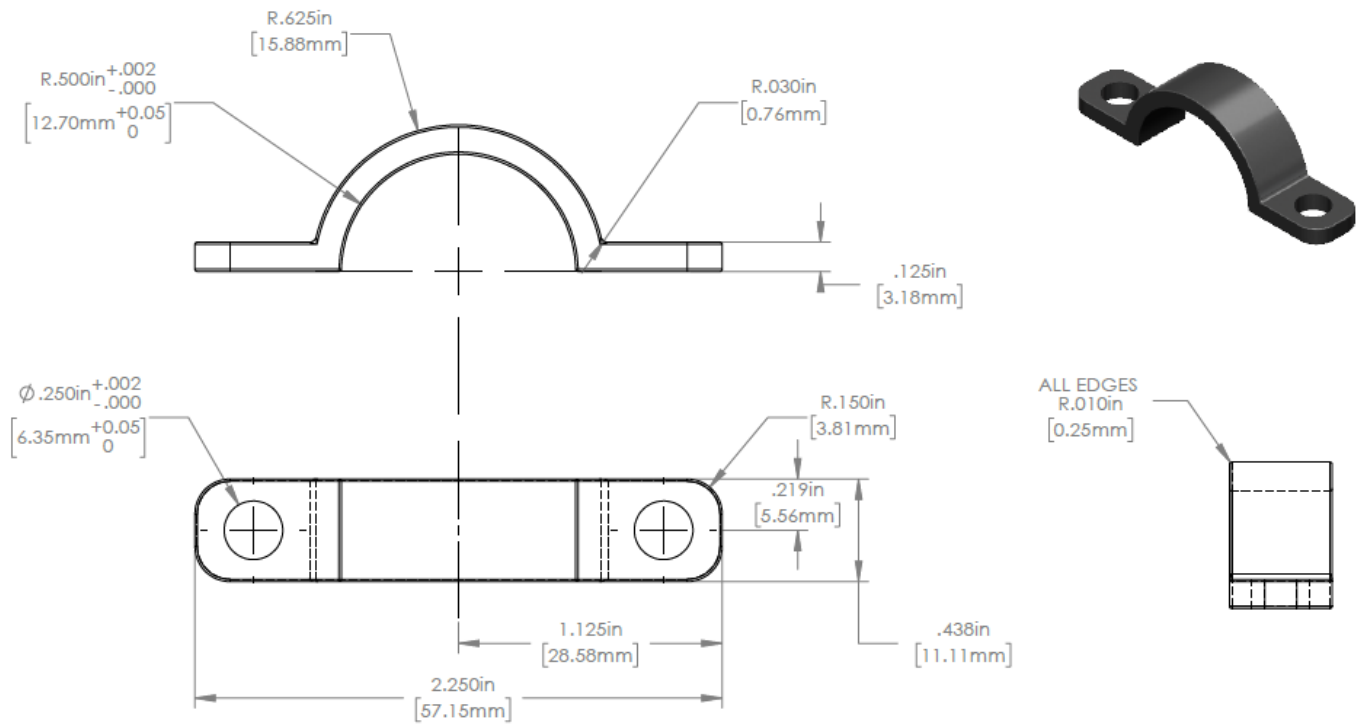

Figure 10 Upper Rack Mount

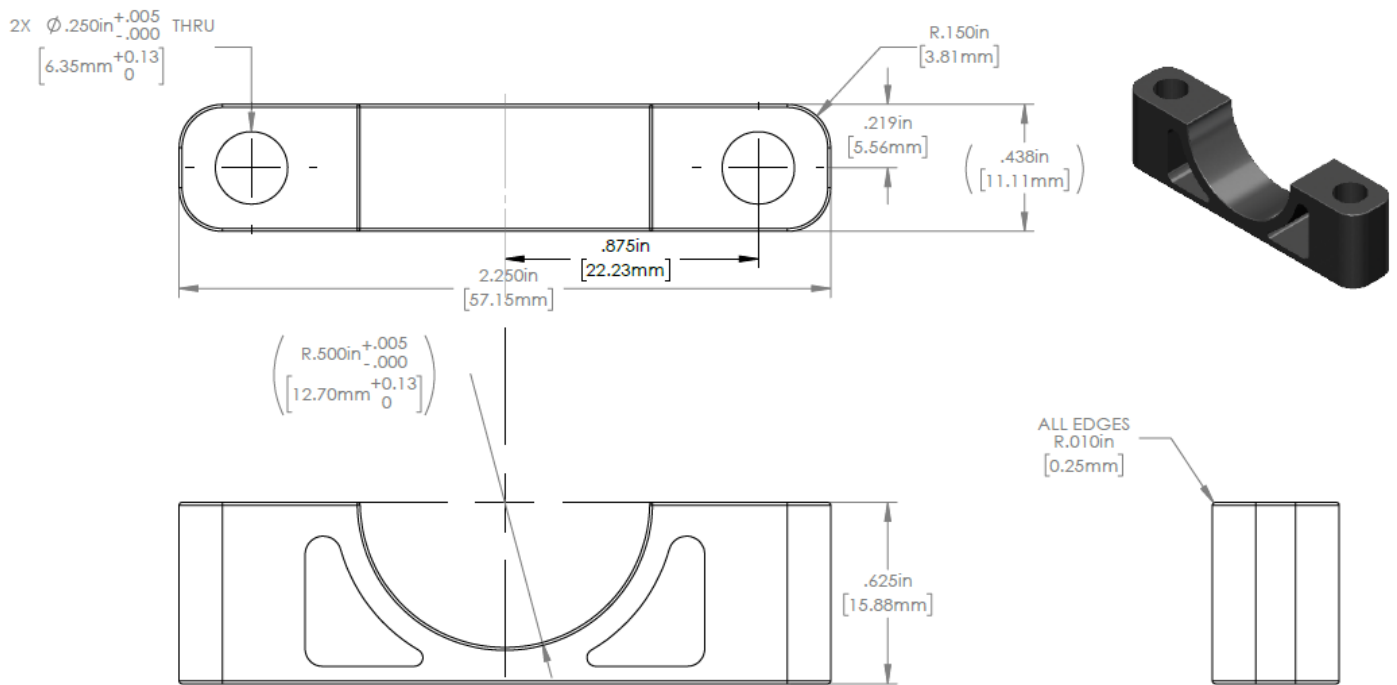

Figure 11 Lower Rack Mount

NARRCO

North American Racing Rack

NARRco Rack Mk II Installation and Operation Guide