

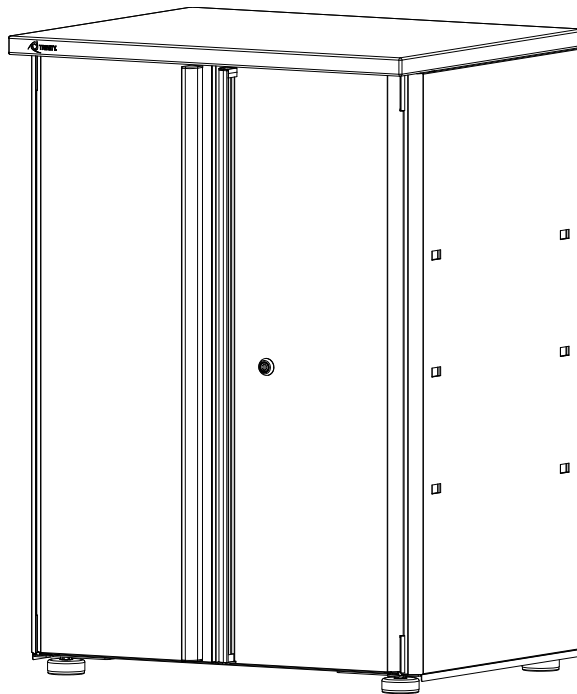

OWNER'S MANUAL



**TRINITY 24" Garage Base Cabinet
Model # TLSPBK-0603**

PARTS LIST

Your TRINITY 24" Garage Base Cabinet should include the following parts. Please inspect box contents to ensure you have received all components.

If you are missing any parts, need assistance with assembly or have questions, please contact TRINITY Customer Service: 800.985.5506 or customerservice@trinityii.com. Parts can also be requested online at www.trinityii.com (Help & More, Contact Us).

You will need a Phillips screwdriver for assembly which is not provided.

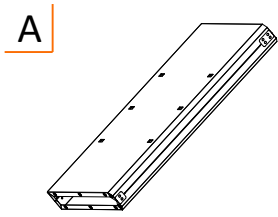

A
CABINET BODY (1)

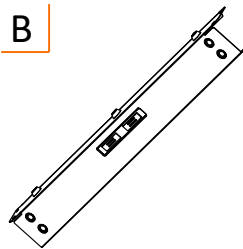

B
TOP BEAM (1)

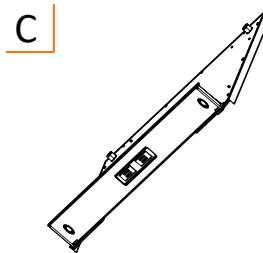

C
BOTTOM PANEL (1)

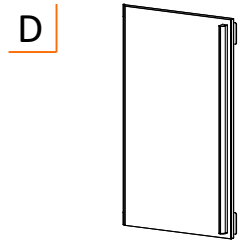

D
LEFT DOOR (1)

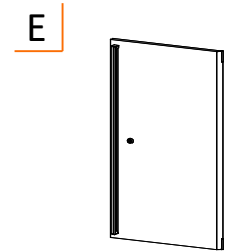

E
RIGHT DOOR (1)

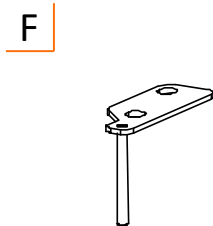

F
LEFT DOOR HINGE (1)

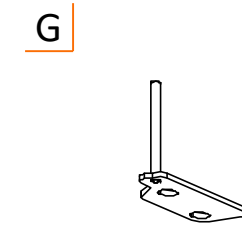

G
RIGHT DOOR HINGE (1)

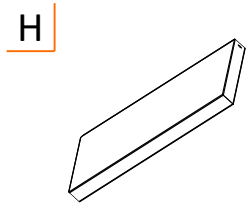

H
SHELF (1)

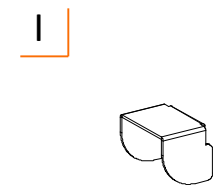

I
SHELF SUPPORT (4)

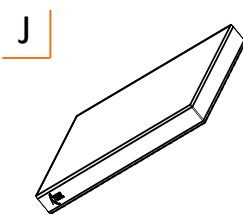

J
WOOD TOP (1)

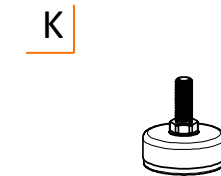

K
FEET LEVELER (4)

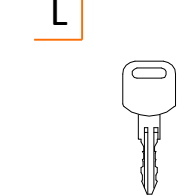

L
KEY (2)



M
BLACK SCREW
(22) + (2) extra



N
SILVER SCREW
(13) + (2) extra

ASSEMBLY INSTRUCTIONS

STEP 1

Unfold CABINET BODY (A).

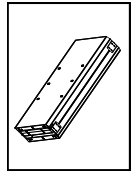
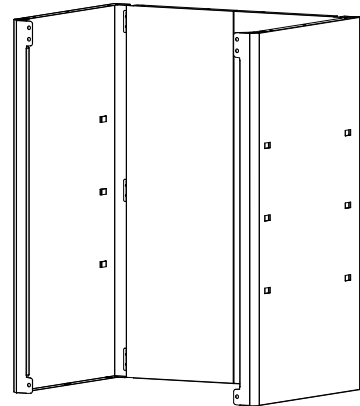
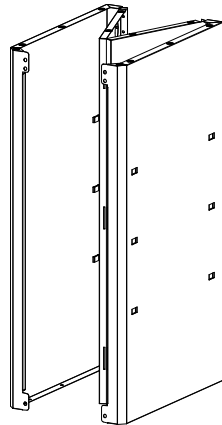

A (1)

STEP 2

Two people are recommended for ease of assembly. Stand the unfolded CABINET BODY (A) upside down on the floor.

Note: There is a 40mm diameter hole on the back panel of the CABINET BODY (A). When the CABINET BODY (A) is upside down, this hole should be in the upper left corner of the back panel.

Turn BOTTOM PANEL (C) upside down. Tilt the front diagonally downward. First, insert the lip into the inner side of the tab of CABINET BODY (A) at the right side, then insert into the left side.

Follow the order indicated, insert (12) BLACK SCREWS (M) through holes on BOTTOM PANEL (C) and tighten them fully with a Phillips screwdriver to CABINET BODY (A). Insert (2) BLACK SCREWS (M) through the tabs on front of CABINET BODY (A) and tighten them fully to BOTTOM PANEL (C).

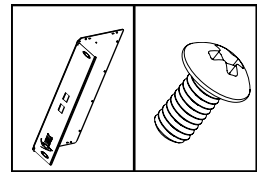

C (1)

M (14)

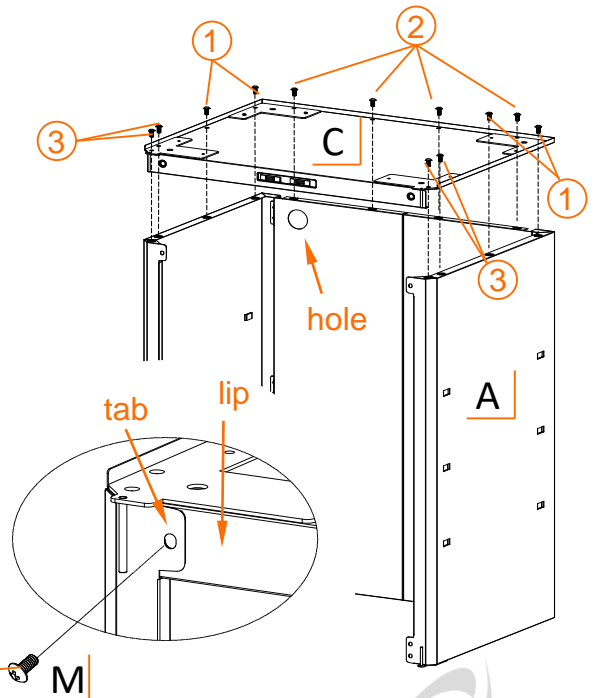

ASSEMBLY INSTRUCTIONS

STEP 3

Screw FEET LEVELER (K) all the way in each pre-installed nut in four corners of the BOTTOM PANEL(C).

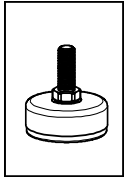
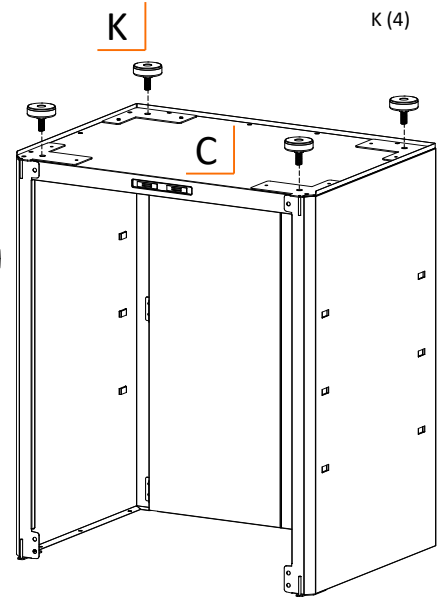
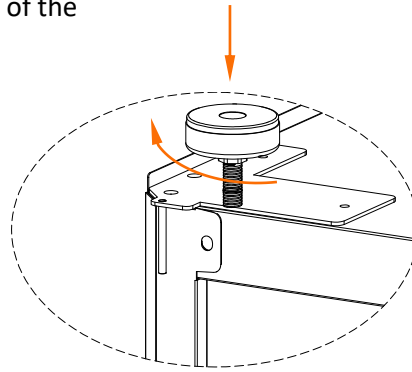

K (4)

STEP 4

Stand the unit right side up.

Position TOP BEAM (B) on top front of the cabinet. Make sure the lip of TOP BEAM (B) is inside the tabs. Align the holes on tabs to pre-installed nuts on lip of TOP BEAM (B). Insert BLACK SCREWS (M) through these holes. Tighten them fully with a Phillips screwdriver.

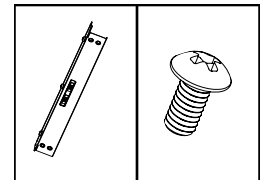
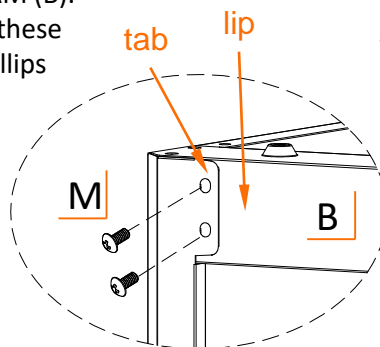

B (1)

M (4)

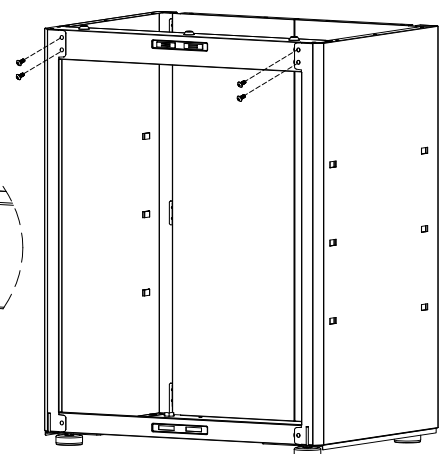

ASSEMBLY INSTRUCTIONS

STEP 5

Note: RIGHT DOOR (E) has a lock on it.

Attach LEFT DOOR (D) and RIGHT DOOR (E) one at a time to the cabinet front by inserting the pivot of door hinge which is welded on the BOTTOM PANEL(C) into the bottom door cylinder.

Position LEFT DOOR HINGE (F) to the left side of TOP BEAM (B) and RIGHT DOOR HINGE (G) to the right side of TOP BEAM(B). Make sure to insert the pivots of DOOR HINGES (F+G) into the top door cylinders. Align holes on DOOR HINGES (F+G) to pre-installed nuts on two sides of TOP BEAM (B). Insert BLACK SCREWS (M) through these holes. Tighten them fully with a Phillips screwdriver.

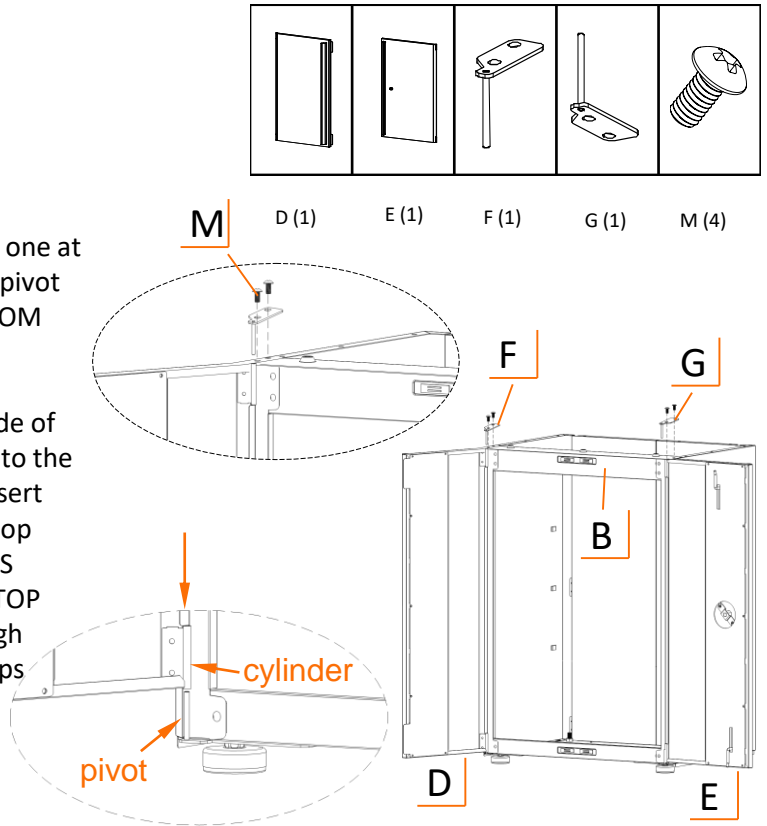

STEP 6

Lay WOOD TOP (J) gently on a clean surface. Make sure the side with a rectangular groove faces up.

Turn the cabinet upside down and put it on the WOOD TOP (J). Make sure the TOP BEAM (B) sit inside the groove. Align holes on TOP BEAM (B) and the top frame of cabinet to pre-installed nuts on wood top. Follow the order indicated, insert SILVER SCREWS (N) through these holes and tighten them fully with a Phillips screwdriver.

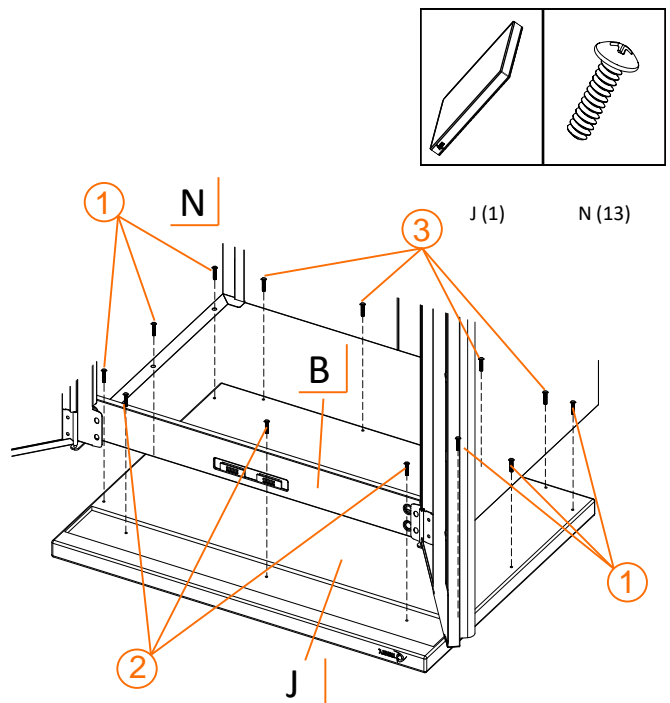

ASSEMBLY INSTRUCTIONS

STEP 7

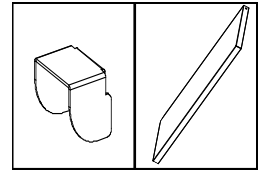

I (4)

H (1)

Stand the unit right side up.

Attach SHELF SUPPORT (I) by hooking it over the position tab at your desired height. Make sure all four SHELF SUPPORTS (I) are at the same level.

Tilt SHELF (H) diagonally to move it inside the cabinet. Place SHELF (H) on top of all four SHELF SUPPORTS (I).

Adjust FEET LEVELERS (K) as needed to ensure your cabinet is level and stable.

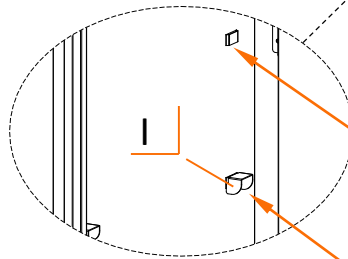
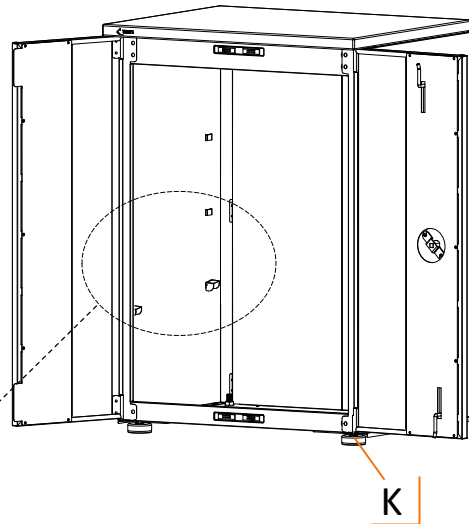

position tab

shelf support hooked on position tab

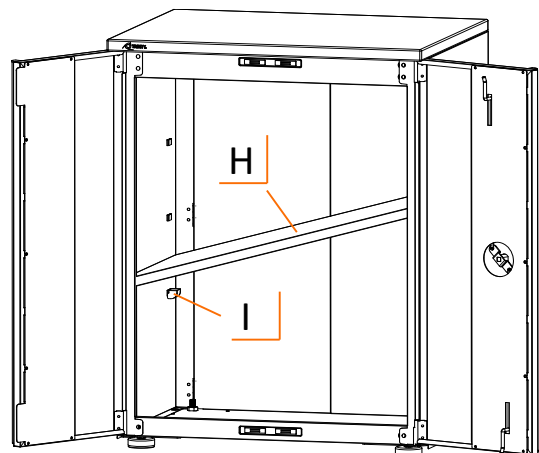

USAGE INSTRUCTIONS

SHELF ADJUSTMENT

Ensure all products have been removed from the shelf.

To adjust the shelf height position, take the shelf out of the cabinet, re-attach the shelf supports to the position tabs at your desired height.

Tilt the shelf diagonally to move it inside the cabinet. Place the shelf on top of all four shelf supports.

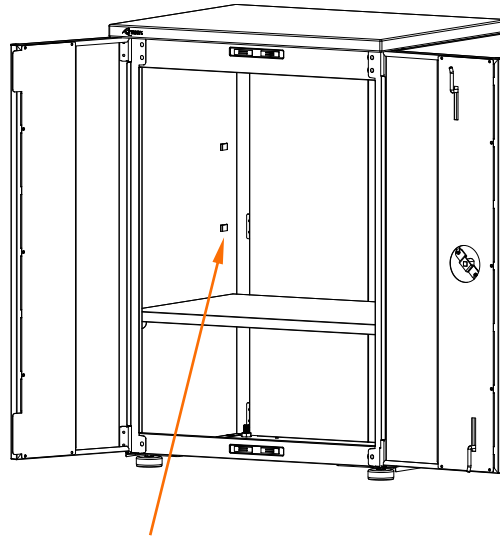

position tab

LOCK AND UNLOCK

Insert the key into the lock on the right door. Turn it clockwise 90 degree to lock the door. Turn it counter-clockwise 90 degree to unlock the door.

Before locking the unit, make sure the doors are fully closed.

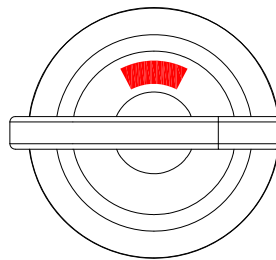

Red indicates locked

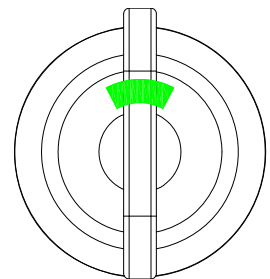

Green indicates unlocked

SERVICE PARTS LIST – TLSPBK-0603

TRINITY Customer Service provides the following replacement parts:

Part Number	Description	Part Number	Description
1) LNA-06-011-2419	Wood Top	9) PBK-16-003-2418	Bottom Panel
2) PBK-18-018-2418	Cabinet Body	10) XWH-98-001-4264	Feet Leveler
3) PBK-09-011-0001	Right Door Hinge	11) PBK-08-007-1132	Left Door
4) PBK-08-006-1132	Right Door	12) AMA-05-019-3150	Door Handle
5) XBK-10-001-0XXX	Key	13) PBK-13-010-2370	Top Beam
6) PBK-03-052-2416	Shelf	14) PBK-09-012-0001	Left Door Hinge
7) XSV-02-017-0001	Shelf Support	15) XBK-01-004-0612	Black Screw
8) XBK-02-001-0003	Magnetic Catch	16) ZSV-01-004-0415	Silver Screw

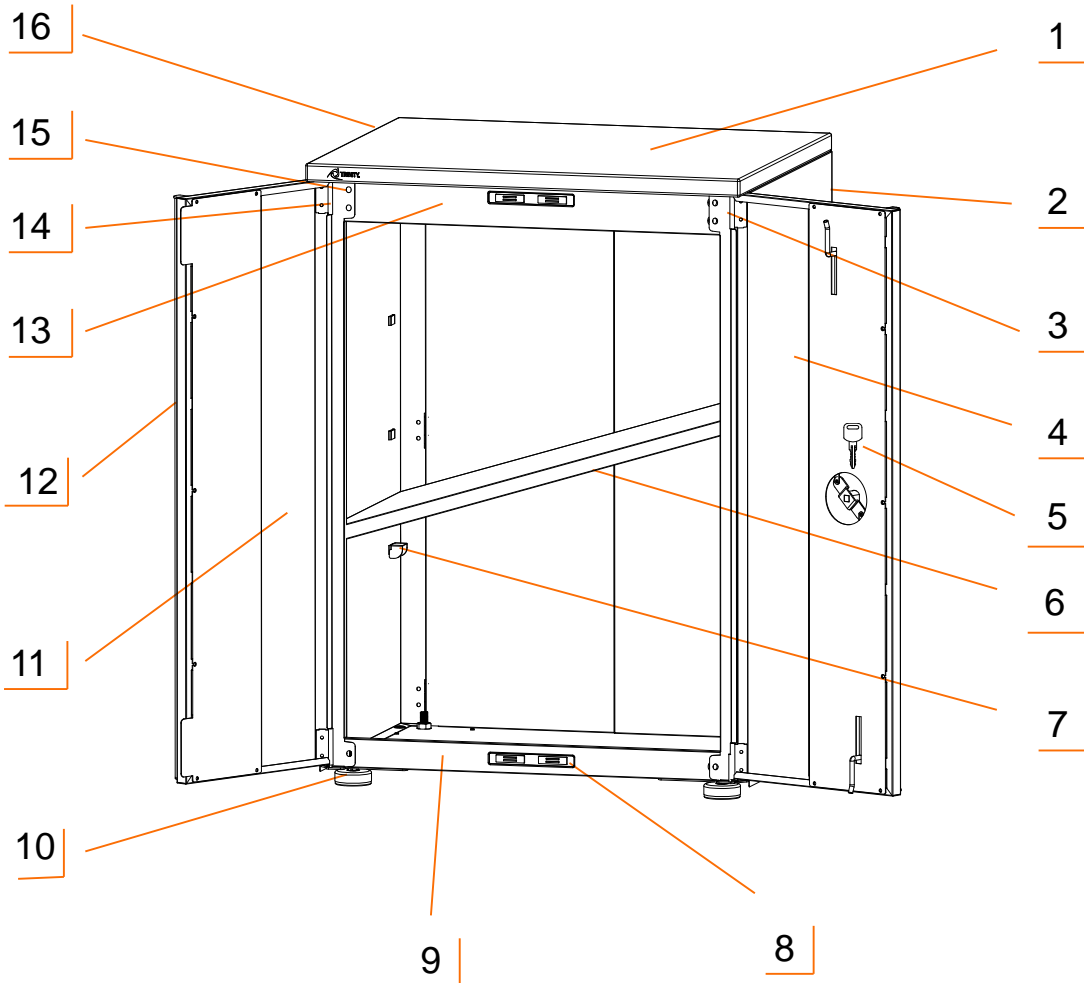

WARNINGS

- 1. Read and understand all instructions.** Failure to follow all instructions may result in injury and/or damage.
- 2. The warnings, cautions, and instructions discussed in this manual cannot cover all possible conditions or situations that may occur.** The user must always be aware of their environment and ensure that they use the product in a safe and responsible manner.
- 3. Do NOT modify the product in any way.** Unauthorized modification may impair the function and/or safety of the product, and may affect the life of the product.
- 4. Check for damaged parts.** Before using this product, carefully check that all parts are in good condition, and that the product will operate properly and perform its intended function. Check for damaged parts and any other conditions that may affect the operation of this product. Replace damaged or worn parts, and never use this product with a damaged part.
- 5. Do NOT overload the product.**

Weight capacity of Shelf (evenly distributed)	75 lb
Total weight capacity of Cabinet (evenly distributed)	200 lb

CARE AND MAINTENANCE

- Avoid harsh, abrasive cleaners, and other corrosive chemicals.
- Do not use scouring pad for cleaning.
- This item is not certified for outdoor use.
- Wood top can be cleaned with damp cloth and wiped dry immediately with dry cloth. If needed, solvent-based wood furniture cleaner can be used.
- Clean up any spills immediately to prevent stains from forming on the wood top.

PRODUCT REGISTRATION

Thank you for purchasing a TRINITY 24" Garage Base Cabinet. In order to register your product and receive streamlined customer service, please fill out the following Product Registration Form and (1) fax the form to 310.347.4134 (2) complete the Product Registration Form online at www.trinityii.com or (3) scan and email the form to customerservice@trinityii.com. Include a copy of your original receipt with your submission.

First Name: _____ Last Name: _____

Address: _____

City: _____ State: _____ Zip Code: _____

Email Address: _____ Phone: _____

Product Model #: TLSPBK-0603 Purchase Date: ____ / ____ / ____

Location of Purchase: _____

Please rate the importance of each feature (1=least important; 10=most important)

Quality ____ Price ____ Size/Capacity ____ Appearance ____ Other ____

How did you hear about our product?

- Magazine Ad Catalog Salesperson Word of Mouth
 Internet Store Display Other

Marital Status: Single Married

Household Income: Below \$50,000 \$50,000-\$150,000 \$150,000+

Education: High School College Graduate School

Primary Residence: Own Rent

Comments/Suggestions:



1 YEAR LIMITED WARRANTY

TRINITY 24" Garage Base Cabinet Model # TLSPBK-0603

Trinity International Industries ("Trinity") warrants to the original consumer purchaser ("Purchaser") of the TRINITY 24" Garage Base Cabinet ("Product") that each Product shall be free from defects in workmanship and materials for a period of 1 year from the date of original purchase. Trinity's obligation under this warranty shall be limited to repair or replacement of, or adequate compensation for the Product which shall not be greater than the amount of the purchase price of the Product, at the option of Trinity, during the warranty period. All replaced parts and Products become the property of Trinity and must be returned to Trinity.

This warranty excludes normal wear and tear of the Product and its parts or components, and damage arising from any of the following: negligent use or misuse of the Product, use contrary to this User's Manual, or alteration by any one other than Trinity. The warranty period of 1 year shall not be extended or renewed by the repair or replacement of, or compensation for, the Product. Any warranty implied by applicable law is limited in duration to one year from the date of purchase and is subject to the same conditions and limitations as is provided for our express warranty.

Except as set forth herein, and to the extent of applicable there are no warranties on this Product either express or implied, and Trinity disclaims all warranties including, but not limited to, any implied warranties of merchantability, infringement or fitness for a particular purpose. No warranty or guarantee given by any person, firm, or corporation with respect to this product shall be binding on Trinity.

If your Product is defective or otherwise requires service or parts, please call TRINITY Customer Service toll-free at (800) 985-5506, between 8:00 a.m. and 5:00 p.m., PST. Please tell us which model you purchased, the date of the purchase, and the problem with your Product. A copy of your original purchase receipt must accompany your service request.

LIMITATION OF REMEDIES AND LIABILITY

Trinity (and its employees, officers, members, managers, affiliates and assigns) shall not be liable for any incidental, consequential, special, indirect, remote, special or punitive damages for breach of any warranty, express or implied, including, but not limited to, lost profits, lost savings, loss of anticipated benefits and attorneys' fees, which arise out of the purchase, use or inability to use the Product, whether arising out of contract, negligence, strict tort, product liability, or any other legal theory on which a claim is based. As noted above, to the extent damages are allowed by our express warranty or by applicable law, those damages may not exceed the purchase price paid for the Product. Without limiting the foregoing Purchaser assumes all risk and liability for loss, damage or injury to Purchaser and Purchaser's property and to others and their property arising out of the use, misuse, or inability to use this Product. This limited warranty shall not extend to anyone other than the original purchaser of this product, is nontransferable and states your exclusive remedy.

Some states do not allow the exclusion or limitation of incidental, consequential, special, or punitive damages, so the above limitation or exclusion may not apply to you. The above warranty gives you specific legal rights, and you may have other rights which vary from state to state.

CONTACT US

**QUESTIONS? NEED PARTS?
WE ARE HERE TO HELP!**

Please feel free to contact us. There are no questions too small, or any problems too big. We're committed to providing our customers with the highest level of service.

TRINITY Customer Service

TEL: 800.985.5506

FAX: 310.347.4134

EMAIL: customerservice@trinityii.com

**Monday through Friday
5:00 AM – 5:00 PM (PST)**

www.trinityii.com



OWNER'S MANUAL

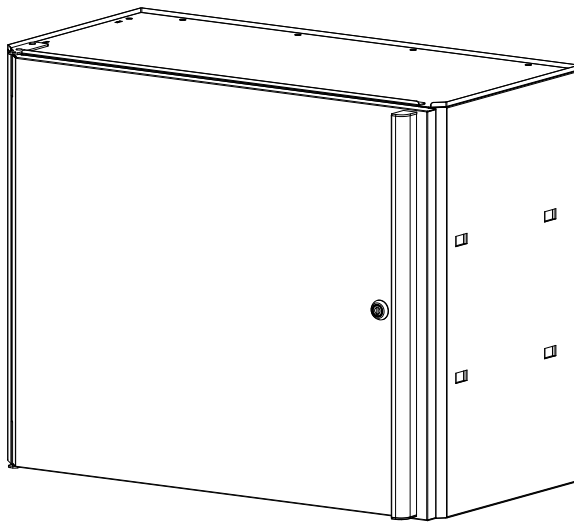

**TRINITY 24" Garage Wall Cabinet
Model # TLSPBK-0604**

PARTS LIST

Your TRINITY 24" Garage Wall Cabinet should include the following parts. Please inspect box contents to ensure you have received all components.

If you are missing any parts, need assistance with assembly or have questions, please contact TRINITY Customer Service: 800.985.5506 or customerservice@trinityii.com. Parts can also be requested online at www.trinityii.com (Help & More, Contact Us).

You will need a Phillips screwdriver for assembly which is not provided.

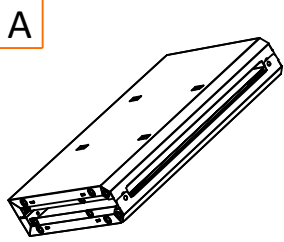

A
CABINET BODY (1)

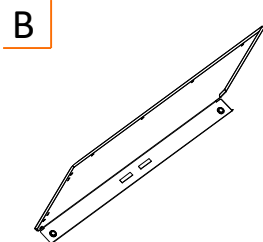

B
TOP PANEL (1)

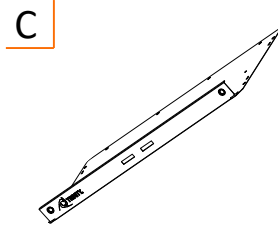

C
BOTTOM PANEL (1)

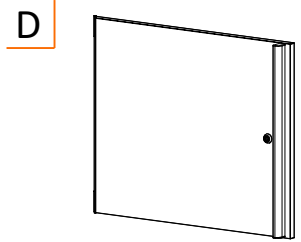

D
DOOR (1)

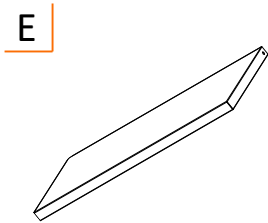

E
SHELF (1)

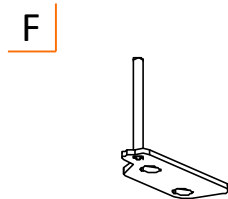

F
DOOR HINGE-F (1)

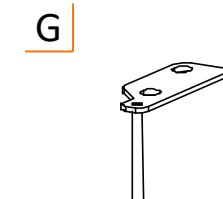

G
DOOR HINGE-G (1)

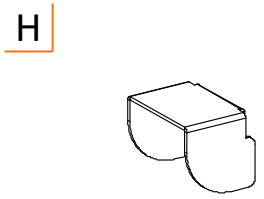

H
SHELF SUPPORT (4)

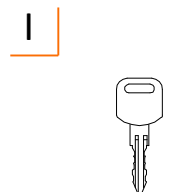

I
KEY (2)



J
**BLACK SCREW
(24) + (2) extra**

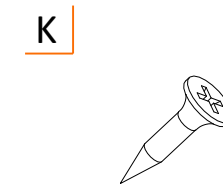

K
MOUNTING SCREW (4)

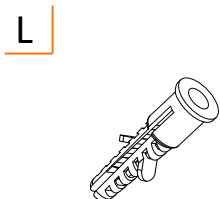

L
ANCHOR (4)

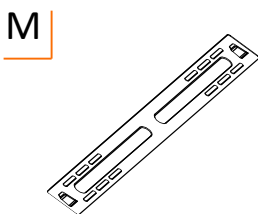

M
WALL BRACKET (1)

ASSEMBLY INSTRUCTIONS

STEP 1

Unfold CABINET BODY (A).

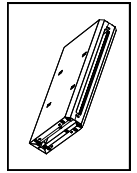

A (1)

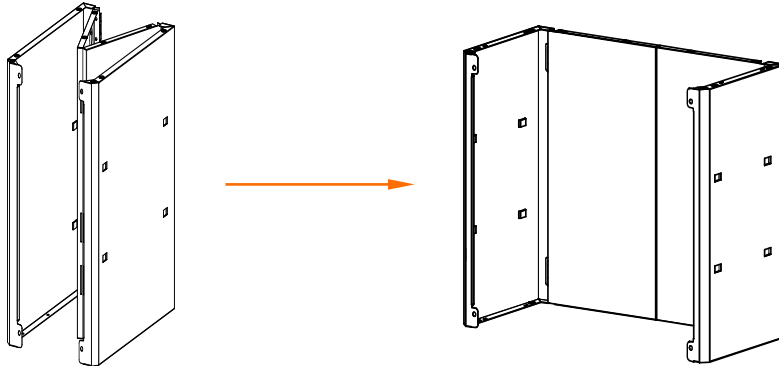

STEP 2

Two people are recommended for ease of assembly. Stand the unfolded CABINET BODY (A) upside down on the floor.

Note: There is a 40mm diameter hole on the back panel of the CABINET BODY (A). When the CABINET BODY (A) is upside down, this hole should be in the upper left corner of the back panel.

Turn BOTTOM PANEL (C) upside down. Tilt the front diagonally downward. First, insert the lip into the inner side of the tab of CABINET BODY (A) at the right side, then insert into the left side.

Note: Do not install screws in the two holes at the right or left front corners of BOTTOM PANEL (C) until instructed.

Follow the order indicated, insert (6) BLACK SCREWS (J) through the hole on each back corner and four holes on the back side of BOTTOM PANEL (C). Tighten them fully with a Phillips screwdriver. Insert (2) BLACK SCREWS (J) through the tabs on front of CABINET BODY (A) and tighten them fully to BOTTOM PANEL (C).

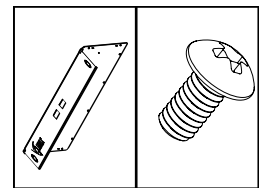

C (1)

J (8)

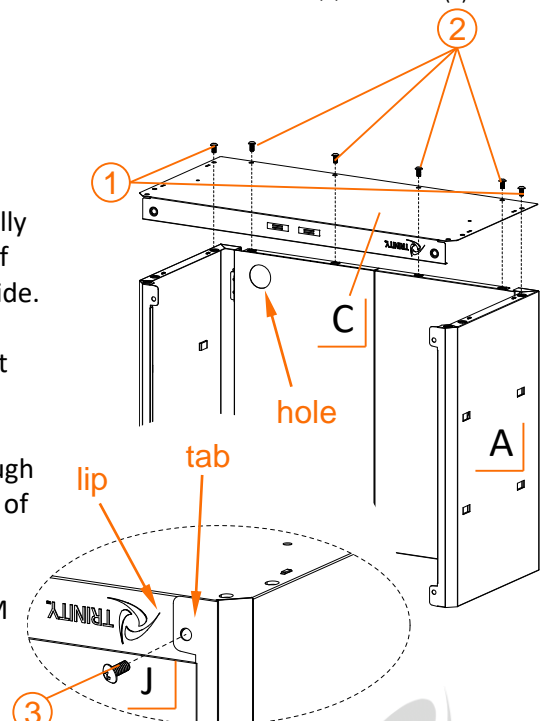

ASSEMBLY INSTRUCTIONS

STEP 3

DOOR (D) can be installed on the left **OR** right side of the cabinet. Only install one hinge in this step.

RIGHT INSTALLATION:

Position DOOR HINGE-G (G) on the left front corner of the outside of BOTTOM PANEL (C) and align the holes. Make sure the pivot of hinge faces down.

LEFT INSTALLATION:

Position DOOR HINGE-F (F) on the right front corner of the outside of BOTTOM PANEL (C) and align the holes. Make sure the pivot of hinge faces down.

Insert (2) BLACK SCREWS (J) through the DOOR HINGE (F or G) and (2) through BOTTOM PANEL (C). Tighten fully with a Phillips screwdriver.

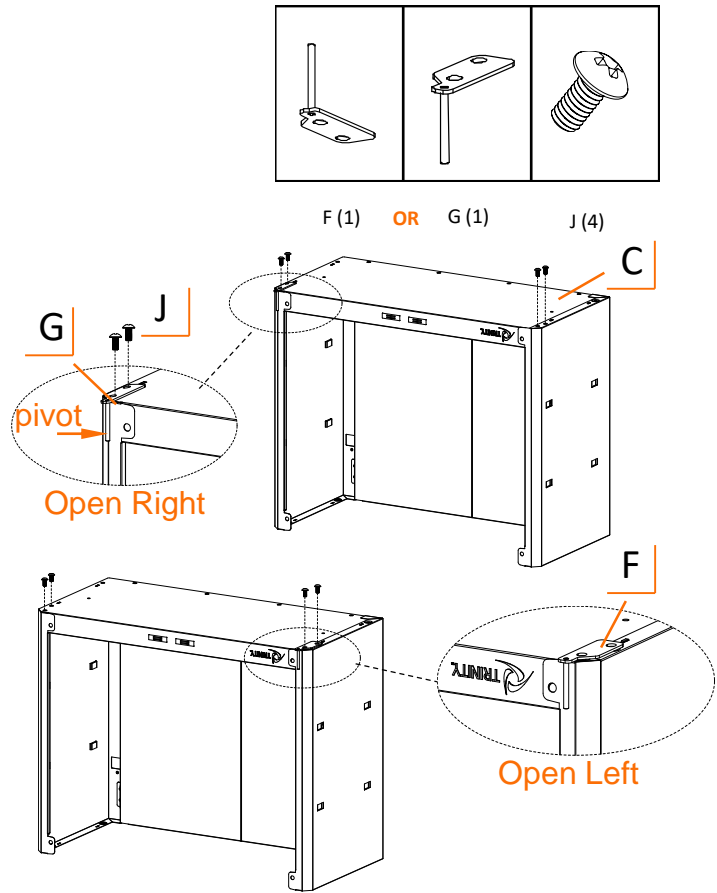

STEP 4

Stand the unit right side up.

Tilt front of TOP PANEL (B) diagonally downward. First, insert the lip into the inner side of the tab of CABINET BODY (A) at the right side, then insert into the left side.

Note: Do not install screws in the two holes at the right or left front corners of TOP PANEL (B) until instructed.

Follow the order indicated, insert (6) BLACK SCREWS (J) through the hole on each back corner and four holes on the back side of TOP PANEL (B). Tighten them fully with a Phillips screwdriver. Insert (2) SCREWS (J) through the tabs on front of CABINET BODY (A) and tighten them fully to TOP PANEL (B).

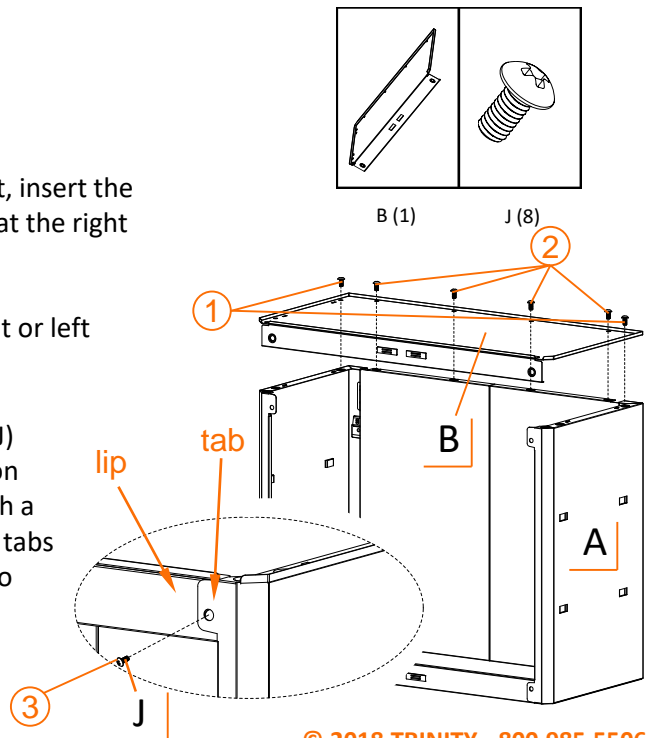

ASSEMBLY INSTRUCTIONS

STEP 5

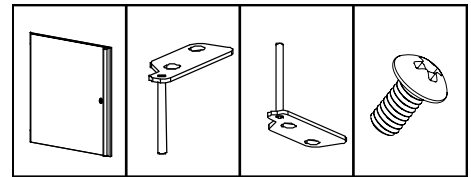

D (1) G (1) OR F (1) J (4)

Attach DOOR (D) to the cabinet front by sliding the bottom door cylinder over the DOOR HINGE (F or G) installed in Step 3.

Position remaining DOOR HINGE (G or F) to the left or right front corner of TOP PANEL (B). Make sure to insert the pivot of DOOR HINGE into the top door cylinder first.

Align holes on DOOR HINGE (G or F) to pre-installed nuts on frame of CABINET BODY (A). Insert (2) BLACK SCREWS (J) through the DOOR HINGE (G or F) and (2) through TOP PANEL (B). Tighten fully with a Phillips screwdriver.

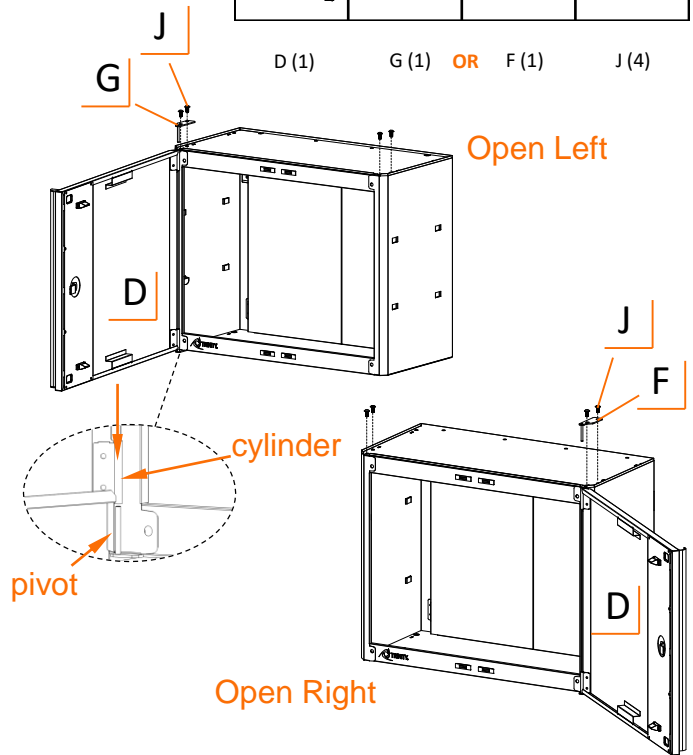

STEP 6

Position WALL BRACKET (M) on the wall at the desired height.

If needed, use a pencil to mark off the mounting location on the wall through one of the oval holes on each end of WALL BRACKET (M). Drill holes in marked locations. Insert ANCHOR (L) completely into each drilled hole.

Fasten SCREWS (K) through the oval holes on WALL BRACKET (M) into the wall or anchors tightly with a Phillips screwdriver.

Note: Please consult a local contractor if you are unsure if your wall is able to bear the load of the wall cabinet.

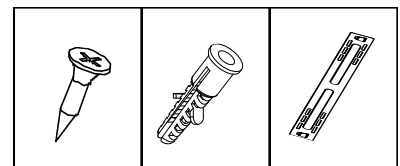

K (2) L (2) M (1)

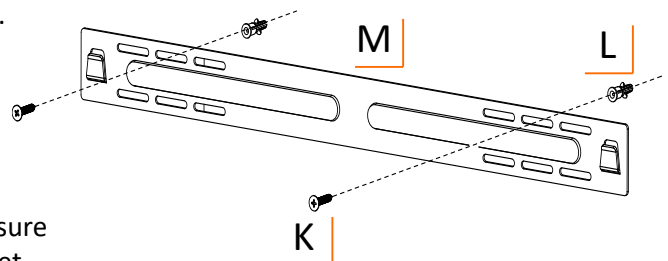

ASSEMBLY INSTRUCTIONS

STEP 7

Lift the cabinet and hang it carefully on two hooks of WALL BRACKET(M) through two square holes on the back side of cabinet. Two people are needed, DO NOT attempt this alone.

There are two small round holes on the back side of cabinet. Use a pencil to mark off the fastening location on the wall through the holes. Drill holes in marked locations. Insert ANCHOR (L) completely into each drilled hole. Insert SCREWS (K) through the round holes on cabinet into anchors. Fasten the screws tightly with a Phillips screwdriver.

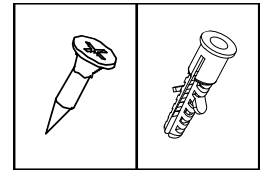

K (2)

L (2)

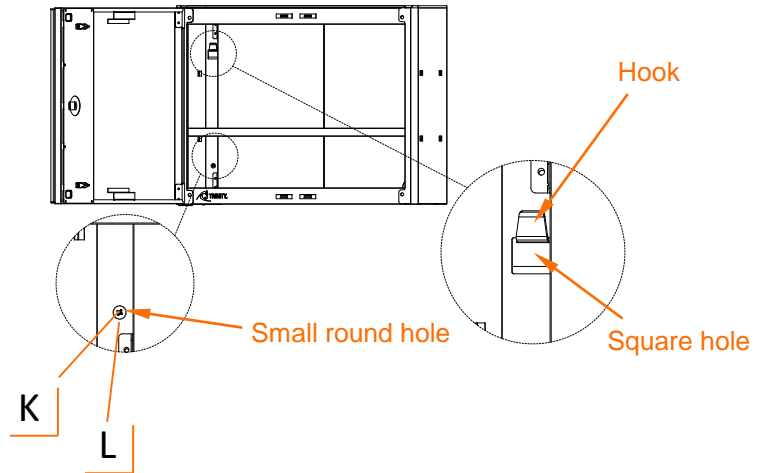

STEP 8

Attach SHELF SUPPORT (H) by hooking it over the position tab at your desired height. Make sure all four SHELF SUPPORTS (H) are at the same level.

Tilt SHELF (H) diagonally to move it inside the cabinet. Place SHELF (E) on top of all four SHELF SUPPORTS (H).

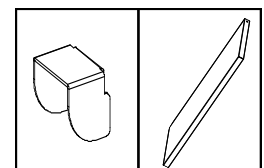

H (4)

E (1)

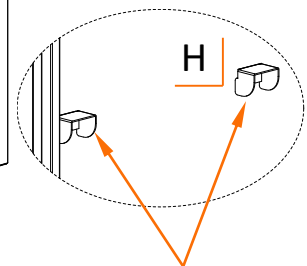
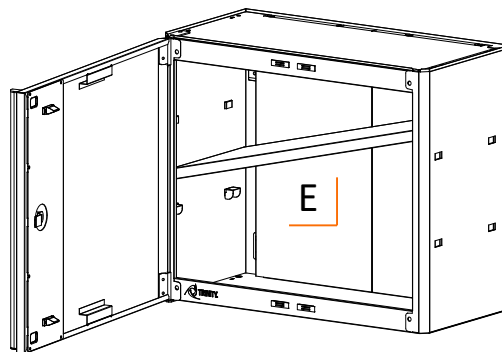

Shelf supports hooked on position tabs

USAGE INSTRUCTIONS

SHELF ADJUSTMENT

Ensure all products have been removed from the shelf.

To adjust the shelf, take the shelf out of the cabinet and re-attach the shelf supports to the position tabs at your desired height.

Tilt the shelf diagonally to move it inside the cabinet. Place the shelf on top of all four shelf supports.

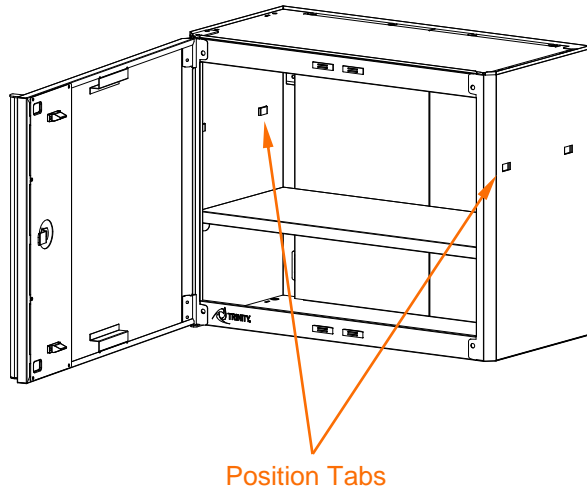

LOCK AND UNLOCK

Insert the key into the lock on the right door. Turn it clockwise 90 degree to lock the door. Turn it counter-clockwise 90 degree to unlock the door.

Before locking the unit, make sure the doors are fully closed.

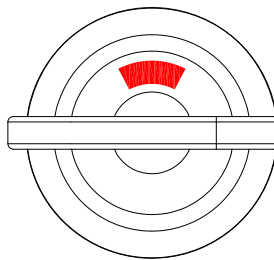

Red indicates locked

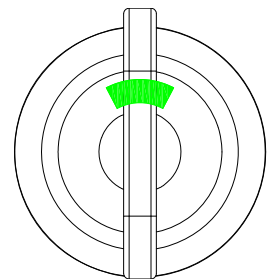

Green indicates unlocked

SERVICE PARTS LIST – TLSPBK-0604

TRINITY Customer Service provides the following replacement parts:

Part Number	Description	Part Number	Description
1) PBK-16-004-2411	Top Panel	9) PBK-08-008-2319	Door
2) PBK-18-018-2412	Cabinet Body	10) AMA-05-019-1850	Door Handle
3) XBK-02-001-0003	Magnetic Catcher	11) PBK-09-012-0001	Door Hinge-G
4) PBK-03-052-2410	Shelf	12) XBK-01-004-0612	Black Screw
5) XSV-02-017-0001	Shelf Support	13) PBK-19-005-2402	Wall Bracket
6) PBK-16-003-2411	Bottom Panel	14) ZSV-01-003-0530	Mounting Screw
7) XBK-10-001-0XXX	Key	15) XWH-01-032-0630	Anchor
8) PBK-09-011-0001	Door Hinge-F		

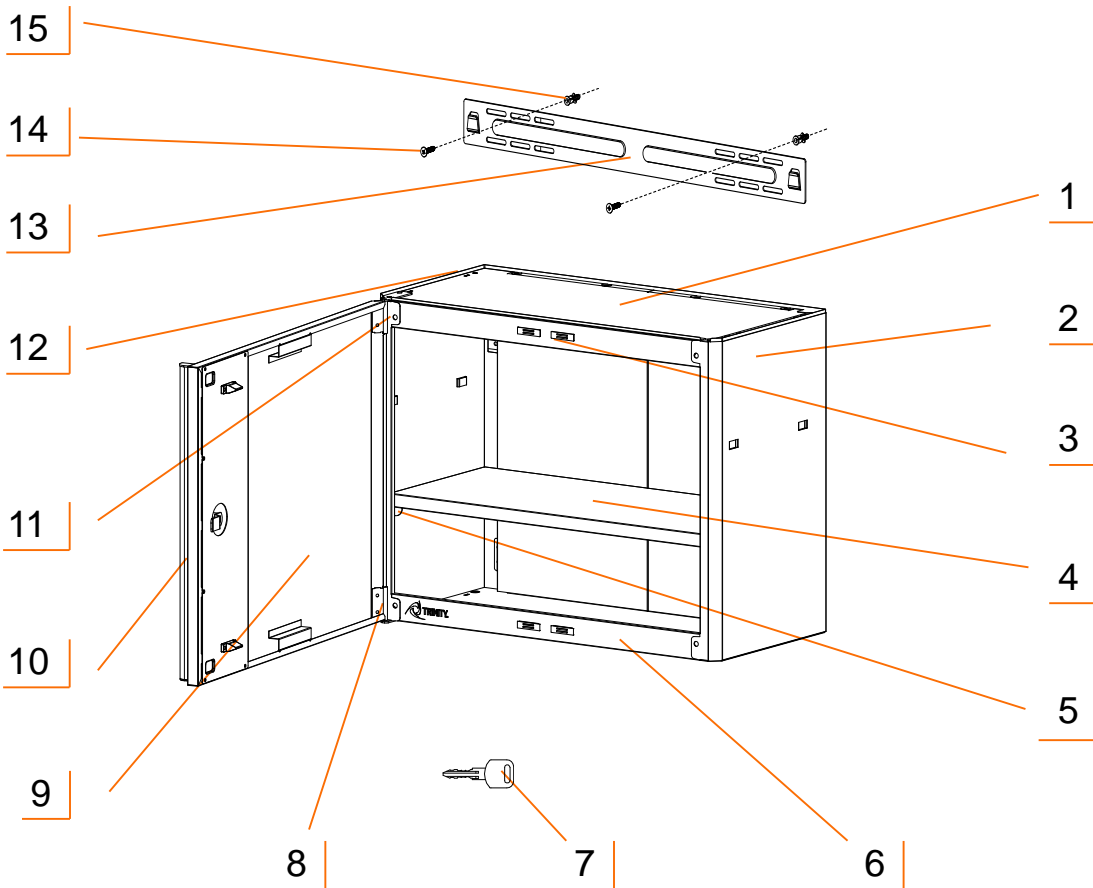

WARNINGS

1. **Read and understand all instructions.** Failure to follow all instructions may result in injury and/or damage.
2. **The warnings, cautions, and instructions discussed in this manual cannot cover all possible conditions or situations that may occur.** The user must always be aware of their environment and ensure that they use the product in a safe and responsible manner.
3. **Do NOT modify the product in any way.** Unauthorized modification may impair the function and/or safety of the product, and may affect the life of the product.
4. **Check for damaged parts.** Before using this product, carefully check that all parts are in good condition, and that the product will operate properly and perform its intended function. Check for damaged parts and any other conditions that may affect the operation of this product. Replace damaged or worn parts, and never use this product with a damaged part.
5. **Do NOT overload the product.**

Weight capacity of Shelf (evenly distributed)	50 lb
Total weight capacity of Cabinet (evenly distributed)	100 lb

CARE AND MAINTENANCE

- Avoid harsh, abrasive cleaners, and other corrosive chemicals.
- Do not use scouring pad for cleaning.
- This item is not certified for outdoor use.

PRODUCT REGISTRATION

Thank you for purchasing a TRINITY 24" Garage Wall Cabinet. In order to register your product and receive streamlined customer service, please fill out the following Product Registration Form and (1) fax the form to 310.347.4134 (2) complete the Product Registration Form online at www.trinityii.com or (3) scan and email the form to customerservice@trinityii.com. Include a copy of your original receipt with your submission.

First Name: _____ Last Name: _____

Address: _____

City: _____ State: _____ Zip Code: _____

Email Address: _____ Phone: _____

Product Model #: TLSPBK-0604 Purchase Date: ____ / ____ / ____

Location of Purchase: _____

Please rate the importance of each feature (1=least important; 10=most important)

Quality ____ Price ____ Size/Capacity ____ Appearance ____ Other ____

How did you hear about our product?

- Magazine Ad Catalog Salesperson Word of Mouth
 Internet Store Display Other

Marital Status: Single Married

Household Income: Below \$50,000 \$50,000-\$150,000 \$150,000+

Education: High School College Graduate School

Primary Residence: Own Rent

Comments/Suggestions:



1 YEAR LIMITED WARRANTY

TRINITY 24" Garage Wall Cabinet Model # TLSPBK-0604

Trinity International Industries ("TRINITY") warrants to the original consumer purchaser ("Purchaser") of the TRINITY 24" Garage Wall Cabinet ("Product") that each Product shall be free from defects in workmanship and materials for a period of 1 year from the date of original purchase. TRINITY's obligation under this warranty shall be limited to repair or replacement of, or adequate compensation for the Product which shall not be greater than the amount of the purchase price of the Product, at the option of TRINITY, during the warranty period. All replaced parts and Products become the property of TRINITY and must be returned to TRINITY.

This warranty excludes normal wear and tear of the Product and its parts or components, and damage arising from any of the following: negligent use or misuse of the Product, use contrary to this User's Manual, or alteration by any one other than TRINITY. The warranty period of 1 year shall not be extended or renewed by the repair or replacement of, or compensation for, the Product. Any warranty implied by applicable law is limited in duration to one year from the date of purchase and is subject to the same conditions and limitations as is provided for our express warranty.

Except as set forth herein, and to the extent of applicable there are no warranties on this Product either express or implied, and TRINITY disclaims all warranties including, but not limited to, any implied warranties of merchantability, infringement or fitness for a particular purpose. No warranty or guarantee given by any person, firm, or corporation with respect to this product shall be binding on TRINITY.

If your Product is defective or otherwise requires service or parts, please call TRINITY Customer Service toll-free at (800) 985-5506, between 8:00 a.m. and 5:00 p.m., PST. Please tell us which model you purchased, the date of the purchase, and the problem with your Product. A copy of your original purchase receipt must accompany your service request.

LIMITATION OF REMEDIES AND LIABILITY

TRINITY (and its employees, officers, members, managers, affiliates or assigns) shall not be liable for any incidental, consequential, special, indirect, remote, special or punitive damages for breach of any warranty, express or implied, including, but not limited to, lost profits, lost savings, loss of anticipated benefits and attorneys' fees, which arise out of the purchase, use or inability to use the Product, whether arising out of contract, negligence, strict tort, product liability, or any other legal theory on which a claim is based. As noted above, to the extent damages are allowed by our express warranty or by applicable law, those damages may not exceed the purchase price paid for the Product. Without limiting the foregoing Purchaser assumes all risk and liability for loss, damage or injury to Purchaser and Purchaser's property and to others and their property arising out of the use, misuse, or inability to use this Product. This limited warranty shall not extend to anyone other than the original purchaser of this product, is nontransferable and states your exclusive remedy.

Some states do not allow the exclusion or limitation of incidental, consequential, special, or punitive damages, so the above limitation or exclusion may not apply to you. The above warranty gives you specific legal rights, and you may have other rights which vary from state to state.

CONTACT US

**QUESTIONS? NEED PARTS?
WE ARE HERE TO HELP!**

Please feel free to contact us. There are no questions too small, or any problems too big. We're committed to providing our customers with the highest level of service.

TRINITY Customer Service

TEL: 800.985.5506

FAX: 310.347.4134

EMAIL: customerservice@trinityii.com

**Monday through Friday
5:00 AM – 5:00 PM (PT)**

www.trinityii.com



OWNER'S MANUAL

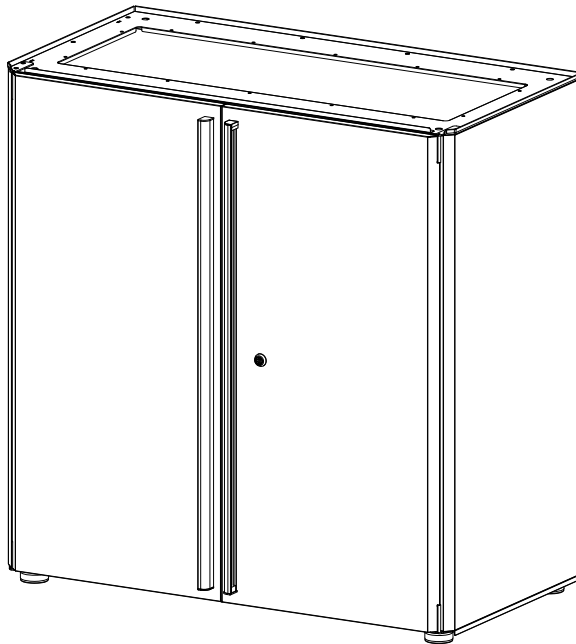

**TRINITY 36" Garage Modular Cabinet
Model # TLSPBK-0605**

PARTS LIST

Your TRINITY 36" Garage Modular Cabinet should include the following parts. Please inspect box contents to ensure you have received all components.

If you are missing any parts, need assistance with assembly or have questions, please contact TRINITY Customer Service: 800.985.5506 or customerservice@trinityii.com. Parts can also be requested online at www.trinityii.com (Help & More, Contact Us).

You will need a Phillips screwdriver for assembly which is not provided.

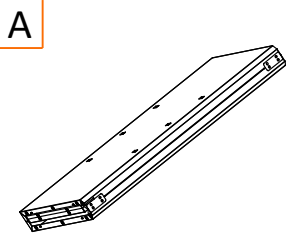

A
CABINET BODY (1)

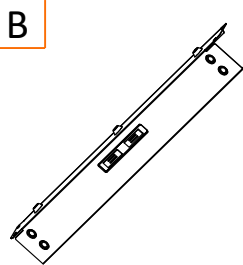

B
TOP PANEL (1)

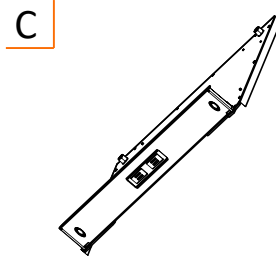

C
BOTTOM PANEL (1)

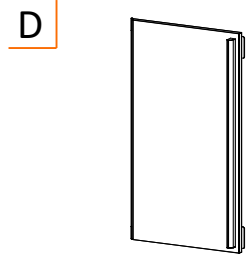

D
LEFT DOOR (1)

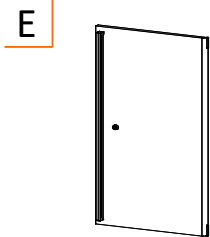

E
RIGHT DOOR (1)

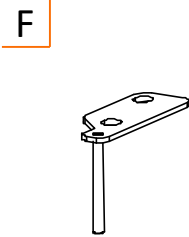

F
LEFT DOOR HINGE (1)

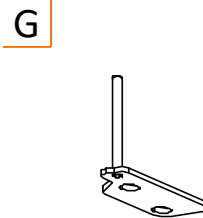

G
RIGHT DOOR HINGE (1)

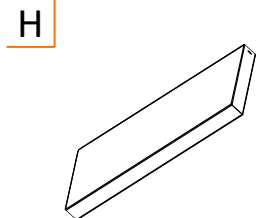

H
SHELF (1)

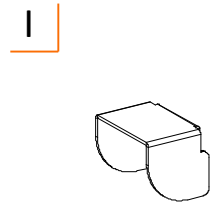

I
SHELF SUPPORT (4)

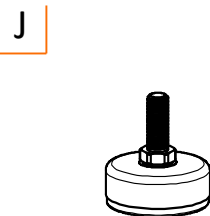

J
FEET LEVELER (4)

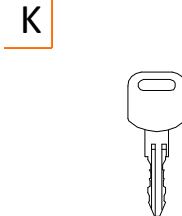

K
KEY (2)

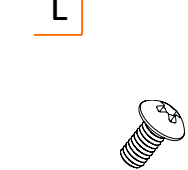

L
BLACK SCREW
(32) + (2) extra



M
MOUNTING SCREW (4)



N
ANCHOR (4)



O
CONNECTING SCREW (4)

ASSEMBLY INSTRUCTIONS

STEP 1

Unfold CABINET BODY (A).

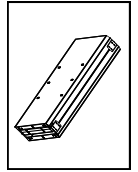

A (1)

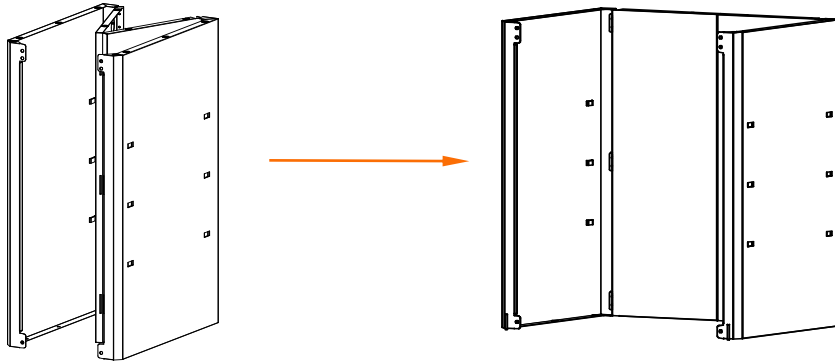

STEP 2

Two people are recommended for ease of assembly. Stand the unfolded CABINET BODY (A) upside down on the floor.

Note: There is a 40mm diameter hole on the back panel of the CABINET BODY (A). When the CABINET BODY (A) is upside down, this hole should be in the upper left corner of the back panel.

Turn BOTTOM PANEL (C) upside down. Tilt the front diagonally downward. First, insert the lip into the inner side of the tab of CABINET BODY (A) at the right side, then insert into the left side.

Follow the order indicated, insert (12) BLACK SCREWS (L) through holes on BOTTOM PANEL (C) and tighten fully with a Phillips screwdriver. Insert (4) BLACK SCREWS (L) through the tabs on the front of CABINET BODY (A) and tighten fully to BOTTOM PANEL (C).

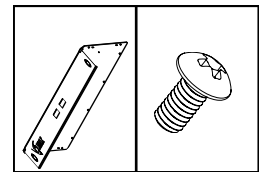

C (1)

L (16)

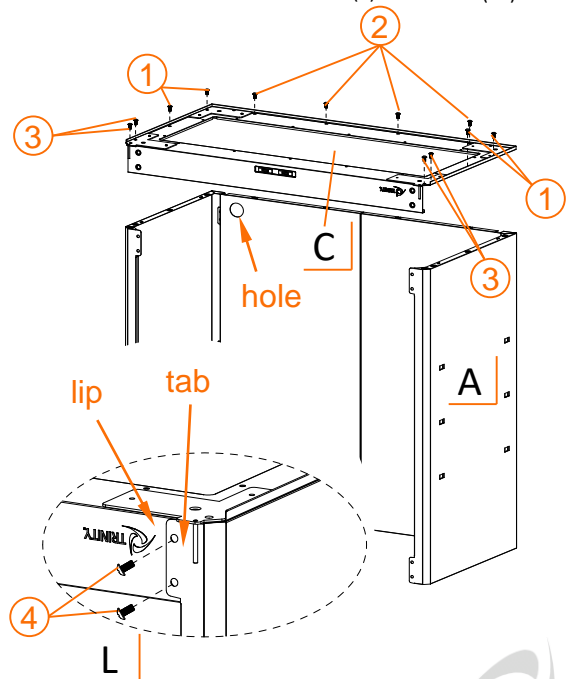

ASSEMBLY INSTRUCTIONS

STEP 3

Screw FEET LEVELERS (J) into each pre-installed nut in four corners of the BOTTOM PANEL (C).

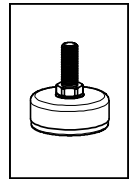
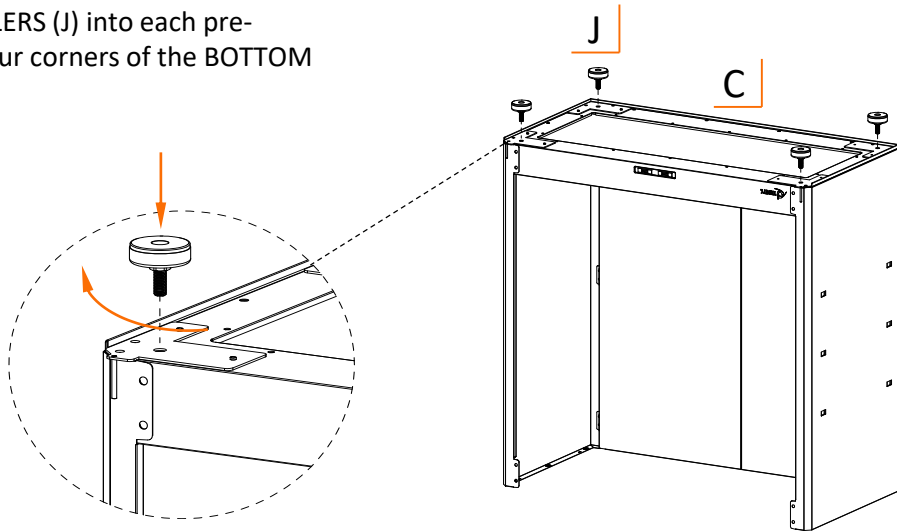

J (4)

STEP 4

Stand the unit right side up.

Tilt front of TOP PANEL (B) diagonally downward. First, insert the lip into the inner side of the tab of CABINET BODY (A) at the right side, then insert into the left side.

Follow the order indicated, insert (8) BLACK SCREWS (L) through holes on TOP PANEL (B) and tighten fully with a Phillips screwdriver. Insert (4) BLACK SCREWS (L) through the tabs on the front of CABINET BODY (A) and tighten fully to TOP PANEL (B).

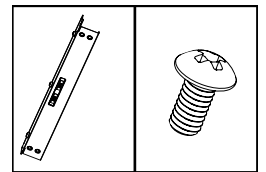

B (1)

L (12)

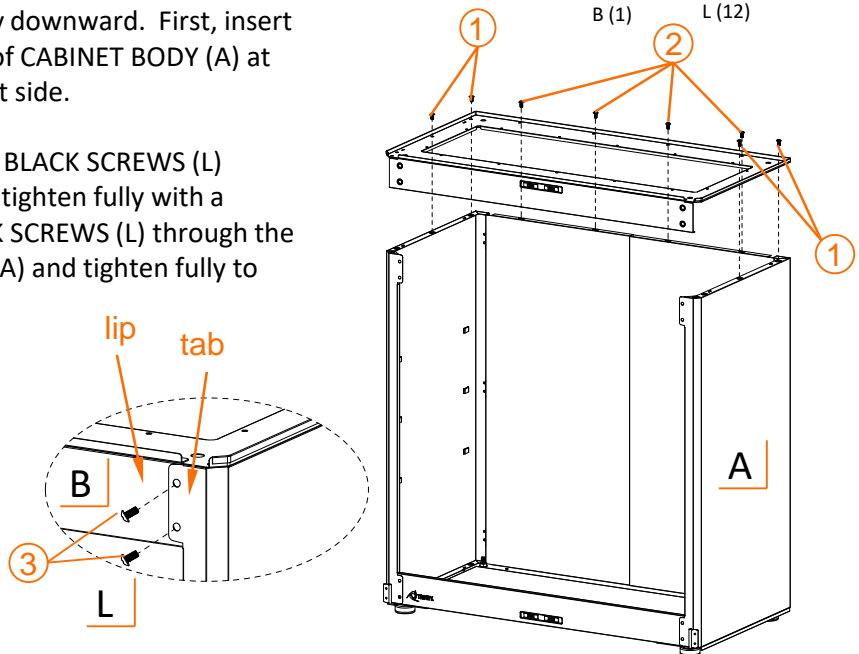

ASSEMBLY INSTRUCTIONS

STEP 5

Note: RIGHT DOOR (E) has a lock on it.

Attach LEFT DOOR (D) to the cabinet by sliding the LEFT DOOR (D) onto the pivot of door hinge which is welded to the BOTTOM PANEL (C)

Position LEFT DOOR HINGE (F) at the left front corner of TOP PANEL (B). Make sure to insert the pivot of DOOR HINGE (F) fully into the cylinder on the LEFT DOOR (D). Align holes on DOOR HINGE (F) to pre-installed nuts on TOP PANEL (B). Insert BLACK SCREWS (L) through these holes. Tighten fully with a Phillips screwdriver.

Repeat for RIGHT DOOR (E).

Adjust FEET LEVELER (J) as needed to ensure your cabinet is level and stable.

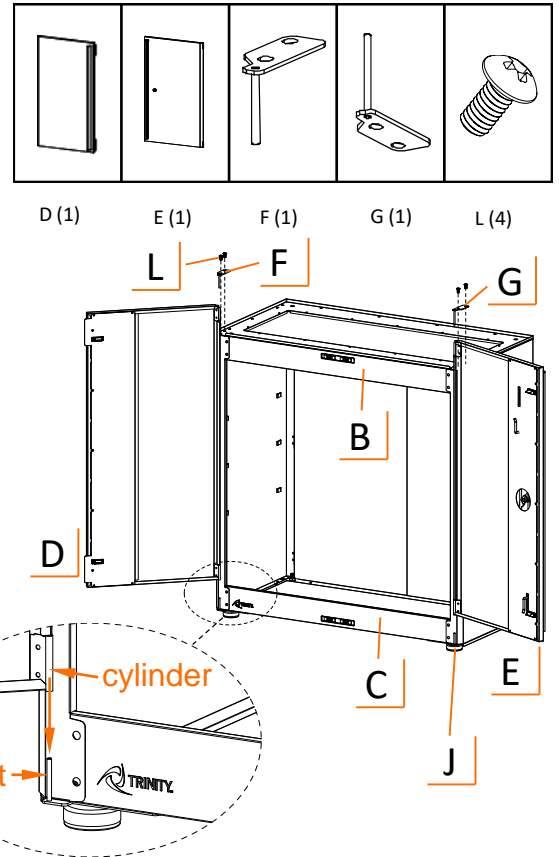

STEP 6

Attach SHELF SUPPORT (I) by hooking it over the position tab at the desired height. Make sure all four SHELF SUPPORTS (I) are at the same level.

Tilt SHELF (H) diagonally to move it inside the cabinet. Place SHELF (H) on top of all four SHELF SUPPORTS (I).

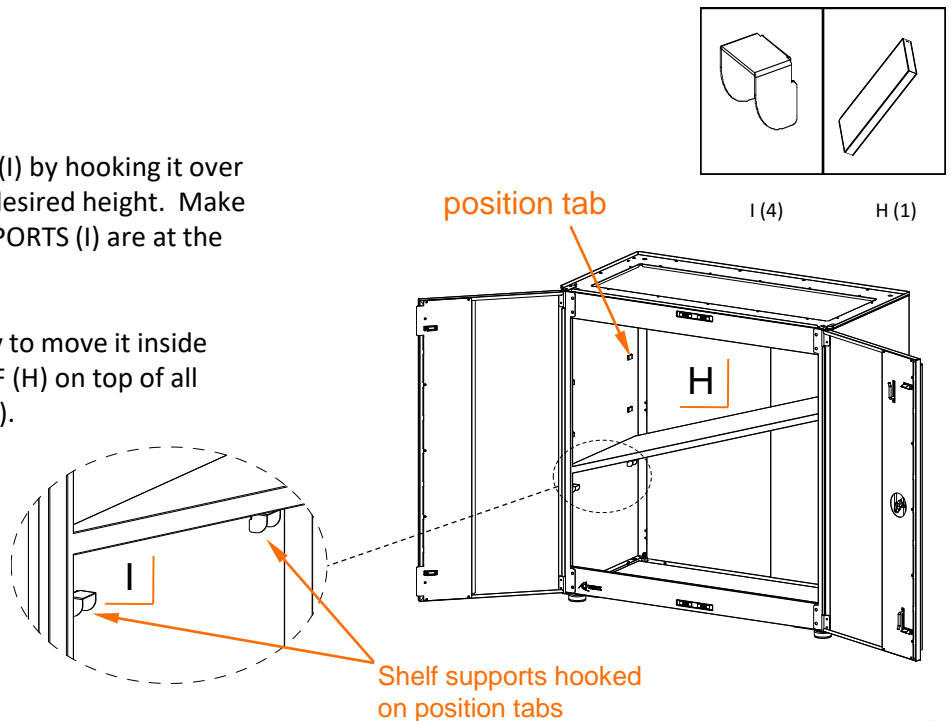

USAGE INSTRUCTIONS

SHELF ADJUSTMENT

Ensure all products have been removed from the shelf.

To adjust the shelf height position, take the shelf out of the cabinet, re-attach the shelf supports to the position tabs at your desired height.

Tilt the shelf diagonally to move it inside the cabinet. Place the shelf on top of all four shelf supports.

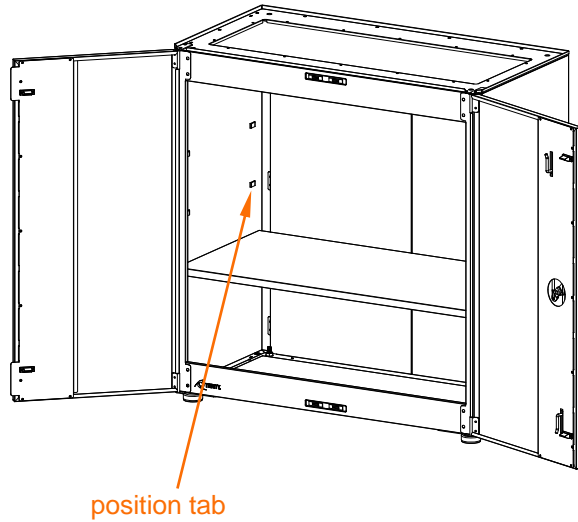

LOCK AND UNLOCK

Insert the key into the lock on the right door. Turn it clockwise 90 degree to lock the door. Turn it counter-clockwise 90 degree to unlock the door.

Before locking the unit, make sure the doors are fully closed.

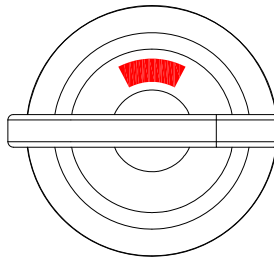

Red indicates locked

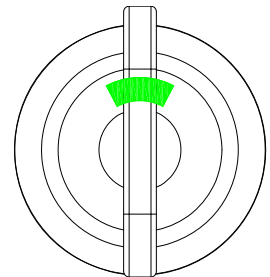

Green indicates unlocked

USAGE INSTRUCTIONS

STACKING CABINETS

You can make a taller cabinet by stacking two cabinets of the same model.

To store long/tall items, the pre-assembled top center and bottom center panels can be removed. Unscrew the center panel from the top of the first assembled cabinet.

Lay the second assembled cabinet carefully on its backside. Two people are needed. **DO NOT** attempt this alone. Unscrew the center panel and feet levelers from the bottom.

Carefully set the cabinet upright. Position the second cabinet on top of the first cabinet. Align the bottom panel of top cabinet to the top panel of bottom cabinet. Make sure the bottom frame of top cabinet sits inside the top frame of bottom cabinet. Screw **CONNECTING BOLTS (O)** through the holes in four corners of the top panel of bottom cabinet into the pre-installed nuts in four corners of bottom panel of top cabinet.

Move the stacked cabinet carefully against wall. There are four small holes on back side of the cabinet to be used for securing the cabinets to the wall.

If needed, use a pencil to mark off the fastening location on the wall through these holes. Drill holes in marked locations. Insert a **ANCHOR (N)** completely into each drilled hole.

Fasten **MOUNTING SCREWS (M)** through the holes on cabinet onto the wall or anchors tightly by a screwdriver.

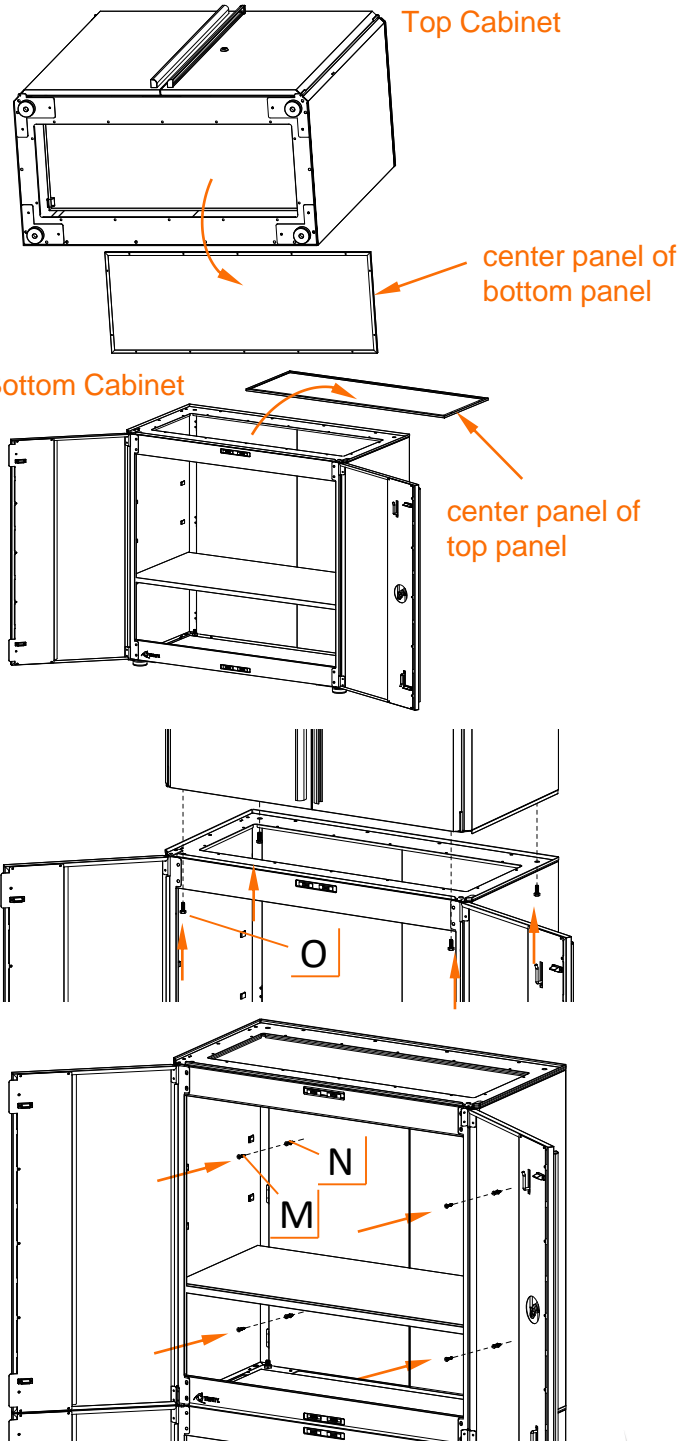

SERVICE PARTS LIST – TLSPBK-0605

TRINITY Customer Service provides the following replacement parts:

Part Number	Description	Part Number	Description
1) PBK-16-004-3618	Top Panel	9) XWH-98-001-4264	Feet Leveler
2) PBK-18-018-3618	Cabinet Body	10) PBK-08-007-1736	Left Door
3) PBK-09-011-0001	Right Door Hinge	11) AMA-05-019-3400	Door Handle
4) PBK-08-006-1736	Right Door	12) XBK-02-001-0003	Magnetic Catch
5) PBK-03-052-3617	Shelf	13) PBK-09-012-0001	Left Door Hinge
6) XSV-02-017-0001	Shelf Support	14) XBK-01-004-0612	Black Screw
7) PBK-16-003-3618	Bottom Panel	15) ZSV-01-035-0925	Connecting Bolt
8) XBK-10-001-0XXX	Key		

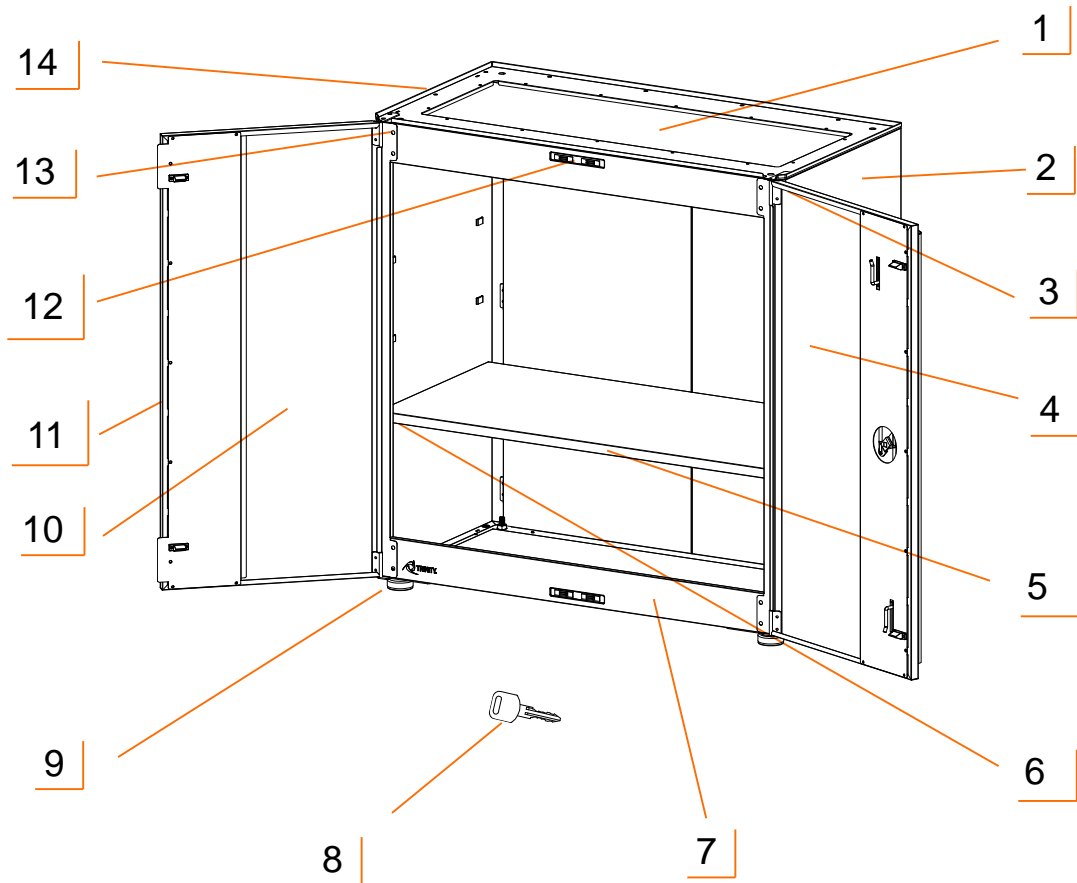

WARNINGS

1. **Read and understand all instructions.** Failure to follow all instructions may result in injury and/or damage.
2. **The warnings, cautions, and instructions discussed in this manual cannot cover all possible conditions or situations that may occur.** The user must always be aware of their environment and ensure that they use the product in a safe and responsible manner.
3. **Do NOT modify the product in any way.** Unauthorized modification may impair the function and/or safety of the product, and may affect the life of the product.
4. **Check for damaged parts.** Before using this product, carefully check that all parts are in good condition, and that the product will operate properly and perform its intended function. Check for damaged parts and any other conditions that may affect the operation of this product. Replace damaged or worn parts, and never use this product with a damaged part.
5. **Do NOT overload the product.**

Weight capacity of Shelf (evenly distributed)	100 lb
Total weight capacity of Cabinet (evenly distributed)	300 lb

6. **Do NOT stack more than two cabinets together.**

CARE AND MAINTENANCE

- Avoid harsh, abrasive cleaners, and other corrosive chemicals.
- Do not use scouring pad for cleaning.
- This item is not certified for outdoor use.

PRODUCT REGISTRATION

Thank you for purchasing a TRINITY 36" Garage Modular Cabinet. In order to register your product and receive streamlined customer service, please fill out the following Product Registration Form and (1) fax the form to 310.347.4134 (2) complete the Product Registration Form online at www.trinityii.com or (3) scan and email the form to customerservice@trinityii.com. Include a copy of your original receipt with your submission.

First Name: _____ Last Name: _____

Address: _____

City: _____ State: _____ Zip Code: _____

Email Address: _____ Phone: _____

Product Model #: TLSPBK-0605 Purchase Date: ____ / ____ / ____

Location of Purchase: _____

Please rate the importance of each feature (1=least important; 10=most important)

Quality ____ Price ____ Size/Capacity ____ Appearance ____ Other ____

How did you hear about our product?

- Magazine Ad Catalog Salesperson Word of Mouth
 Internet Store Display Other

Marital Status: Single Married

Household Income: Below \$50,000 \$50,000-\$150,000 \$150,000+

Education: High School College Graduate School

Primary Residence: Own Rent

Comments/Suggestions:



1 YEAR LIMITED WARRANTY

TRINITY 36" Garage Modular Cabinet Model # TLSPBK-0605

Trinity International Industries ("Trinity") warrants to the original consumer purchaser ("Purchaser") of the TRINITY 36" Garage Modular Cabinet ("Product") that each Product shall be free from defects in workmanship and materials for a period of 1 year from the date of original purchase. Trinity's obligation under this warranty shall be limited to repair or replacement of, or adequate compensation for the Product which shall not be greater than the amount of the purchase price of the Product, at the option of Trinity, during the warranty period. All replaced parts and Products become the property of Trinity and must be returned to Trinity.

This warranty excludes normal wear and tear of the Product and its parts or components, and damage arising from any of the following: negligent use or misuse of the Product, use contrary to this User's Manual, or alteration by any one other than Trinity. The warranty period of 1 year shall not be extended or renewed by the repair or replacement of, or compensation for, the Product. Any warranty implied by applicable law is limited in duration to one year from the date of purchase and is subject to the same conditions and limitations as is provided for our express warranty.

Except as set forth herein, and to the extent of applicable there are no warranties on this Product either express or implied, and Trinity disclaims all warranties including, but not limited to, any implied warranties of merchantability, infringement or fitness for a particular purpose. No warranty or guarantee given by any person, firm, or corporation with respect to this product shall be binding on Trinity.

If your Product is defective or otherwise requires service or parts, please call TRINITY Customer Service toll-free at (800) 985-5506, between 8:00 a.m. and 5:00 p.m., PST. Please tell us which model you purchased, the date of the purchase, and the problem with your Product. A copy of your original purchase receipt must accompany your service request.

LIMITATION OF REMEDIES AND LIABILITY

Trinity (and its employees, officers, members, managers, affiliates and assigns) shall not be liable for any incidental, consequential, special, indirect, remote, special or punitive damages for breach of any warranty, express or implied, including, but not limited to, lost profits, lost savings, loss of anticipated benefits and attorneys' fees, which arise out of the purchase, use or inability to use the Product, whether arising out of contract, negligence, strict tort, product liability, or any other legal theory on which a claim is based. As noted above, to the extent damages are allowed by our express warranty or by applicable law, those damages may not exceed the purchase price paid for the Product. Without limiting the foregoing Purchaser assumes all risk and liability for loss, damage or injury to Purchaser and Purchaser's property and to others and their property arising out of the use, misuse, or inability to use this Product. This limited warranty shall not extend to anyone other than the original purchaser of this product, is nontransferable and states your exclusive remedy.

Some states do not allow the exclusion or limitation of incidental, consequential, special, or punitive damages, so the above limitation or exclusion may not apply to you. The above warranty gives you specific legal rights, and you may have other rights which vary from state to state.

CONTACT US

**QUESTIONS? NEED PARTS?
WE ARE HERE TO HELP!**

Please feel free to contact us. There are no questions too small, or any problems too big. We're committed to providing our customers with the highest level of service.

TRINITY Customer Service

TEL: 800.985.5506

FAX: 310.347.4134

EMAIL: customerservice@trinityii.com

**Monday through Friday
5:00 AM – 5:00 PM (PST)**

www.trinityii.com