



OWNER'S MANUAL
**56" X 24" HUTCH
AND TOOL CABINET**

M562411TC-H

www.montezumastorage.com

LIFE ORGANIZED

Montezuma is committed to helping you succeed in both your work and personal life by being organized, prepared and equipped with the right tools, gear and home supplies at your finger tips.

We are here to ensure that your life is organized.

Thank you for your purchase of this Montezuma Hutch and Cabinet.

ATTENTION

TO REDUCE THE RISK OF INJURY, THE USER MUST READ AND UNDERSTAND THIS INSTRUCTION MANUAL BEFORE USING THIS PRODUCT FOR THE FIRST TIME. SAVE THESE INSTRUCTIONS FOR FUTURE REFERENCE.

Fill in the following information and retain this owner's manual for future reference:

MODEL(S):

DATE OF PURCHASE:

PLACE OF PURCHASE:

RECEIPT NO:

SPECIFICATIONS

MAXIMUM PRODUCT WEIGHT (INCLUDING CONTENTS): 2,100 lb (952 kg)

MAXIMUM SHELF WEIGHT CAPACITY (HUTCH): 100 lb (45 kg)

MAXIMUM DRAWER WEIGHT (CABINET): 150 lb (68 kg)

POWER STRIP

MODEL: LTS-04C/CH-04F

SURGE PROTECTIVE DEVICES

RATING: 120 V AC 15 A 60 Hz 1875 W

USB: TOTAL 2.1 A – Check your device for compatibility

USB O/P: IT EQUIPMENT ONLY

VPR: 500-1000 V (L-N) TYPE 3 SPD

CONFORMS TO UL STD. NO 1363 AND ANSI/UL STD. NO. 1449

CERTIFIED TO CSA STD. C22.2 NO. 308&8

56" x 24" HUTCH AND TOOL CABINET

M562411TC-H

OVERALL DIMENSIONS:

56" W x 24-5/8" D x 66-1/8" H
(142.2 cm W x 62.5 cm D x 168 cm H)
NET WEIGHT: 489 lb (222 kg)

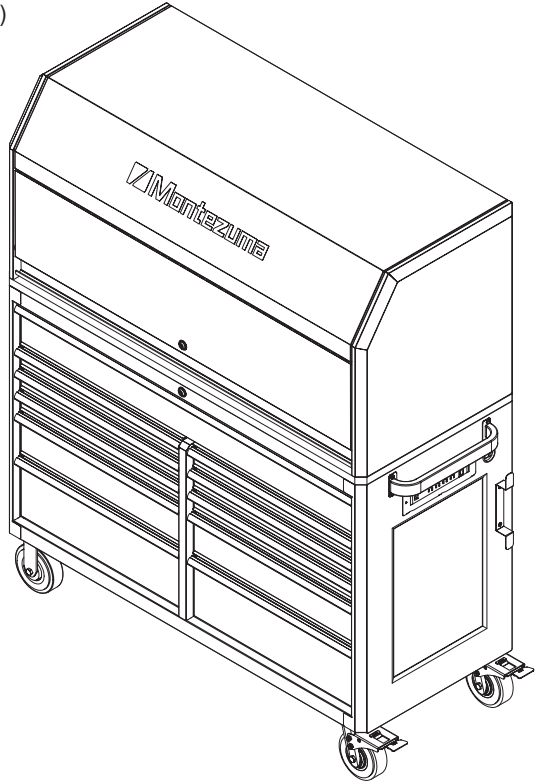

HUTCH DIMENSIONS:

56" W x 24-5/8" D x 25" H
(142.2 cm W x 62.5 cm D x 63.5 cm H)

CABINET DIMENSIONS:

56" W x 24-5/8" D x 41-1/8" H
(142.2 cm W x 62.5 cm D x 104.5 cm H)

INSIDE DRAWER DIMENSIONS:

REF	DIMENSIONS	QTY
A	51-7/8" W x 21-1/8" D x 5-1/8" H (131.7 cm W x 53.8 cm D x 12.9 cm H)	1
B	24-3/4" W x 21-1/8" D x 2-3/8" H (62.9 cm W x 53.8 cm D x 5.9 cm H)	6
C	24-3/4" W x 21-1/8" D x 5-1/4" H (62.9 cm W x 53.8 cm D x 13.4 cm H)	2
D	24-3/4" W x 21-1/8" D x 8-1/4" H (62.9 cm W x 53.8 cm D x 20.9 cm H)	2

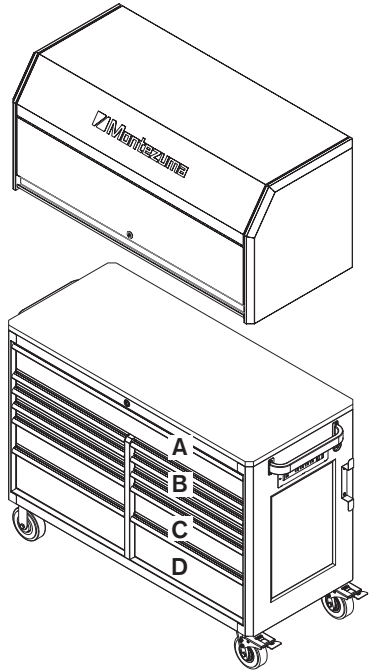

* Dimensions do not include side handles.

HUTCH PARTS LIST

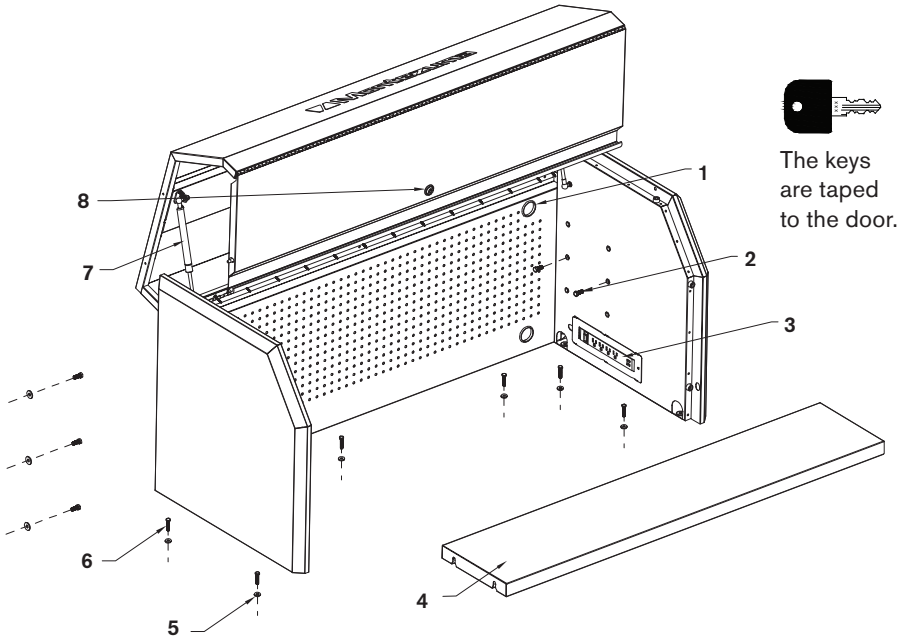

REF	DESCRIPTION	PART NUMBER	QTY
1	Grommet	314027	4
2	M8 x 20 Hex Bolt	321024	16
3	Power Strip	333059	1
4	Shelf	242035	1
5	Washer	324002	16
6	M8 x 40 Hex Bolt	321048	6
7	Gas Strut	303218	2
8	Lock and Key (1201-1204)	304166	2

To order replacement parts, email service@montezumastorage.com or call 1-800-459-4409 (Monday–Friday, 8:00 am–4:30 pm, CST). Have the part number and quantity ready. Replacement keys may be ordered using the code that appears on the face of the lock. Not all parts are covered under warranty. Those parts not covered can be purchased.

4

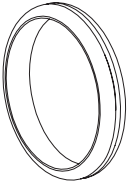

Grommet

For cord access

16

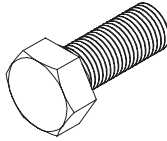

M8 x 20 Hex Bolt

6 for attaching side panels

4 for supporting adjustable shelf

6 for connecting hutch to cabinet without worktop (optional)

1

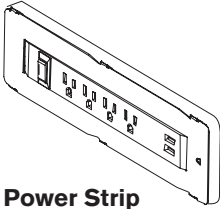

Power Strip

For power management

1

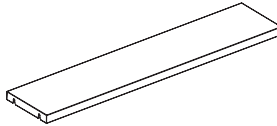

Shelf

For placing at desired height

16

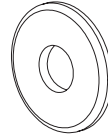

Washer

For use with M8 x 20 Hex Bolt

6

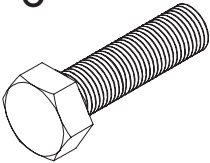

M8 x 40 Hex Bolt

For connecting the hutch and cabinet together

2

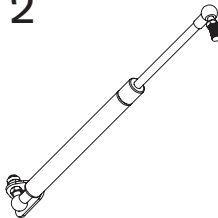

Gas Strut

For lifting the hutch lid

2

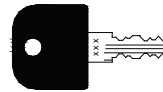

Lock and Key

For securing your valuables

CABINET PARTS LIST

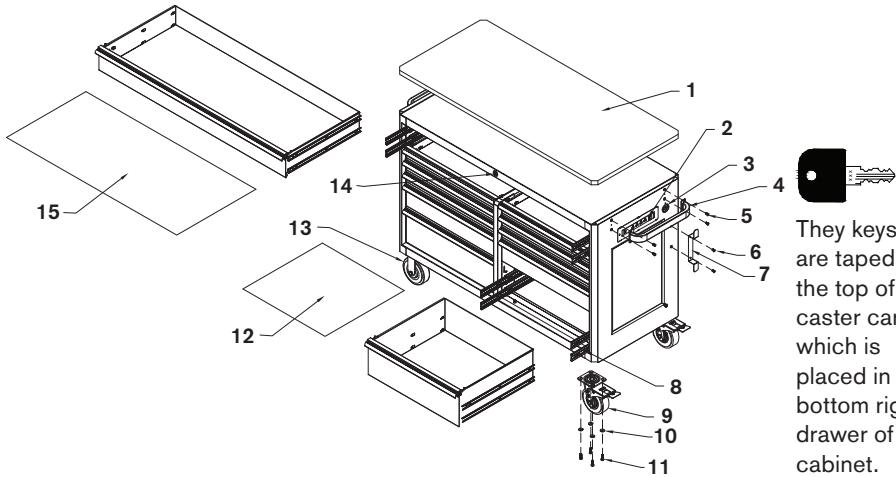

REF	DESCRIPTION	PART NUMBER	QTY
1	Work Top	572013	1
2	Power Strip	333059	1
3	Grommet	314027	1
4	Cabinet Handle	306142	2
5	M6 x 12 mm Hex Bolt	321051	8
6	M6 x 12 mm Phillips Head Bolt	320323	2
7	Cord Wrap	236870	1
8	Slide Set	300380-300381	14
9	Swivel Caster	302074	2
10	Washer	324002	16
11	M8 x 25 mm Hex Bolt	321047	16
12	Drawer Liner	551894	10
13	Rigid Caster	302003	2
14	Lock and Key (1201-1204)	304166	1
15	Drawer Liner	551895	1

To order replacement parts, email service@montezumastorage.com or call 1-800-459-4409 (Monday-Friday, 8:00 am-4:30 pm, CST). Have the part number and quantity ready. Replacement keys may be ordered using the code that appears on the face of the lock. Not all parts are covered under warranty. Those parts not covered can be purchased.

1

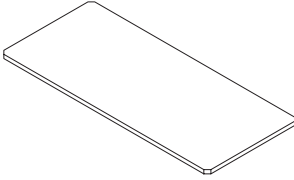

Work Top

For using as a work surface

1

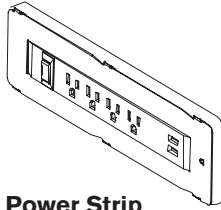

Power Strip

For power management

1

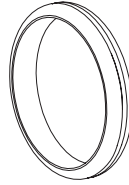

Grommet

For cord access

2

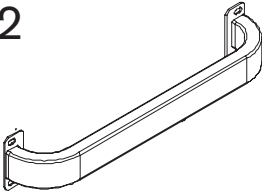

Cabinet Handle

For assisting in moving the cabinet

8

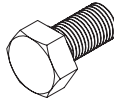

M6 x 12 mm Hex Bolt

For attaching the cabinet handles

2



M6 x 12 mm Phillips Head Bolt

For attaching the cord wrap

1



Cord Wrap

For holding the power cord

14

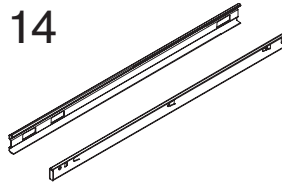

Slide Set

Pre-installed
For installing drawers

2

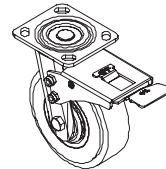

Swivel Caster

For supporting the cabinet

16

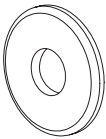

Washer

For use with M8 x 25 mm Hex Bolt

16

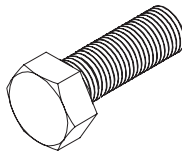

M8 x 25 mm Hex Bolt

For attaching casters

10

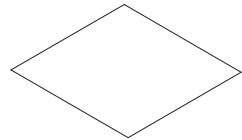

Drawer Liner

For protecting narrower drawers

2

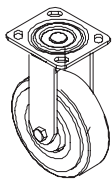

Rigid Caster

For supporting the cabinet

1



Lock and Key

For securing
your valuables

1

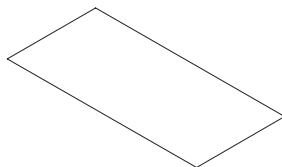

Drawer Liner

For protecting wide drawer

CABINET HANDLE INSTALLATION

NOTE: Assemble the handles first to make it easier to move the cabinet.

Position the handles over the holes in the cabinet and attach with the M6 x 12 mm hex bolts provided. Tighten securely using a 10 mm socket.

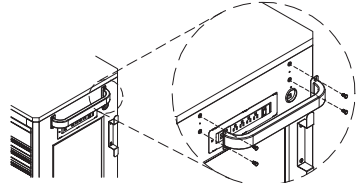

CASTER INSTALLATION

CAUTION: Two or more people are required to lay down or stand up the cabinet. Use the side handles for assistance. **DO NOT** stand in front of or behind the product during this process. Lock drawers before proceeding.

Carefully lay the cabinet on its back, with a soft mat underneath for protection.

Position the two swivel casters on the cabinet bottom, on either the left or right side. Insert four M8 x 25 mm hex bolts through washers, then through each caster and into the bottom of the cabinet. Tighten securely using a 14 mm socket.

Repeat for the two rigid casters on the other side of the cabinet.

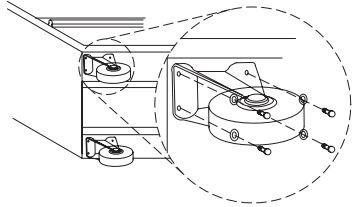

CABINET CORD WRAP INSTALLATION

Position the cord wrap over the holes in the cabinet. Attach with the M6 x 12 mm Phillips head bolts provided. Tighten securely.

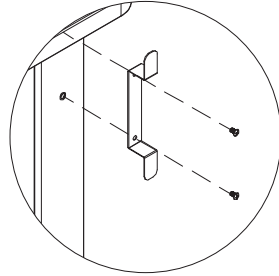

CABINET POWER STRIP INSTALLATION

Cut the black strip holding the cord, then pull the white strip to get the plug out of the cabinet and through the grommet. Tighten the grommet.

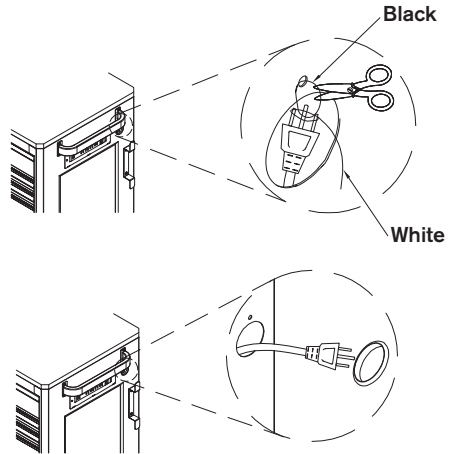

HUTCH ASSEMBLY

Unfold the hutch body as shown.

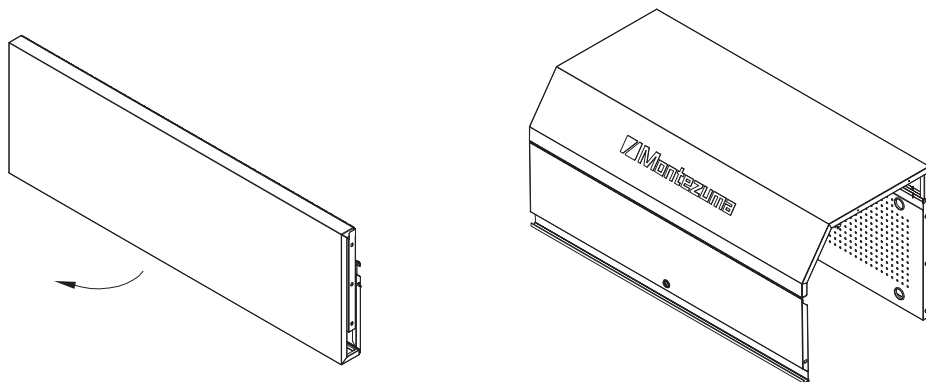

Attach the left and right side panels to the back of the hutch body using three M8 x 20 hex bolts and washers per panel.

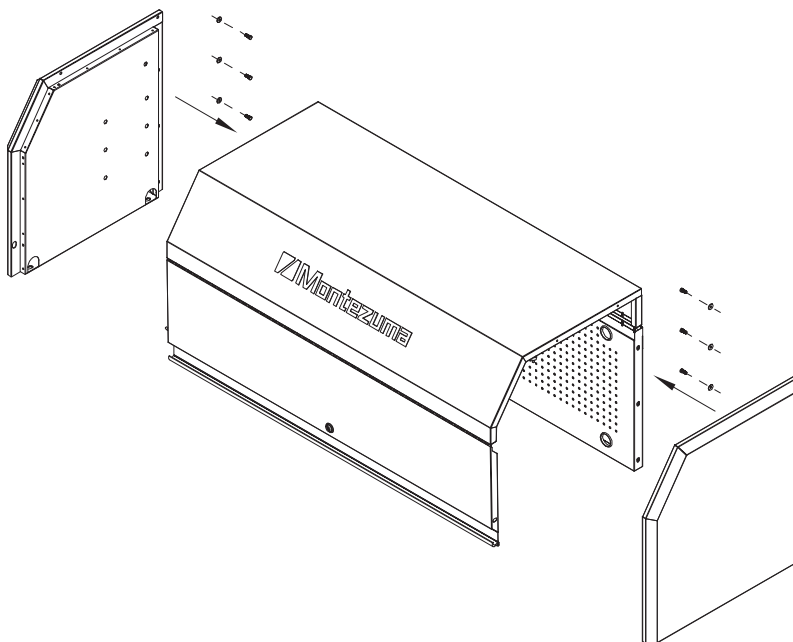

Open the hutch door and install the gas strut.

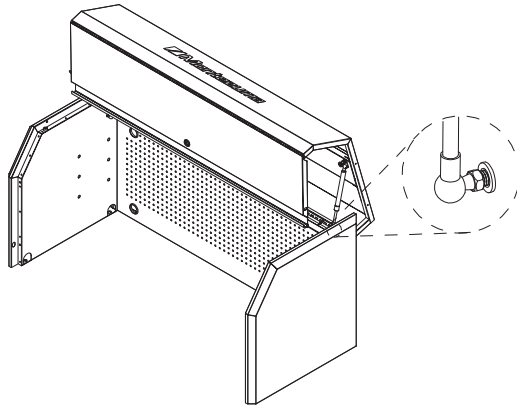

Proceed with connecting the hutch to the cabinet before installing the shelf in the hutch.

HUTCH-CABINET CONNECTION

WARNING: FOR YOUR SAFETY, MOUNT THE HUTCH TO THE CABINET USING ONLY THE HARDWARE PROVIDED.

CONNECTING THE HUTCH TO A CABINET WITH A WORKTOP

Put the hutch onto the worktop. Make sure that both the hutch and the worktop are flush with the front edge of the cabinet and that there are equal gaps on the sides.

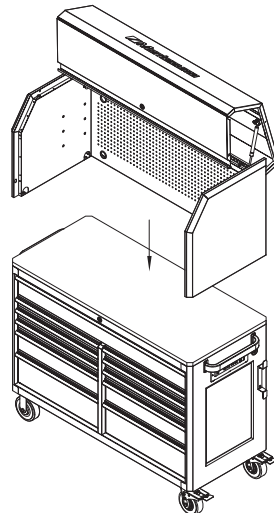

On the worktop, mark the locations of the six slotted holes in the hutch.

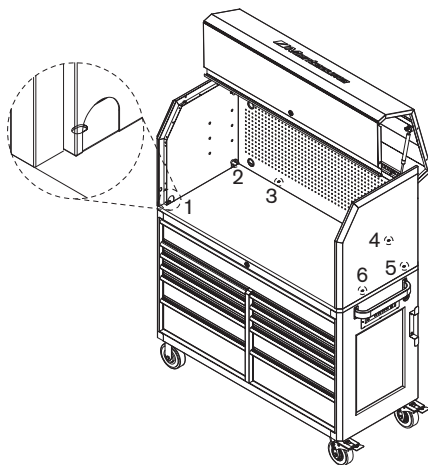

Take the hutch off the cabinet. Remove the worktop by first removing the drawers, then loosening the M6 x 12 Phillips head bolts.

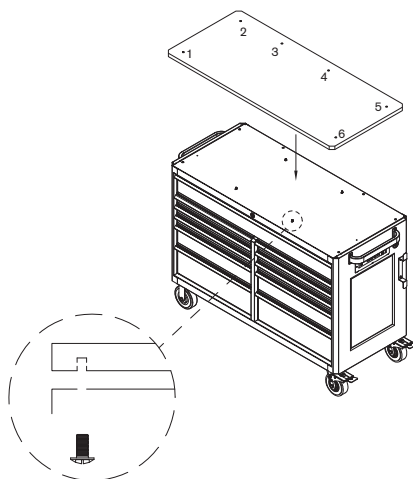

Place the worktop on the floor. Drill six 7/16" (1.1 cm) holes at the locations you marked.

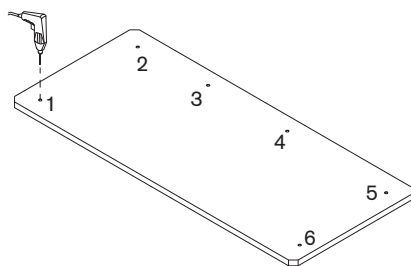

Place the worktop and hutch back onto the cabinet. Make sure that both the hutch and the worktop are flush with the front edge of the cabinet and that there are equal gaps on the sides.

Connect the hutch, worktop and cabinet together using six M8 x 40 hex bolts and washers. An open end wrench is recommended for tightening the hex bolts.

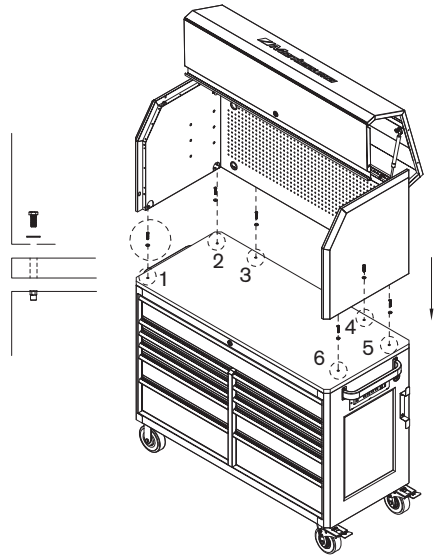

Install the shelf in the hutch using four M8 x 20 hex bolts and washers.

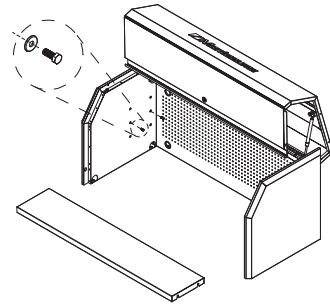

CONNECTING THE HUTCH TO A CABINET WITHOUT A WORKTOP

You may also install the hutch on the cabinet without a worktop.

Remove the worktop by first removing the drawers, then loosening the M6 x 12 Phillips head bolts.

Place the hutch directly on the cabinet and attach with six M8 x 20 hex bolts. An open end wrench is recommended for tightening the hex bolts.

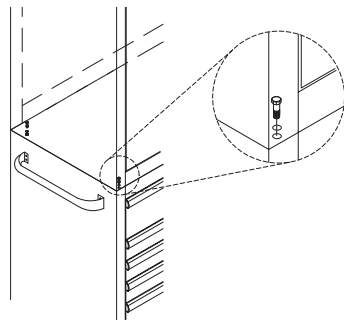

RAISE AND RELEASE DRAWER FRONTS

These units are equipped with raise and release drawer fronts. To open, lift up on the drawer front while pulling towards you. To close, shut the drawer firmly until the latch engages.

If the drawer does not stay closed, the hook may be bent, or it may be rubbing against the drawer slides. To fix this problem, lightly bend the hook until the drawer will engage in the slide.

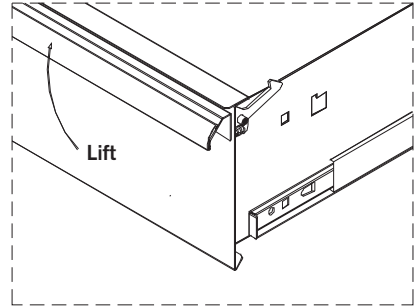

DRAWER REMOVAL

Pull the drawer out so that it's almost fully extended. Push up on the black release lever on one side, while pushing down on the black release lever on the other side. While holding the levers in these positions, pull the drawer outward until it is released from the drawer slide.

ONE SIDE – PUSH UP

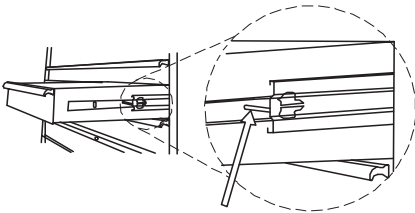

OTHER SIDE – PUSH DOWN

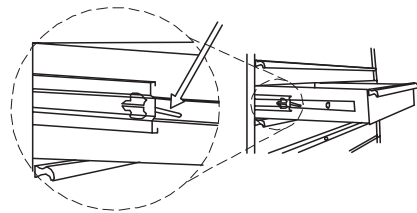

DRAWER REPLACEMENT

Extend the drawer slides from the unit. Insert the brackets on each side of the drawer into the slots in the slides, being careful that they are properly positioned. Once properly inserted, completely close the drawer to set the slides in position.

MAINTENANCE

Periodically clean the drawer fronts, trim, and other surfaces with mild detergent and water.

Lubricate the casters with high quality bearing grease (annually/yearly).

Lubricate the slides (twice a year) with a product like WD40 or other quality lubricant. This is especially important in low temperatures, which can cause the bearing to become stiff.

Grease and oil can be removed with most standard cleaning fluids. For safety, use a nonflammable cleaning fluid.

SAFETY

RISK OF ELECTRIC SHOCK. To reduce the risk of electric shock, use indoors in a dry location only. Do not plug the power strip into another power strip. Not for use for a permanent installation.

Changes or modifications to this unit not expressly approved by the party responsible for compliance could void the user's authority to operate the equipment.

Close the cover and lock the drawers before moving this product. The drawers could come open and make the product unstable and tip, which may cause personal injury or product damage.

Do not attempt to lift the unit by its side handles using chains, ropes or other lifting devices. The side handle could fail, which may cause personal injury or damage to the product.

DO NOT stand on this product or lean on the drawers or work surface.

WEAR SAFETY GLASSES when removing or repositioning the slides. The tool could slip, which may cause personal injury.

When moving this product, do not pull it. Push the product to prevent personal injury.

USE THE BRAKES when not moving this product. This will prevent the product from rolling, which may cause personal injury or product damage.

BE CAREFUL when opening more than one drawer. The product could become unstable and tip, which may cause personal injury or product damage.

DO NOT mount this product on a truck bed or any other moving object. This may cause personal injury or product damage, and will void the warranty.

Secure this product properly before moving it with a forklift.

DO NOT tow with power equipment. The product could tip, which may cause personal injury or product damage.

Keep the product on level surfaces. The product could become unstable and tip if stored or moved on an uneven surface, which may cause personal injury or product damage.



This product is warranted to be free from defects in materials and workmanship for a period of five (5) years from the date of original purchase.

If this product is defective, email service@montezumastorage.com or call 1-800-459-4409 (Monday–Friday, 8:00 am–4:30 pm, CST). If the product is defective, we will replace the defective part at no cost to you.

Please do not ship your product back to the store or to us unless we send you written instructions for return.

In the event it becomes necessary for your product to be returned, we will notify you how to proceed.

A copy of your original purchase receipt must accompany the returned product.



Manufactured by:

QUALITY CRAFT

Surrey, BC, Canada V3S 5N4

service@montezumastorage.com

1-800-459-4409

(Monday to Friday, 8:00 am–4:30 pm, CST)

Made in China