



LINII

## **ARRA<sup>2</sup> PRAM**

### Instruction Manual



Embracing Safety, Durability, Beauty & Healthy Lifestyle

## IMPORTANT!

- Read all instructions and warnings thoroughly before commencing assembly or use of your Arra pram and **keep these instructions for future reference.**
- Failure to follow these instructions and warnings can result in serious injury or death.
- Ensure that the Arra pram is correctly assembled, and all features are functioning properly before each use.
- Always use the safety features of your pram such as the harness, tether strap and brakes.
- Your Arra pram is compatible with LIINII seat unit and bassinet (sold separately). It also has Metro Maxi-Cosi adaptors (sold separately) which can be used with Maxi-Cosi car capsules.
- There may be some slight variations in the design of your product to what is shown in the images of this instruction manual.

## WARNING: TO AVOID INJURY OR DEATH

- Never leave your child unattended
- Always apply the parking brake when the Arra pram is stationary and far away from hazards.
- Always use the five-point safety harness to strap your baby firmly into the seat. This will help prevent the risk of your child falling/sliding out or getting strangled by the loose straps.
- Never leave the harness connected when not fitted to a child as it can form loops which may cause a strangulation hazard.
- Always use tether strap to stop the Arra pram from rolling away.
- Keep children away from moving parts when folding and unfolding Arra pram, otherwise they may be injured.
- This pram is not suitable for running or skating.
- Do not let your child or other children play with the Arra pram. Climbing or leaning on the pram can cause it to tip over and cause serious injuries or worse.
- We recommend you do not use Arra pram on escalators and stairs as this may be dangerous.

- Do not leave the rain cover on without the ventilation window open as this can pose a risk of overheating and suffocation.
- Arra is designed for use on flat or gentle sloping surfaces and may be unstable on higher sloping and uneven surfaces. The vehicle may tip over when used incorrectly on steep inclines/declines. Take extra care when going up/down a curb, or other uneven surfaces.
- Never pick up the Arra pram by the carry handle while your child is in the bassinet or seat.
- Never use the bassinet or seat to transport your child in a car.
- Do not put a pillow, quilt or extra padding in the bassinet as this can become a suffocation hazard. The child can roll over and suffocate on soft surfaces caused by extra padding.
- Never leave a sleeping child unattended in the bassinet. The Arra bassinet is not a substitute for a cot bed. The child can become trapped between parts of the bassinet and get strangled or suffocated.
- To prevent the risk of the pram catching fire, do not use it near open fire or exposed flames or extreme heat.
- Dispose any plastic wrapping and packaging materials immediately after unpacking as they can lead to choking hazard.
- Arra pram is designed for one child only.
- For the safety of your child, do not use your Arra pram with any other products or accessories not recommended by LIINII as they may not be compatible.
- Do not exceed recommended weight of the pram by carrying extra children and also exceeding basket weight as this can make the pram unstable causing it to tip over.
- Never hang bags on the handlebar as it can tip the pram over.

## RECOMMENDED WEIGHT AND AGE LIMIT

- Maximum weight limit for a child in the Arra bassinet is 9kg.
- Maximum weight for a child in the seat unit is 22kg.
- Maximum weight for items in the Arra basket is 9kg.
- Arra pram seat unit is suitable for a child from 0 to 36 months. We recommend you keep newborn babies less than 6 months old on fully reclined position of the seat unit.

- The bassinet is suitable only for a child that cannot sit unaided, roll over and cannot push up on hands and knees. It is not intended for use by children older than 6 months or who can sit unaided.

## PRAM MAINTENANCE

- Arra pram requires regular maintenance by the user.
- Before each use, check that no parts on the Arra pram are damaged, worn out or missing.
- If there is an issue, repair or replace immediately.
- If the Arra pram is dirty, use a soft towel or sponge and lukewarm water to gently clean or rub off any dirt. Use a dry cloth to wipe any excess water on handlebar and chassis.
- The bassinet and seat fabrics are detachable.
  - Do not use washing machine
  - Do not use bleach or detergents
  - Do not tumble dry
  - Do not iron
  - Do not dry clean
- If wet, dry the bassinet and/or seat fabrics in well-ventilated place without exposing them to too much sunlight for long periods.
- Store your Arra pram and its accessories in a dry place to prevent mould.
- Use a brush and water to clean dirt on the wheels. Regularly, remove the wheels from the chassis and brush off any dirt or sand in the inside axle of the wheel.
- Use a soft brush to carefully clean sand and dirt from the mechanisms and sliding tubes of the chassis.

## Baby stroller assembly drawing

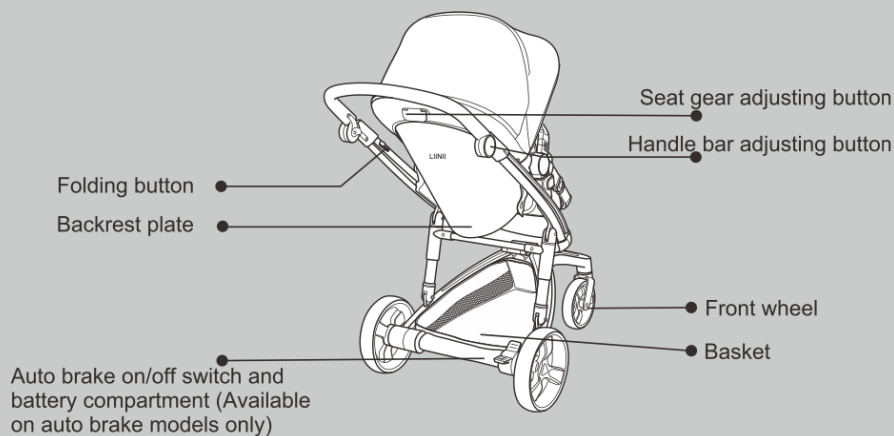
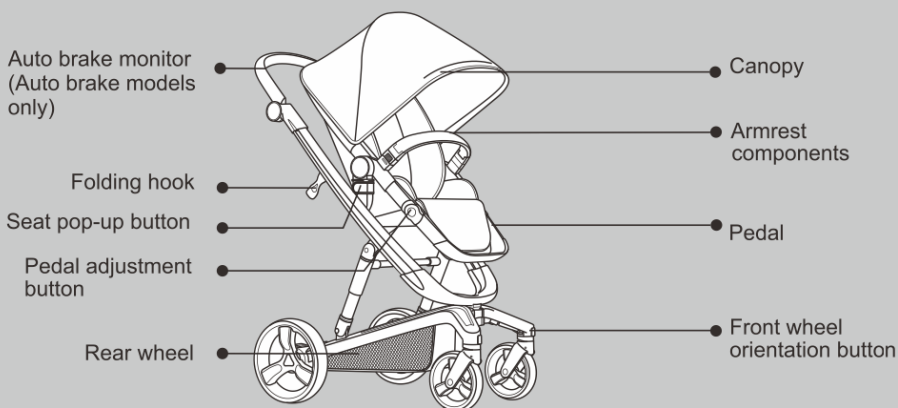

# Installation of the frame

## 1. Unfolding the frame

- i. Firstly, open the collapse lock on the side of the frame.
- ii. Gently pull up the handlebar upwards until the frame locks into place. When the frame is fully opened you will hear a 'click' sound.
- iii. Press the button on the side of the handlebar to adjust its height as required.

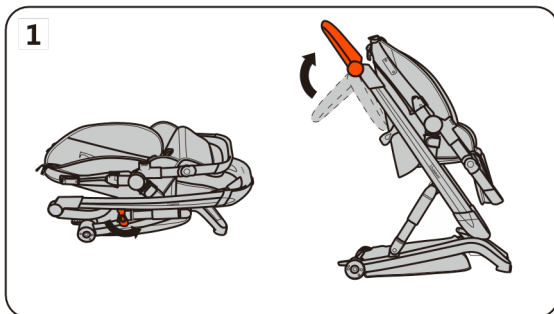

## 2. Installing the rear wheel:

- i. Lift up the rear axle housing located at the back of the pram frame and fully insert the rear wheel until you hear a "click" sound. That means the rear wheel is installed well. Use the same way to install another rear wheel.

### Removing the rear wheel:

- i. Press the rear wheel button on the bottom of the rear axle housing to release the wheel and pull outwards to remove.

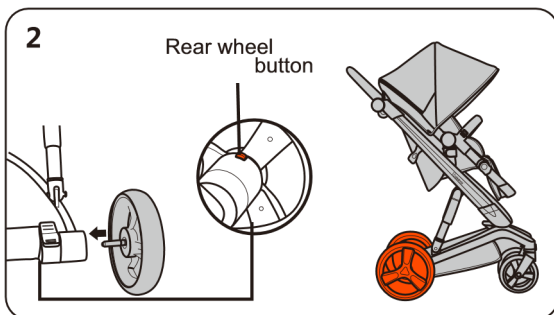

## 3. Installing the front wheel:

- i. Lift up the front wheel axle housing located at the front of the pram frame and fully insert the front wheel until you hear a "click" sound. That means the front wheel is installed well. Use the same way to install another front wheel.

### Removing the front wheel:

- i. Press the front wheel button on the bottom of the front axle housing to release the wheel and pull outwards to remove.

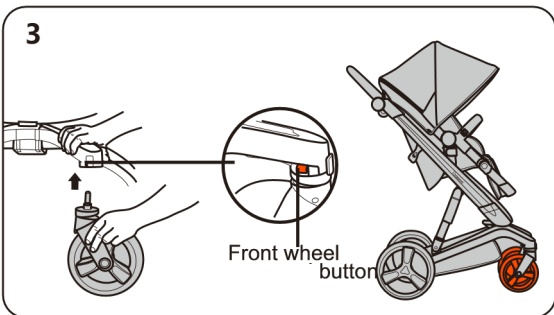

# Use of pram armrest and canopy

## 4. Installing and disassembling armrest components:

- i. Take the armrest components and insert them into the socket one by one. To remove just press the button and pull up the armrest.

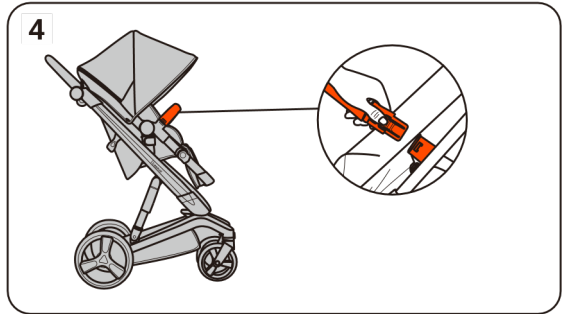

## 5. Installing the canopy:

- i. Before you install the canopy, you should distinguish the inside and outside of the canopy brackets. Then insert the bracket clips onto each side of the pram frame.
- ii. Penetrate the canopy bracket twig in the canopy cover. Then put the twig aim at the canopy bracket base and insert it in the base.
- iii. At last, hang the lock hole at the bottom of canopy on hanging column.

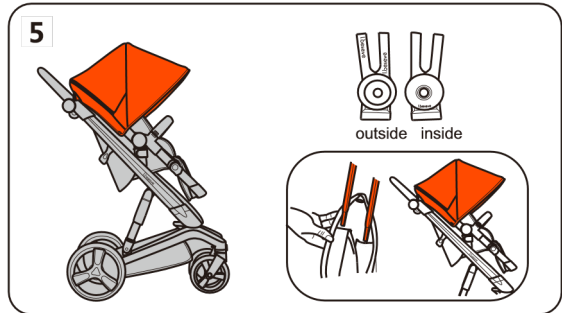

## 6. Using the canopy:

- i. Open the canopy by pulling forward or close by pushing it backward.
- ii. To access the peek a boo window on the canopy, lift the cover & place over the centre bow.

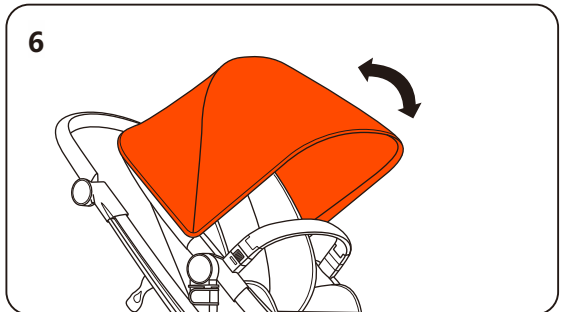

## 7. Reclining the seat

- i. Fully lift the hand recline lever upwards towards the canopy, and lower or raise the seat into the desired position.

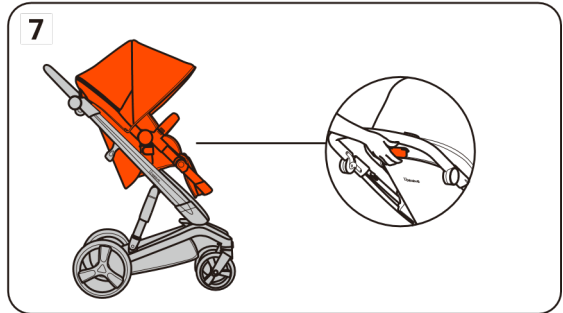

## ! WARNING

THE UPRIGHT AND SEMI-RECLINED POSITIONS ARE NOT RECOMMENDED FOR A CHILD UNDER 6 MONTHS OLD. NEWBORNS SHOULD RIDE ONLY IN THE FULLY RECLINED POSITION.

## 8. Reversing the seat – parent and forward facing positions

- i. Remove the seat unit by pushing the connectors located on either side of the seat unit inwards and lift the seat upwards. The seat unit can be fitted on either parent or forward-facing positions.

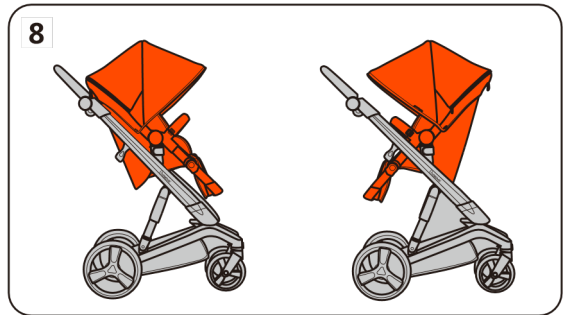

## ATTENTION:

DO NOT REVERSE THE SEAT WHEN A CHILD IS IN THE SEAT.



## 9. Using the 5-Point Safety Harness:

i. Insert the shoulder and waist straps into the centre buckle individually and click backwards to secure. You will hear a firm 'click' when each strap is secured.

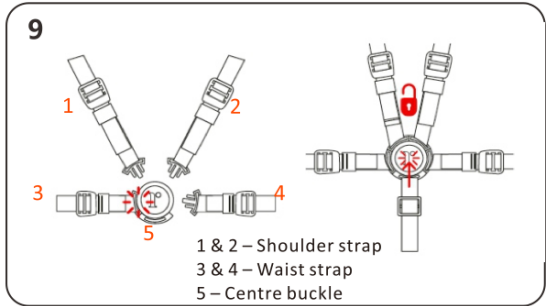

## 10. Adjusting the footrest:

i. Using two hands, press the buttons on both sides of footrest and then adjust the footrest downwards or upwards into the desired position. A 'click' sound assures you that the footrest is into position.

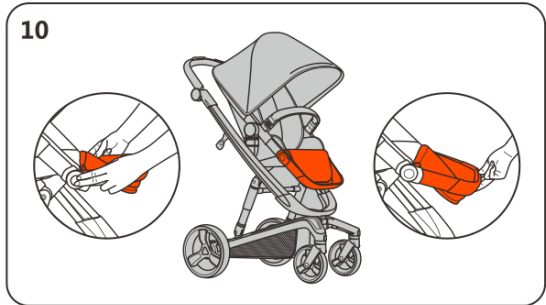

## 11. Locking the front swivel wheels

i. Straightened the front wheels facing forward. Slide downwards on the buttons located on top of the front wheel housing until you hear and feel a 'click' to lock and settled.

ii. To unlock, simply pull the button upwards. When released successfully, you will hear and feel a 'click'.

The front wheels will again spin 360 degree smoothly.

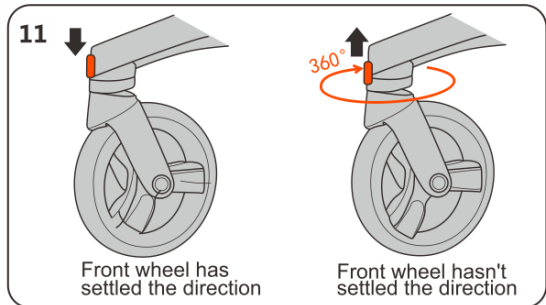

## ATTENTION:

TO PREVENT THE WHEELS FROM SLIPPING, LOCK THE FRONT WHEEL WHEN YOU PARK THE STROLLER ON TILTED ROADS.

## 12. Engaging and releasing the brake:

- i. To engage the brake, press downwards and backwards on the red brake located next to the right rear wheel until you feel and hear a 'click'.
- ii. To release the brake, press your foot forwards on the brake in the opposite direction until the brake lock disengages.

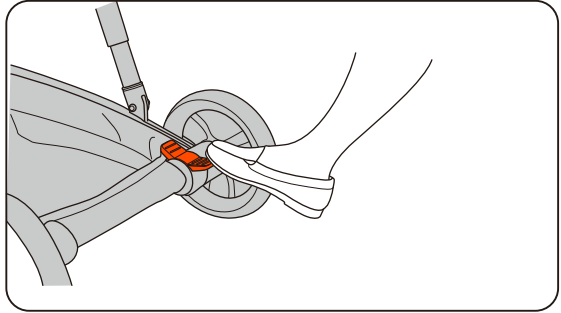

### Auto brake prams only:

- i. Left of the foot manual brake is where you find

the auto brake on/off switch button, charging USB port and battery compartment.

- ii. Once the handlebar auto brake function light comes on, hold the handlebar raised grip area with both hands and squeeze gently to disengage the auto brakes.
- iii. Release your hands from the pram handle grip areas and the pram auto brakes will lock the back wheels automatically. See if the activated brake light is still showing the lock brake symbol. Gently push or pull the pram to ensure the auto brake is fully engaged.

Battery power on a full charge last for one month when in use regularly.

## ATTENTION:

BEFORE PARKING THIS PRAM OR TAKING THE CHILD IN OR OUT OF THE PRAM, YOU MUST STEP ON THE BRAKE PEDAL.

**NOTE:** AUTO BRAKE IS AN ADDITIONAL SAFETY FEATURE AND SHOULD BE USE AT ALL TIMES IN CONJUNCTION WITH MANUAL BRAKE.

### 13. Removing the seat cushion:

#### cushion:

- i. Unlock the 5-point safety harness by pressing the button in the middle of the centre buckle. Then pull out the shoulder, the waist straps and centre buckle and remove the cushion.

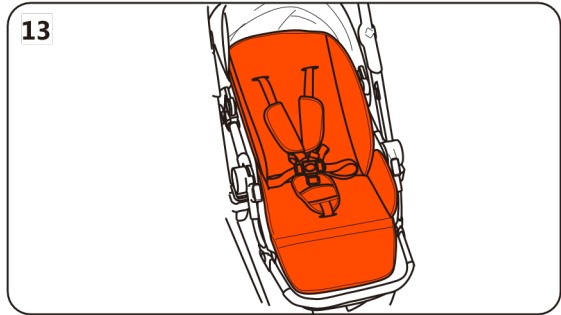

### 14. Folding frame

- i. Remove the bassinet (if using bassinet) or change the seat to forward facing and fully upright position before folding the frame.
- ii. With your hands on both left and right side of the frame, slide the frame fold latch upwards towards you.
- iii. Gently fold the frame forwards and down toward the ground.
- iv. Lock on the folding hook.

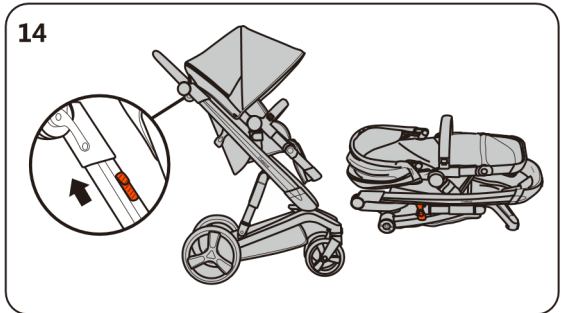

### Unfolding frame

- i. Release the frame lock on the side of the frame
- ii. Gently lift the handlebar upwards, continuing until the frame locks into place and you will hear a 'click' sound.

## ATTENTION:

IF YOU WANT THE FOLDED FRAME TO BE MORE COMPACT, YOU CAN REMOVE THE FRONT AND REAR WHEELS.

### 15. Using the tether strap

- i. Always attach the tether strap to your wrist when using the pram.

## WARNING

USE THIS STRAP TO STOP THE PRAM/PRAM\* ROLLING AWAY.

This manual is suitable for all LIINII Manual Brake and Auto Brake (AB) Models.  
LIINII Models: JIR-0001, JIL-0001, JIK-0001 and JIR-0001AB, JIL-0001AB, JIK-0001AB

## **WARRANTY POLICY**

In this Warranty Agreement document " We", "Our", "Site(s)" and "Us" refers to "Liinii", "www.liinii.com.au" or any LIINII social media sites or platforms where we operate.

### **36 Months Australian Manufacturer Warranty**

All prams come with two years manufacturing warranty on the pram frame, chassis and non-removable parts. Accessories for prams come with a year manufacturing warranty.

The warranty period starts from the date that your pram is dispatched from our warehouse and is valid in Australia only.

### **The warranty is not valid and does not cover in the following cases:**

- Defects or faults resulting from improper assembly, care or use as outlined in our user manual.
- Defects or faults resulting from an accident, airline or transport damage.
- Normal wear and tear, including scratches to the frame or colour fading of the fabrics.
- Minor cosmetic scratches or blemishes resulting from shipping.
- Damage to handle/belly bar grips or fabrics (i.e. scuffs or tears) as a result of normal handling and daily use.

- ❑ Corrosion, mould or rust due to extreme environmental conditions, including high humidity, salt spray, snow or due to lack of regular maintenance;
- ❑ Products that are purchased second hand or from an unauthorised distributor.
- ❑ Using a part or accessory that is not compatible with the product and/or not manufactured or recommended by LIINII Prams.
- ❑ If you or a third party has attempted to modify or repair the pram without having received written permission from LIINII Prams.
- ❑ Claims from anyone other than the original purchaser (i.e. no longer valid if you gift or sell to your sibling or friend);
- ❑ Damage resulting from extreme heat conditions (i.e. leaving in a car on hot days).
- ❑ Customer dissatisfaction with the product in terms of fit, weight, functionality, colour or design.
- ❑ Inner tube tyre punctures, tyre bulges or broken air valves.
- ❑ Defects to the product caused by accident, neglect, misuse or 'Act of God'.

### **What if I need to make a claim?**

1. Contact us by email at [enquiries@liinii.com.au](mailto:enquiries@liinii.com.au) and we will respond and start your warranty claim within three business days of receiving your warranty request.
2. Include your order number, a detailed description and photo or video of the defect or problem.
3. Our warranty team will then determine the best way to resolve any defects or faults. LIINII reserves the right to repair, exchange or replace the damaged item with a replacement part in cases minor defect. Some parts may be replaced with newer model parts as the pram is improved over time.

NOTE: This warranty is an additional benefit to your legal and consumer rights under the Australian Competition and Consumer act 2010, or Australia Consumer Law also known as ACL.

By purchasing a LIINII product means you are agreeing to our warranty agreement and all other LIINII policies, terms and conditions stated thereof by us.

### Australian Consumers

This warranty does not infringe on your legal rights and your rights under the Australian Consumer Law. Our goods come with guarantees that cannot be excluded under the Australian Consumer Law. You are entitled to a replacement or refund for a major failure and for compensation for any other reasonably foreseeable loss or damage. You are also entitled to have the goods repaired or replaced if the goods fail to be of acceptable quality and the failure does not amount to a major failure.

LIINII prams and strollers comply with Australia and New Zealand standards AS/NZS 2088:2000

Please keep this warranty guide in a safe place



LIINII

LIINII Group Pty Ltd, ABN 68 624 588 290

148A Albany Street, Point Frederick, NSW 2250, Australia

Email: [enquiries@liinii.com.au](mailto:enquiries@liinii.com.au)