

ENDEAVOR™



A I R H A N D L E R G U I D E



Rheem.com/Endeavor

Rest easy with quiet, **Efficient Comfort**

Enjoy cool summer days, cozy winter nights and everything in between with the Rheem® Endeavor™ Line of Air Handlers. Offering high efficiency and quiet operation, Rheem Endeavor Air Handlers make it simple to relax in affordable, dependable comfort—year-round.



High Performance Meets Long-lasting Quality



PEACE-OF-MIND PERFORMANCE

Relax, you're covered by some of the best warranties in the industry¹—up to 10 Year Limited Parts².



QUIET OPERATION

Sound levels range from quietest to quiet with insulated cabinets and truly variable speed airflow technology³—giving you one of the quieter air handler lines available⁴.



OPTIMAL COMFORT

Modulating⁵ (between 40% and 100% of capacity), three-stage⁶ (high, medium, low) or two-stage (high, low) heating operation⁷, along with variable speed motor technology³, ensures a steady stream of just-right heated airflow to maintain your comfort level preference while providing superior humidity control.



EcoNet[®]



The Rheem Endeavor Line RHMVZ****C, RH3VZ and RH2VZ operate with the easy-to-use EcoNet Smart Thermostat, which optimizes system performance and provides a new level of protection and precision comfort **with features like:**

- Communication with latest sensor technology
- Control of your thermostat from anywhere via the EcoNet App⁸
- Alerts sent directly to your phone or email



Simplified Install & Service with Bluetooth Technology

Built-in Bluetooth connectivity⁹ makes it faster and easier for your contractor to install and service your new system. This can help lower your costs and help make your home comfortable again—fast.



TESTED. TRUSTED. TOUGH.

From the smallest part to complete comfort systems, we build quality into everything we make so we can be sure it's tough enough to deliver the ultimate performance you can count on day after day, year after year. That reliability is what makes Rheem different—and better.



We Thought of Everything... & Then Some

We evaluate every detail of a product from top to bottom, inside and out and every angle in between. That's 360+1. And that's why you can count on Rheem Endeavor Air Handlers to bring you and your family years of efficient and dependable indoor comfort.



Rheem® Endeavor™ Line Air Handlers



	RHMVZ****C	RH3VZ	RH2VZ	RH2TZ
Motor	Constant CFM	Constant CFM	Constant CFM	Constant Torque
Airflow Stages	Modulating	Three-Stage	Two-Stage	Two-Stage
Expansion Device	Electronic Expansion Valve (EEV)	Thermal Expansion Valve (TXV)	Thermal Expansion Valve (TXV)	Thermal Expansion Valve (TXV)
Efficiencies	18+ SEER2	15 – 17 SEER2	13.4 – 14.3 SEER2	13.4 – 14.3 SEER2
Sound Ranking⁴	Quietest	Quietest	Quieter	Quiet
EcoNet Enabled	Yes	Yes	Yes	No
Bluetooth Connectivity⁹	Yes	Yes	Yes	No
Feature Highlights	Rheem Contractor and EcoNet Apps ⁸ , built-in EcoNet and Bluetooth technology allows for easy install and diagnostics	Rheem Contractor and EcoNet Apps ⁸ , built-in EcoNet and Bluetooth technology allows for easy install and diagnostics	Rheem Contractor and EcoNet Apps ⁸ , built-in EcoNet and Bluetooth technology allows for easy install and diagnostics	
Configuration	4-Way Convertible	4-Way Convertible	4-Way Convertible	4-Way Convertible
Height	42.5 – 57 in. (varying sizes)	42.5 – 57 in. (varying sizes)	42.5 – 57 in. (varying sizes)	42.5 – 57 in. (varying sizes)
Compatible Thermostat	EcoNet Smart Thermostat — Two-Stage 24V (Emergency Only)	EcoNet Smart Thermostat — Two-Stage 24V (3-Stage Operation Only)	EcoNet Smart Thermostat — Two-Stage 24V	Two-Stage 24V — Single-Stage 24V
Limited Warranty¹	Parts – 10 Years	Conditional Parts – 10 Years (registration required)	Conditional Parts – 10 Years (registration required)	Conditional Parts – 10 Years (registration required)

Continued

	RH1PZ	RF2TZ	RF1PZ	RB2TZ
Motor	PSC	Constant Torque	PSC	Constant Torque
Airflow Stages	Single-Stage	Two-Stage	Single-Stage	Two-Stage
Expansion Device	Thermal Expansion Valve (TXV)	Thermal Expansion Valve (TXV)	Thermal Expansion Valve (TXV)	Thermal Expansion Valve (TXV)
Efficiencies	13.4 – 14.3 SEER2	13.4 – 14.3 SEER2	13.4 – 14.3 SEER2	13.4 – 14.3 SEER2
Sound Ranking⁴	Quiet	Quiet	Quiet	Quiet
EcoNet Enabled	No	No	No	No
Bluetooth Connectivity⁹	No	No	No	No
Feature Highlights				
Configuration	4-Way Convertible	Front / Bottom	Front / Bottom	4-Way Convertible
Height	42.5 – 57 in. (varying sizes)	36 in. (all sizes)	36 in. (all sizes)	35 in. (all sizes)
Compatible Thermostat	Two-Stage 24V — Single-Stage 24V	Two-Stage 24V — Single-Stage 24V	Two-Stage 24V — Single-Stage 24V	Two-Stage 24V — Single-Stage 24V
Limited Warranty¹	Conditional Parts – 10 Years (registration required)	Conditional Parts – 10 Years (registration required)	Conditional Parts – 10 Years (registration required)	Conditional Parts – 10 Years (registration required)



Rheem.com

Nearly 100 Years of Innovation

As the only brand bringing innovative air and water solutions to homes and businesses around the world, Rheem continues to deliver advanced comfort, savings and experiences to our customers—just as we've done for nearly 100 years.



Rheem USA

5600 Old Greenwood Road
Fort Smith, Arkansas 72908



Rheem Canada Ltd. / Ltée

125 Edgeware Road, Unit 1
Brampton, Ontario L6Y 0P5

In keeping with its policy of continuous progress and product improvement, Rheem reserves the right to make changes without notice.

¹Registration is required for the conditional parts and unit replacement warranty (if applicable). For complete details of the limited and conditional warranties, including applicable terms and conditions, contact your local Contractor or go to Rheem.com for a copy of the product warranty certificate. ²Refer to the chart for specific warranty terms by product. ³Applies to RHMV****C, RH3VZ and RH2VZ models. ⁴Based on manufacturer's product offering, and the product's heating stages, motor type and cabinet insulation. Sound levels are also dependent on unit location and installation. ⁵Applies to the RHMV****C model. ⁶Applies to RH3VZ model. ⁷Applies to RH2VZ, RH2TZ, RF2TZ and RB2T models. ⁸WiFi broadband internet connection required. Download the EcoNet® App from the App Store® or Google Play® to set up your EcoNet Smart Thermostat. Receipt of notifications depend on home WiFi set up. Amazon, Alexa and all related logos are trademarks of Amazon.com, Inc. or its affiliates. ⁹Applies to RHMV****C, RH3VZ and RH2VZ models.





The new degree of comfort.®

Endeavor™ Line Air Handlers



RB2TZ

Constant Torque Motor (ECM)
Two Stage Airflow
Efficiencies: 13.4 - 14.3 SEER2



Table of Contents

Features & Benefits	3
Model Number Identification	4
Model Numbers.....	4
Dimensional Data	5
Unit Dimensions & Weights.....	6
Airflow Directional Data.....	7
Airflow Performance Data	8-12
Electrical Data	13-14
Limited Warranty	16

Features and Benefits

- **Quiet Operation¹:** Provided by a cabinet construction with 1.0 inch foil faced insulation for quieter sound characteristics
- **Rugged Steel Cabinet Construction:** Designed for added strength and versatility
- **Compact Design and 4-Way Field Convertible Design:** Stands at only 35" tall and convertible options include vertical upflow, vertical downflow, horizontal left hand or right hand air supply
- **Field-installed Auxiliary Heater Kits:** Provide exact heat for indoor comfort and include circuit breakers which meet UL and cUL requirements for service disconnect
- **Less than 2% Cabinet Air Leakage at 1-inch H₂O:** When tested in accordance with AHRAE standard 193

¹Based on manufacturer's air handler offering, and the product's airflow stages, motor type and cabinet insulation. Sound levels are also dependent on air handler location and installation.

Air Handlers

<u>R</u>	<u>B</u>	<u>2</u>	<u>T</u>	<u>Z</u>	<u>24</u>	<u>17</u>	<u>S</u>	<u>T</u>	<u>A</u>	<u>N</u>	<u>M</u>	<u>A</u>	<u>B</u>	<u>0</u>
Brand	Product Category	Stages Of Airflow	Motor Type	Refrigerant	Capacity	Width	Efficiency	Metering	Major Series	Controls	Coil Series	Voltage	Disconnect	Factory Heat
R - Rheem	B - Low Boy 34"	2 - 2-Stage	T - Constant Torque	Z - R-410A	24 - 24,000 [7.03 kW] 36 - 36,000 [10.55 kW] 48 - 48,000 [14.07 kW] 60 - 60,000 [17.58 kW]	17 - 17.5" 21 - 21" 24 - 24.5"	S - Standard	T - TXV	A - 1st Design	N - Non-Communicating	M - Multiflex	A - 115/1/60 J - 208-240/1/60	B - Breaker N - None	0 - No Heat 3 - 3 kW 5 - 5 kW 7 - 7 kW 10 - 10 kW

[] Designates Metric Conversions

Model Number
RB2TZ2417STANMJB05
RB2TZ2417STANMJB07
RB2TZ2417STANMAN00
RB2TZ3621STANMJB05
RB2TZ3621STANMJB07
RB2TZ3621STANMJB10
RB2TZ3621STANMAN00
RB2TZ4824STANMJB05
RB2TZ4824STANMJB07
RB2TZ4824STANMJB10
RB2TZ4824STANMAN00
RB2TZ6024STANMJB10
RB2TZ6024STANMAN00

Standard Equipment
Compact Unit Design
Quiet, efficient ECM Motor provides nominal airflow to 0.58 inch [12 kPa] of external static pressure
Field selectable airflow
Low continuous fan speed
Rugged steel cabinet construction 1" foil faced insulation
Four leg rubber insulated wire motor mount
Circuit breakers are standard on all electric heat models
Provisions for field electrical connections from both sides of cabinet
Slide out blower design for easy service & maintenance
Tab lock blower housing with integrated electric heaters, controls, motor and blower

Unit Dimensions

NOTE: 24" CLEARANCE REQUIRED IN FRONT OF UNIT FOR FILTER AND COIL MAINTENANCE.

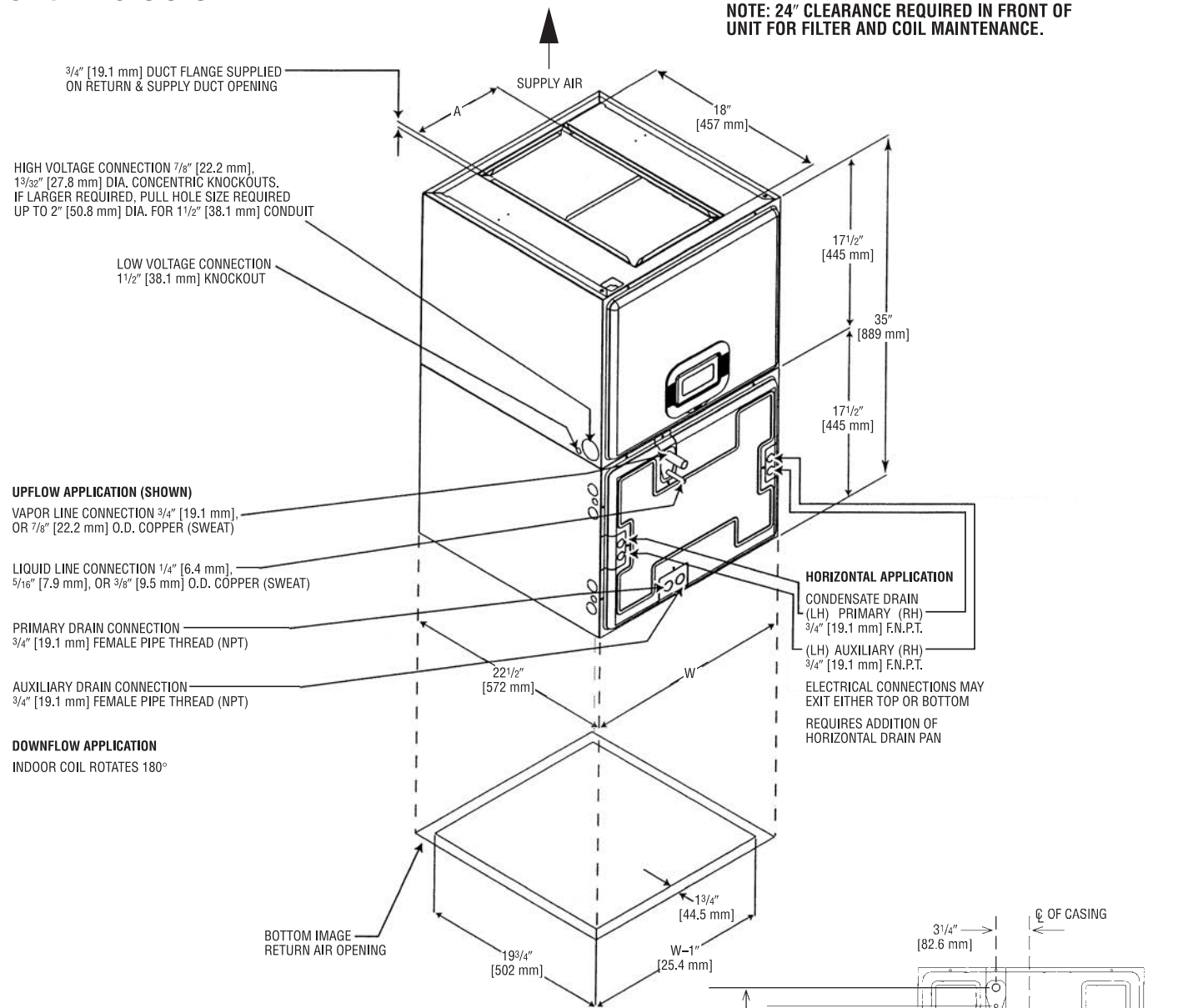

**UPFLOW UNIT (WITH COIL) SHOWN:
 UNIT MAY BE INSTALLED UPFLOW, DOWNFLOW,
 HORIZONTAL RIGHT OR LEFT HAND AIR SUPPLY.**

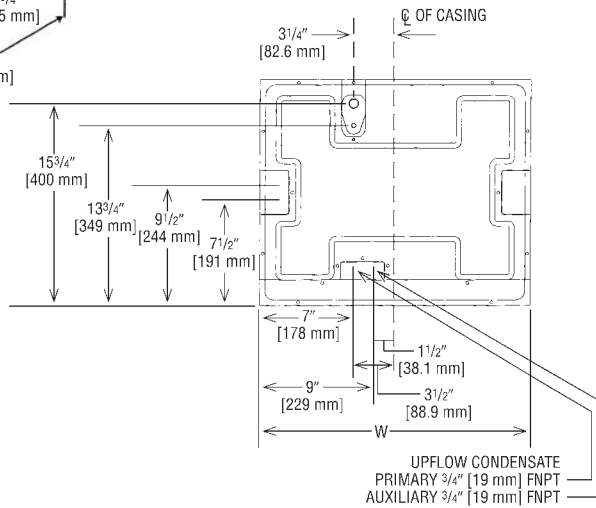

Return Air Opening Dimensions

Model Cabinet Size	Return Air Opening Width (Inches)	Return Air Opening Depth/Length (Inches)
17	15 7/8	19 3/4
21	19 3/8	19 3/4
24	22 7/8	19 3/4

[] Designates Metric Conversions

Unit Dimensions & Weights

Model Cabinet Size	Unit Width "W" In. [mm]	Supply Duct "A" In. [mm]	Unit Weight/Shipping Weight (Lbs.) [kg]
RB2TZ2417ST	17 ¹ / ₂ [445]	7 ⁹ / ₁₆ [192]	92/99 [42/45]
RB2TZ3621ST	21 [533]	9 ⁷ / ₁₆ [240]	109/117 [49/53]
RB2TZ4824ST	24 ¹ / ₂ [622]	11 ³ / ₄ [298]	125/134 [57/61]

[] Designates Metric Conversions

Airflow Directional Data

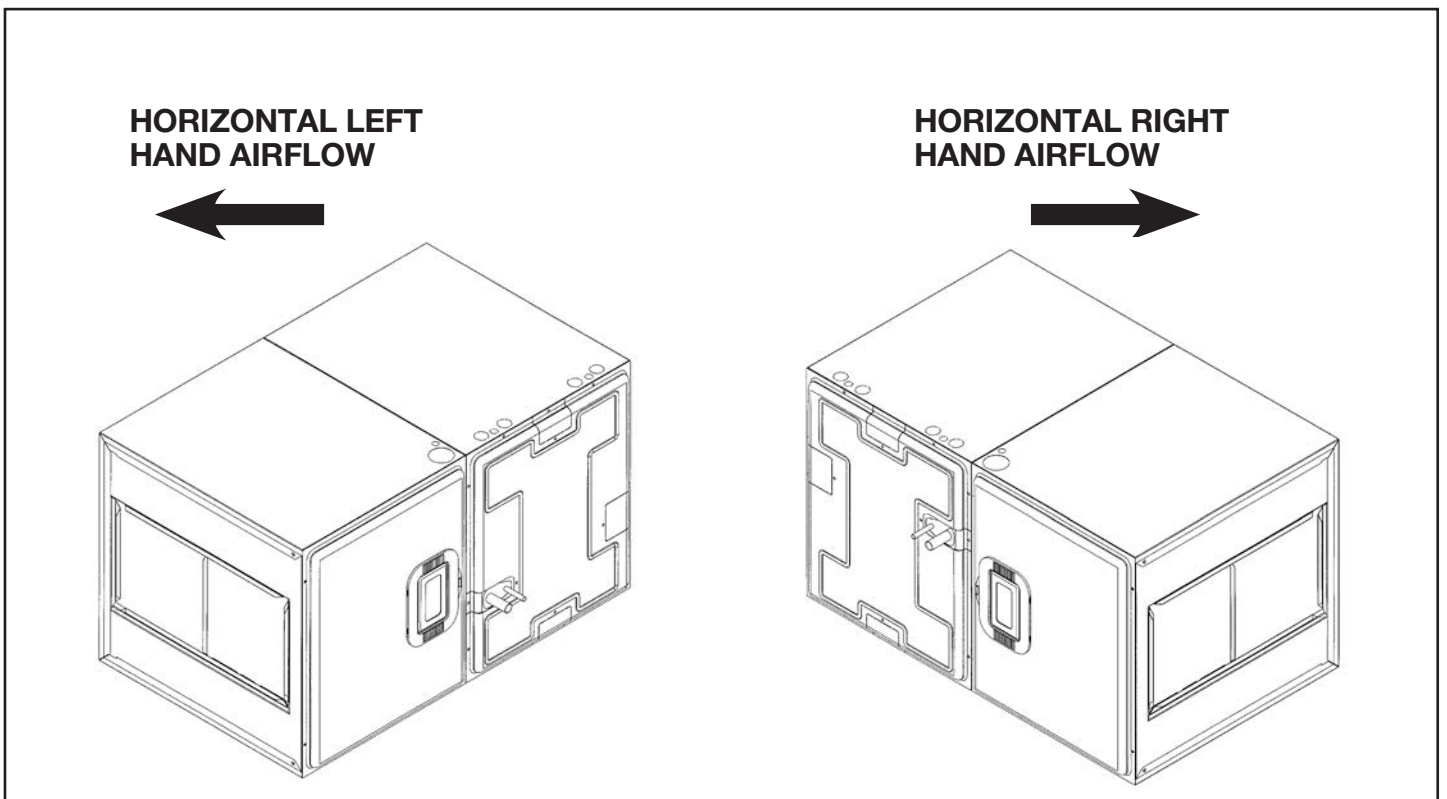
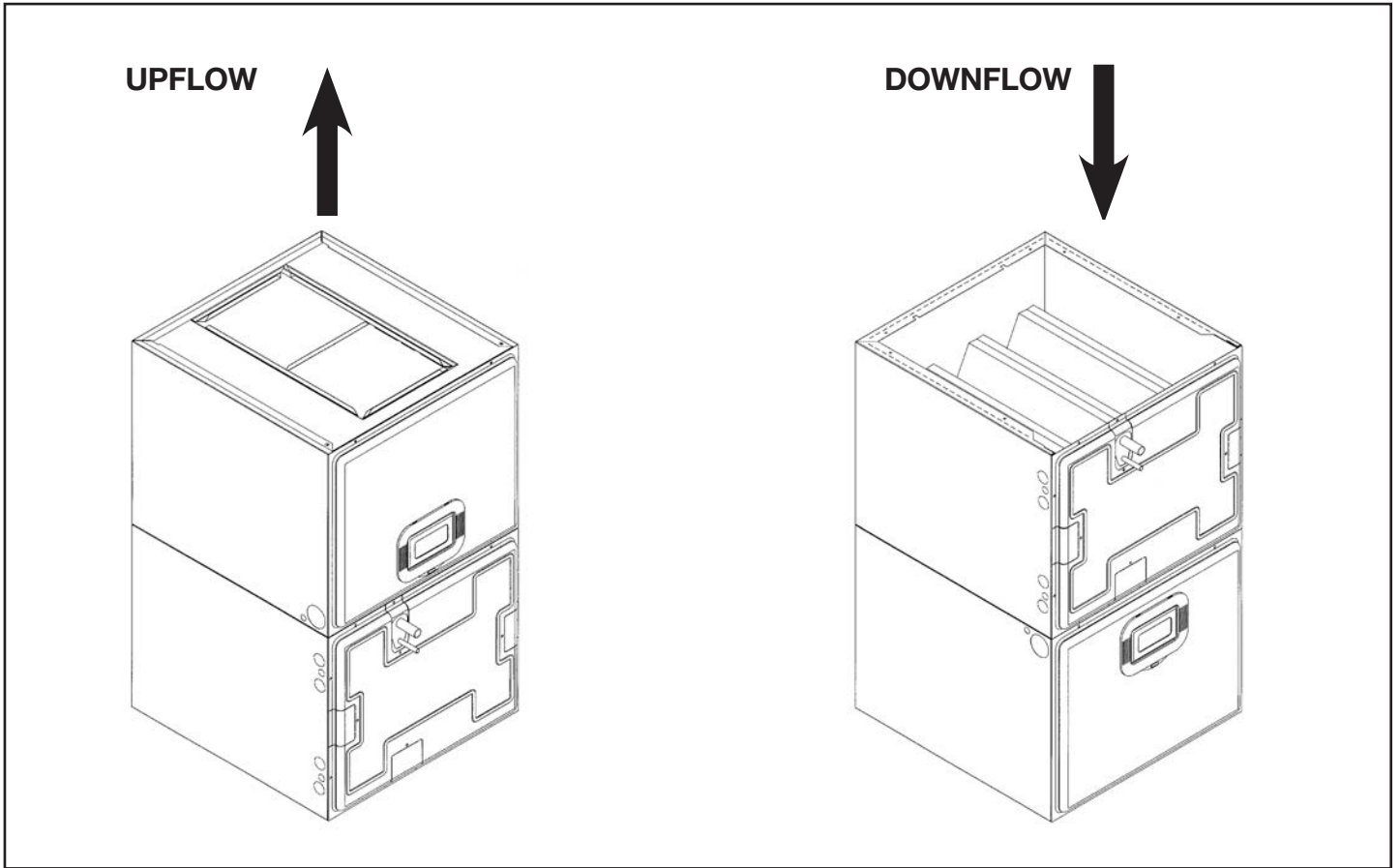

NOTE: Coil and blower section are always in a draw through configuration.

Airflow Performance

Airflow performance data is based on cooling performance with a coil and no filter in place. Select performance table for appropriate unit size, voltage and number of electric heaters to be used. Make sure external static applied to unit allows operation within the minimum and maximum limits shown in

table below for both cooling and electric heat operation. For optimum blower performance, operate the unit in the .3 [8 mm] to .7 inches [18 mm] W.C. external static range. Units with coils should be applied with a minimum of .1 inch [3 mm] W.C. external static range.

General Airflow Operating Limits

Model Cabinet Size	17		21		24		24	
Cooling BTUH Cooling Tons Nominal	18,000 1.5	24,000 2	30,000 2.5	36,000 3	42,000 3.5	48,000 4	60,000 5	60000 5
Heat Pump or Air Conditioning Maximum Heat/Cool CFM (37.5 CFM/1,000 BTUH) (450 CFM/Ton Nominal)	675	900	1125	1350	1575	1800	2025	2250
Heat Pump or Air Conditioning Nominal Heat/Cool CFM (33.3 CFM/1,000 BTUH) (400 CFM/Ton Nominal)	600	800	1000	1200	1400	1600	1800	2000
Heat Pump or Air Conditioning Minimum Heat/Cool CFM (30.0 CFM/1,000 BTUH) (360 CFM/Ton Nominal)	540	720	900	1080	1260	1440	1620	1800
Maximum kW Electric Heating & Minimum Electric Heat CFM	11 560	11 560	11 900	11 1220	18 1220	18 1220	18 1460	18 1460
Maximum Electric Heat Rise °F	85	85	35	35	65	65	43	43

115V/208V/240V Airflow Performance Data—RB2TZ (Constant Torque (ECM) Motor)

Model			Blower Motor			External Static Pressure—Inches W.C. [kPa] with filter & indoor coil									
Cabinet Size	Tonnage	Heaters	Electric Nominal Speed Tap	Voltage		0.1 [.02]	0.2 [.05]	0.3 [.07]	0.4 [.10]	0.5 [.12]	0.6 [.15]	0.7 [.17]	0.8 [.20]	0.9 [.23]	1.0 [.25]
-17	1.5 Ton	none	2	208/240	CFM	—	519	476	433	391	348	301	257	181	120
					WATTS	—	52.8	57.1	61.5	66.3	71.7	76.7	80.1	84.0	86.4
		none	3	208/240	CFM	—	720	689	656	623	591	559	526	495	463
					WATTS	—	99.3	104.5	109.8	115.4	120.8	126.2	132.1	138.5	145.1
		3 (max)	2	208/240	CFM	—	509	466	423	381	338	291	247	171	110
					WATTS	—	47.8	52.1	56.5	61.3	66.7	71.7	75.1	79.0	81.4
	3 (max)	3	208/240	CFM	—	710	679	646	613	581	549	516	485	453	
				WATTS	—	94.3	99.5	104.8	110.4	115.8	121.2	127.1	133.5	140.1	
	none	2	115	CFM	—	550	509	468	429	390	347	255	303	183	
				WATTS	—	49.1	54.2	59.1	63.8	68.8	74.5	84.4	80.4	88.3	
	none	3	115	CFM	745	712	678	645	613	581	548	517	488	451	
				WATTS	92.9	98.8	105.6	111.6	117.6	123.3	129.1	135.5	141.3	149.3	
	2.0 Ton	none	4	208/240	CFM	—	602	563	525	490	452	414	374	334	292
					WATTS	—	68.6	73.3	78.0	82.4	87.4	93.3	99.4	105.1	108.6
		none	5	208/240	CFM	—	—	845	818	792	764	735	707	680	654
					WATTS	—	—	158.4	164.5	170.7	176.9	183.9	190.7	197.0	203.6
		3 (max)	4	208/240	CFM	—	592	553	515	480	442	404	364	324	282
					WATTS	—	63.6	68.3	73.0	77.4	82.4	88.3	94.4	100.1	103.6
3 (max)		5	208/240	CFM	—	—	835	808	782	754	725	697	670	644	
				WATTS	—	—	153.4	159.5	165.7	171.9	178.9	185.7	192.0	198.6	
none		4	115	CFM	641	605	567	530	496	460	427	387	349	305	
				WATTS	67.1	72.7	78.5	83.8	88.8	94.6	99.8	106.6	113.2	118.1	
none		5	115	CFM	896	870	840	810	782	754	727	699	674	648	
				WATTS	147.5	154.0	161.9	169.5	176.9	183.9	191.1	197.9	205.2	212.4	

[] Designates Metric Conversions

115V/208V/240V Airflow Performance Data—RB2TZ (Constant Torque (ECM) Motor) (Con't.)

Model			Blower Motor			External Static Pressure—Inches W.C. [kPa] with filter & indoor coil									
Cabinet Size	Tonnage	Heaters	Electric Nominal Speed Tap	Voltage		0.1	0.2	0.3	0.4	0.5	0.6	0.7	0.8	0.9	1.0
						[.02]	[.05]	[.07]	[.10]	[.12]	[.15]	[.17]	[.20]	[.23]	[.25]
-21	2.5 Ton	none	2	208/240	CFM	789	743	699	605	557	497	451	391	322	254
					WATTS	57.9	63.2	68.4	79.0	85.3	91.8	96.8	105.1	110.0	113.2
		none	3	208/240	CFM	1060	1027	994	963	927	894	859	826	793	760
					WATTS	145.7	152.4	160.0	167.5	175.3	182.0	189.5	197.0	204.7	212.4
		3 (max)	2	208/240	CFM	819	773	729	635	587	527	481	421	352	284
					WATTS	67.9	73.2	78.4	89.0	95.3	101.8	106.8	115.1	120.0	123.2
		3 (max)	3	208/240	CFM	1090	1057	1024	993	957	924	889	856	823	790
					WATTS	155.7	162.4	170.0	177.5	185.3	192.0	199.5	207.0	214.7	222.4
		none	2	115	CFM	737	693	650	602	554	492	450	391	325	239
					WATTS	67.4	73.5	79.4	85.5	91.9	99.4	105.2	113.6	120.0	123.7
		none	3	115	CFM	1076	1042	1010	977	944	911	877	841	805	768
					WATTS	158.3	166.3	174.2	182.3	190.2	198.5	206.5	215.0	223.4	232.3
	3.0 Ton	none	4	208/240	CFM	790	749	706	661	617	572	511	474	417	357
					WATTS	72.3	77.9	83.5	88.9	94.7	101.1	108.3	113.0	122.0	127.4
		none	5	208/240	CFM	1197	1171	1143	1114	1086	1057	1025	994	964	934
					WATTS	202.2	209.9	218.3	227.1	235.3	243.8	252.1	260.1	269.1	278.4
		3 (max)	4	208/240	CFM	820	779	736	691	647	602	541	504	447	387
					WATTS	85.3	90.9	96.5	101.9	107.7	114.1	121.3	126.0	135.0	140.4
		3 (max)	5	208/240	CFM	1227	1201	1173	1144	1116	1087	1055	1024	994	964
					WATTS	215.2	222.9	231.3	240.1	248.3	256.8	265.1	273.1	282.1	291.4
		none	4	115	CFM	808	767	738	726	684	640	594	532	493	453
					WATTS	81.6	88.0	92.4	94.3	100.7	107.3	114.1	122.5	128.6	135.9
		none	5	115	CFM	1201	1172	1141	1113	1083	1060	1055	1026	995	963
					WATTS	216.4	224.5	233.9	242.5	251.7	258.9	260.5	269.3	278.6	288.4

[] Designates Metric Conversions

115V/208V/240V Airflow Performance Data—RB2TZ (Constant Torque (ECM) Motor) (Con't.)

Model			Blower Motor			External Static Pressure—Inches W.C. [kPa] with filter & indoor coil									
Cabinet Size	Tonnage	Heaters	Electric Nominal Speed Tap	Voltage		0.1 [.02]	0.2 [.05]	0.3 [.07]	0.4 [.10]	0.5 [.12]	0.6 [.15]	0.7 [.17]	0.8 [.20]	0.9 [.23]	1.0 [.25]
-24	3.5 Ton	none	2	208/240	CFM	901	835	782	731	681	620	565	515	472	420
					WATTS	72.1	80.6	87.7	94.3	100.7	108.1	115.2	121.2	127.0	133.4
		none	3	208/240	CFM	1531	1494	1444	1404	1370	1338	1306	1275	1245	1217
					WATTS	255.3	267.6	284.5	298.6	310.5	322.3	333.7	344.7	354.9	365.2
		3 (max)	2	208/240	CFM	926	860	807	756	706	645	590	540	497	445
					WATTS	92.1	100.6	107.7	114.3	120.7	128.1	135.2	141.2	147.0	153.4
	3 (max)	3	208/240	CFM	1556	1519	1469	1429	1395	1363	1331	1300	1270	1242	
				WATTS	275.3	287.6	304.5	318.6	330.5	342.3	353.7	364.7	374.9	385.2	
	none	2	115	CFM	896	835	783	733	678	632	579	519	481	438	
				WATTS	76.3	85.7	93.6	100.9	108.7	115.6	124.1	132.7	138.9	145.7	
	none	3	115	CFM	1504	1473	1433	1383	1350	1317	1286	1256	1227	1195	
				WATTS	260.9	271.6	286.6	305.5	317.2	329.3	341.9	352.7	363.4	373.6	
	4.0 Ton	none	4	208/240	CFM	1105	1043	998	957	915	875	824	780	737	693
					WATTS	113.0	124.8	133.0	141.1	148.6	155.8	165.4	173.9	181.8	189.6
		none	5	208/240	CFM	1656	1629	1589	1544	1508	1482	1454	1424	1394	1365
					WATTS	322.7	334.3	350.6	369.5	384.9	397.1	409.1	421.8	435.2	447.7
		3 (max)	4	208/240	CFM	1135	1073	1028	987	945	905	854	810	767	723
					WATTS	133.0	144.8	153.0	161.1	168.6	175.8	185.4	193.9	201.8	209.6
3 (max)		5	208/240	CFM	1686	1659	1619	1574	1538	1512	1484	1454	1424	1395	
				WATTS	342.7	354.3	370.6	389.5	404.9	417.1	429.1	441.8	455.2	467.7	
none		4	115	CFM	1119	1061	1016	974	934	884	842	798	756	711	
				WATTS	121.8	134.1	143.6	152.5	161.0	169.9	178.3	187.7	198.0	207.0	
none		5	115	CFM	1655	1625	1593	1544	1512	1479	1451	1423	1396	1369	
				WATTS	342.7	355.7	370.3	392.6	407.4	423.0	436.1	449.5	462.4	475.5	

[] Designates Metric Conversions

115V/208V/240V Airflow Performance Data—RB2TZ (Constant Torque (ECM) Motor) (Con't.)

Model			Blower Motor			External Static Pressure—Inches W.C. [kPa] with filter & indoor coil									
Cabinet Size	Tonnage	Heaters	Electric Nominal Speed Tap	Voltage		0.1 [.02]	0.2 [.05]	0.3 [.07]	0.4 [.10]	0.5 [.12]	0.6 [.15]	0.7 [.17]	0.8 [.20]	0.9 [.23]	1.0 [.25]
-24	5 Ton	none	2	208/240	CFM	1121	1062	1007	950	877	799	693	637	580	514
					WATTS	100.7	110.1	118.7	127.9	138.8	149.5	161.4	168.3	174.8	182.2
		none	3	208/240	CFM	1657	1618	1582	1548	1516	1481	1437	1398	1343	1294
					WATTS	274.5	287.4	300.0	311.9	324.4	336.7	350.7	364.8	382.7	398.4
		3 (max)	2	208/240	CFM	1079	1020	965	908	835	757	651	595	538	472
					WATTS	121	130	139	148	159	169	181	188	195	202
		3 (max)	3	208/240	CFM	1615	1576	1540	1506	1474	1439	1395	1356	1301	1252
					WATTS	295	307	320	332	344	357	371	385	403	418
		none	2	115	CFM	1111	1058	1004	938	874	791	692	626	573	501
					WATTS	104.3	113.1	122.5	134.1	144.3	157.1	168.0	176.0	183.6	191.3
		none	3	115	CFM	1658	1620	1580	1546	1514	1478	1435	1393	1347	1299
					WATTS	283.2	296.8	311.0	323.3	336.4	350.0	365.0	379.8	396.0	412.9
		none	4	208/240	CFM	1226	1179	1131	1080	1022	957	884	778	728	674
					WATTS	125.6	134.5	144.2	153.9	164.7	176.4	188.1	201.9	208.9	217.7
		none	5	208/240	CFM	2010	1977	1944	1917	1887	1860	1838	1809	1787	1760
					WATTS	470.4	485.6	504.6	520.4	537.8	554.0	569.8	587.5	603.5	621.0
		3 (max)	4	208/240	CFM	1184	1137	1089	1038	980	915	842	736	686	632
					WATTS	145.6	154.5	164.2	173.9	184.7	196.4	208.1	221.9	228.9	237.7
3 (max)	5	208/240	CFM	1968	1935	1902	1875	1845	1818	1796	1767	1745	1718		
			WATTS	490.4	505.6	524.6	540.4	557.8	574.0	589.8	607.5	623.5	641.0		
none	4	115	CFM	1213	1161	1110	1060	998	938	848	757	697	653		
			WATTS	126.0	136.1	146.3	156.3	168.3	179.3	194.2	206.3	215.6	222.8		
none	5	115	CFM	2014	1985	1953	1920	1887	1856	1829	1801	1774	1739		
			WATTS	489.5	505.8	524.3	542.5	560.6	578.9	594.6	611.9	629.1	649.3		

[] Designates Metric Conversions

Electrical Data—Blower Motor Only Without Electric Heat

Model Size/Elec. Designation	Voltage	Phase	Hertz	HP [W]	RPM	Speeds	Motor Amps.	Minimum Circuit Ampacity	Maximum Circuit Protector
(-)B2TZ2417STANMAN00	115	1	60	1/3 [249]	300-1100	5	3.3	5.0	15
(-)B2TZ3621STANMAN00	115	1	60	1/2 [373]	300-1100	5	5.0	7.0	15
(-)B2TZ4824STANMAN00	115	1	60	3/4 [559]	300-1100	5	6.4	8.0	15
(-)B2TZ6024STANMAN00	115	1	60	3/4 [559]	300-1100	5	8.5	11.0	15

Model Size/Elec. Designation	Voltage	Phase	Hertz	HP [W]	RPM	Speeds	Motor Amps.	Minimum Circuit Ampacity	Maximum Circuit Protector
(-)B2TZ2417STANMJ***	208-230	1	60	1/3 [249]	300-1100	5	1.8	2.3	15
(-)B2TZ3621STANMJ***	208-230	1	60	1/2 [373]	300-1100	5	2.4	3.0	15
(-)B2TZ4824STANMJ***	208-230	1	60	3/4 [559]	300-1100	5	3.8	4.8	15
(-)B2TZ6024STANMJ***	208-230	1	60	3/4 [559]	300-1100	5	5.0	6.3	15

Electrical Data—With Electric Heat

Model Size/Elec. Designation	Heater KW-Volts 208/240	Voltage	Phase	Hertz	HP [W]	RPM	Speeds	Heater Amps.	Motor Amps.	Minimum Circuit Ampacity	Maximum Circuit Protector
RB2TZ2417STANMJB05	3.7/4.9	208-230	1	60	1/3 [249]	300-1100	5	19.8/22.4	1.8	27/31	30/40
RB2TZ2417STANMJB07	5.3/7.0	208-230	1	60	1/3 [249]	300-1100	5	27.5/31.2	1.8	37/42	40/50
RB2TZ3621STANMJB05	3.7/4.9	208-230	1	60	1/2 [373]	300-1100	5	20.9/23.5	2.4	30/33	30/40
RB2TZ3621STANMJB07	5.3/7.0	208-230	1	60	1/2 [373]	300-1100	5	28.6/32.3	2.4	39/44	40/50
RB2TZ3621STANMJB10	7.5/10.0	208-230	1	60	1/2 [373]	300-1100	5	39.2/44.8	2.4	52/59	60/60
RB2TZ4824STANMJB05	3.7/4.9	208-230	1	60	3/4 [559]	300-1100	5	22.0/24.6	3.8	33/36	40/40
RB2TZ4824STANMJB07	5.3/7.0	208-230	1	60	3/4 [559]	300-1100	5	29.7/33.4	3.8	42/47	50/50
RB2TZ4824STANMJB10	7.5/10.0	208-230	1	60	3/4 [559]	300-1100	5	40.3/45.9	3.8	56/63	60/70
RB1TZ6024STANMJB10	7.5/10.0	208-230	1	60	3/4 [559]	300-1100	5	41.8/47.4	5	59/66	60/70

[] Designates Metric Conversions

Electrical Wiring

Power Wiring

- Field wiring must comply with the National Electrical Code (C.E.C. in Canada) and any applicable local ordinance.
- Supply wiring must be 75°C minimum copper conductors only.
- See electrical data for product Ampacity rating and Circuit Protector requirement.

Grounding

- This product must be sufficiently grounded in accordance with National Electrical Code (C.E.C. in Canada) and any applicable local ordinance.
- A grounding lug is provided.

ACCESSORIES

- **External Auxiliary Horizontal Drain Pan. RXBM-AA06**— Fits all models.

- **Replacement Filters**

<u>Model Cabinet Size</u>	<u>Filter Size In. [mm]</u>	<u>Part Number</u>
17	16.25 x 21 [413 x 533]	54-23217-02
21	19.75 x 21 [502 x 533]	54-23217-03
24	23.25 x 21 [591 x 533]	54-23217-04
25	23.25 x 21 [591 x 533]	54-23217-04

[] Designates Metric Conversions



The new degree of comfort.®

Endeavor™ Line Air Handlers



RF1PZ

Motor: PSC

Airflow Stages: Single-Stage

Expansion Device: Thermal Expansion Valve (TXV)

Efficiencies: 13.4 to 14.3 SEER2



Table of Contents

Features & Benefits	3
Model Number Identification	4
Dimensional Data	5
Unit Dimensions & Weights	6
Airflow Performance Data	7-8
Electrical Data	9-10
Limited Warranty	12

Features and Benefits

- **Quiet Operation¹:** Provided by a cabinet construction with 1.0 inch of foil faced insulation for quieter sound characteristics
- **Front or Bottom Return with Aluminum Indoor Coil Design:** Are constructed of aluminum fins bonded to internally grooved aluminum tubing and are more corrosion resistant
- **Rugged Steel Cabinet Construction:** Designed for added strength and versatility
- **Most Compact Unit Design Available:** All standard air handler models are only 36" [915mm] in height
- **Field-installed Auxiliary Heater Kits:** Provide exact heat for indoor comfort and include circuit breakers which meet UL and cUL requirements for service disconnect
- **Less than 2% Cabinet Air Leakage at 1-inch H₂O:** When tested in accordance with AHRAE Standard 193

[] Designates Metric Conversions

¹Based on manufacturer's air handler offering, and the product's airflow stages, motor type and cabinet insulation. Sound levels are also dependent on air handler location and installation.

Air Handlers

<u>R</u>	<u>F</u>	<u>1</u>	<u>P</u>	<u>Z</u>	<u>18</u>	<u>21</u>	<u>S</u>	<u>T</u>	<u>A</u>	<u>N</u>	<u>S</u>	<u>J</u>	<u>B</u>	<u>00</u>	<u>417</u>
Brand	Product Category	Stages Of Airflow	Motor Type	Refrigerant	Capacity	Width	Efficiency	Metering	Major Series	Controls	Coil Series	Voltage	Disconnect	Factory Heat	Option Code
R - Rheem	F - Front Return	1 - 1-Stage	P - PSC	Z - R-410A	18 - 18,000 [5.28 kW] 24 - 24,000 [7.03 kW] 30 - 30,000 [8.79 kW] 36 - 36,000 [10.55 kW]	21 - 21" 24 - 24.5"	S - Standard	T - TXV	A - 1st Design	N - Non-Communicating	S - Slab	J - 208-240/1/60	B - Breaker N - None	00 - No Heat 03 - 3 kW 05 - 5 kW 08 - 8 kW 10 - 10 kW	417 - Float Switch

Available Models
RF1PZ1821STANSJB03
RF1PZ1821STANSJB05
RF1PZ1821STANSJB08
RF1PZ1821STANSJN00
RF1PZ2421STANSJB03
RF1PZ2421STANSJB05
RF1PZ2421STANSJB08
RF1PZ2421STANSJB10
RF1PZ2421STANSJN00
RF1PZ3024STANSJB03
RF1PZ3024STANSJB05
RF1PZ3024STANSJB08
RF1PZ3024STANSJB10
RF1PZ3024STANSJN00
RF1PZ3624STANSJB03
RF1PZ3624STANSJB05
RF1PZ3624STANSJB08
RF1PZ3624STANSJB10
RF1PZ3624STANSJN00

Standard Equipment
The most compact unit design available, all standard heat air handler models only 36" [915 mm]
Rugged wall steel cabinet construction, designed for added strength and versatility
1.0" foil faced insulation for excellent thermal and sound performance
Four leg blower motor mount
Traditional open wire element design for heat applications
Indoor coil design provides low air side pressure drop, high performance and extremely compact size
Coils are constructed of aluminum fins and internally grooved aluminum tubing
Molded polymer corrosion resistant condensate drain pan is provided for all indoor coils
Connection point for high voltage wiring is inside the air handler cabinet. Low voltage connection is made on the outside of the air handler cabinet
Concentric knockouts are provided for power connection to cabinet. Installer may pull desired hole size up to 1-3/8 inches [35 mm] for 7/8 inch [22 mm] conduit

[] Designates Metric Conversions

Unit Dimensions

NOTE: 24" [610 mm] CLEARANCE REQUIRED IN FRONT OF UNIT FOR FILTER AND COIL MAINTENANCE

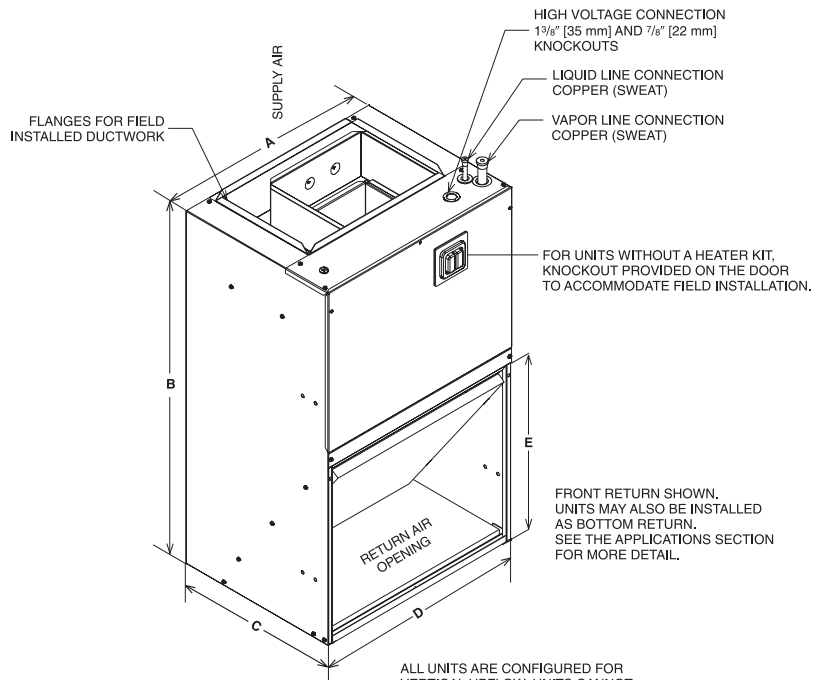

FRONT RETURN SHOWN. UNITS MAY ALSO BE INSTALLED AS BOTTOM RETURN. SEE THE APPLICATIONS SECTION FOR MORE DETAIL.

ALL UNITS ARE CONFIGURED FOR VERTICAL UPFLOW. UNITS CANNOT BE INSTALLED IN ANY OTHER CONFIGURATION.

Return Air Opening Dimensions

Model Cabinet Size	Return Air Opening Width (Inches)	Return Air Opening Depth/Length (Inches)
17	15 ⁷ / ₈	19 ³ / ₄
21	19 ³ / ₈	19 ³ / ₄
24	22 ⁷ / ₈	19 ³ / ₄

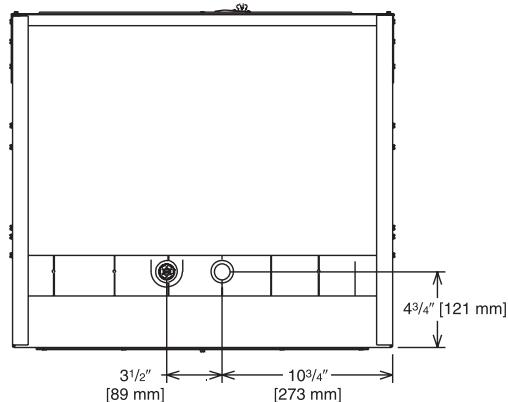
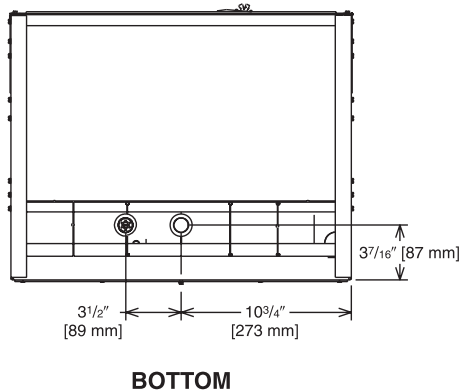
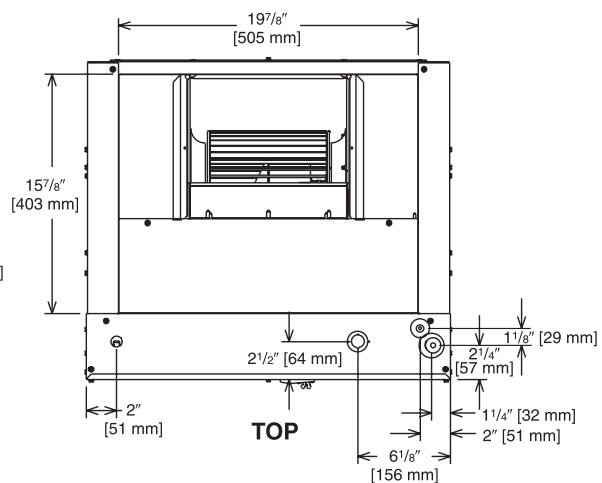
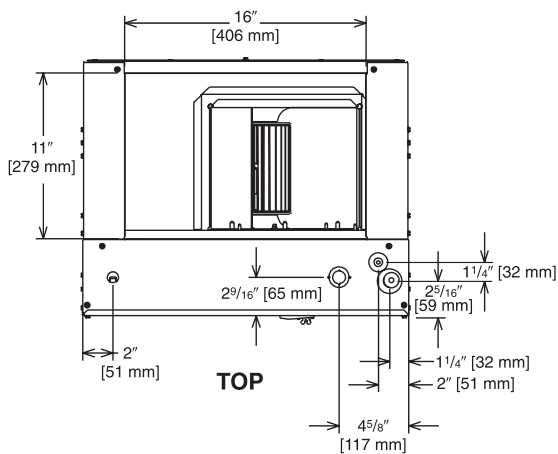

1 1/2 & 2 TON [5.28 & 7.03 kW] MODELS

2 1/2 & 3 TON [8.79 & 10.6 kW] MODELS

Unit Dimensions & Weights

Model	(A) Unit Width In. [mm]	(B) Unit Height In. [mm]	(C) Unit Depth In. [mm]	(D) Return Air Opening Width In. [mm]	(E) Return Air Opening Height In. [mm]	Filter Size in. x in. x in. [mm x mm x mm]	Air Flow CFM (Nom.) [L/s]		Unit Weight/ Shipping Weight (Lbs.) [kg]
							Low	High	
RF1PZ1821	21½ [546.1]	36 [914.4]	17 [431.8]	20 [508.0]	17 ⁷ / ₁₆ [442.9]	20 X 20 X 1 [508 X 508 X 25.4]	600 [283]	—	80 [36] / 90 [41]
RF1PZ2421	21½ [546.1]	36 [914.4]	17 [431.8]	20 [508.0]	17 ⁷ / ₁₆ [442.9]	20 X 20 X 1 [508 X 508 X 25.4]	800 [378]	—	80 [36] / 90 [41]
RF1PZ3024	24 [609.6]	36 [914.4]	21 [533.4]	23 [584.2]	21 ³ / ₈ [542.9]	20 X 25 X 1 [508 X 635 X 25.4]	1000 [472]	—	95 [43] x 105 [48]
RF1PZ3624	24 [609.6]	36 [914.4]	21 [533.4]	23 [584.2]	21 ³ / ₈ [542.9]	20 X 25 X 1 [508 X 635 X 25.4]	1200 [566]	—	95 [43] x 105 [48]

[] Designates Metric Conversions

Airflow Performance

Airflow performance data is based on cooling performance with a coil and no filter in place. Select performance table for appropriate unit size, voltage and number of electric heaters to be used. Make sure external static applied to unit allows operation within the minimum and maximum limits shown in

table below for both cooling and electric heat operation. For optimum blower performance, operate the unit in the .3 [8 mm] to .7 inches [18 mm] W.C. external static range. Units with coils should be applied with a minimum of .1 inch [3 mm] W.C. external static range.

Airflow Operating Limits

Model Cabinet Size	21		24	
Cooling BTUH x 1,000 Cooling Tons Nominal	-18 1.5	-24 2	-30 2.5	-36 3
Heat Pump or Air Conditioning Maximum Heat/Cool CFM [L/s] (37.5 CFM [18 L/s]/1,000 BTUH) (450 CFM [212 L/s]/Ton Nominal)	675 [319]	900 [425]	1125 [531]	1350 [637]
Heat Pump or Air Conditioning Nominal Heat/Cool CFM [L/s] (33.3 CFM [16 L/s]/1,000 BTUH) (400 CFM [189 L/s]/Ton Nominal)	600 [283]	800 [378]	1000 [472]	1200 [566]
Heat Pump or Air Conditioning Minimum Heat/Cool CFM [L/s] (30.0 CFM [14 L/s]/1,255 BTUH) (360 CFM [170 L/s]/Ton Nominal)	540 [255]	720 [340]	900 [425]	1080 [510]
Maximum kW Electric Heating & Minimum Electric Heat CFM [L/s]	8 450 [212]	10 690 [326]	10 808 [381]	10 976 [461]
Maximum Electric Heat Rise °F [°C]	54 [12]	44 [7]	44 [7]	44 [7]

[] Designates Metric Conversions

Airflow Performance Data – (-)F1PZ (PSC Motor)

Model/ Nominal Cooling Capacity	Manufacturer Recommended Airflow Range (Max./Min.) CFM	Blower Size/ Motor HP # of Speeds	Motor Speed From Factory	Motor Speed	PSC							
					CFM Dry Delivery/filter/heaters/RPM/Watts							
					External Static Pressure-Inches W.C.							
						0.10	0.20	0.30	0.40	0.50	0.60	0.70
(-)F1PZ18 1.5 Tons	873/438	10x6 1/5 Hp 2 speed dual voltage	High	High	CFM	873	828	785	751	707	—	—
					RPM	897	923	948	955	981	—	—
					Watts	288	286	283	280	274	—	—
				Low	CFM	572	543	508	477	438	—	—
					RPM	706	753	791	830	869	—	—
					Watts	184	181	187	178	172	—	—
(-)F1PZ24 2 Tons	1137/764	10x6 1/5 Hp 2 speed dual voltage	High	High	CFM	1137	1097	1034	985	933	868	810
					RPM	1101	1104	1114	1118	1124	1130	1136
					Watts	438	444	446	421	391	377	360
				Low	CFM	867	855	827	798	764	—	—
					RPM	864	902	948	978	1002	—	—
					Watts	324	317	290	285	283	—	—
(-)F1 PZ30 2.5 Tons	1148/802	10x8T 1/4 Hp 2 speed dual voltage	High	High	CFM	1363	1303	1240	1169	1096	1030	—
					RPM	1029	1047	1060	1082	1095	1104	—
					Watts	515	514	468	428	428	394	—
				Low	CFM	1196	1158	1105	1048	—	—	—
					RPM	958	984	1012	1037	—	—	—
					Watts	423	402	402	360	—	—	—
(-)F1 PZ36 3 Tons	1363/1048	10x8T 1/3 Hp 2 speed dual voltage	High	High	CFM	1523	1447	1375	1293	1209	1121	1037
					RPM	1081	1085	1090	1096	1102	1107	1113
					Watts	680	658	640	621	603	588	571
				Low	CFM	1333	1272	1201	1133	1060	979	888
					RPM	970	988	1003	1020	1064	1048	1064
					Watts	442	427	409	392	376	360	336

[] Designates Metric Conversions

Electrical Data – Blower Motor Only – No Electric Heat RF1PZ

Model/Nominal Cooling Tons	Voltage	Phase	Hertz	HP [W]	RPM	Speeds	Circuit Amps.	Minimum Circuit Ampacity	Maximum Circuit Protector
RF1PZ1821	208/230	1	60	1/5 [149]	1075	2	1.9	3	15
RF1PZ2421	208/230	1	60	1/4 [149]	1075	2	1.9	3	15
RF1PZ3024	208/230	1	60	1/3 [249]	1075	2	2.7	4	15
RF1PZ3624	208/230	1	60	1/2 [373]	1075	2	2.7	4	15

*Blower motors are all single phase motors.

RF1PZ Electrical Data – with Electric Heat

Installation of the U.L. Listed original equipment manufacturer provided heater kits listed in the table below is recommended for all auxiliary heating requirements.

Cooling Capacity Tons	Model No.	Heater kW	PH/Hz	No. Elements - kW Per	(208/240V) Type Supply Circuit	Circuit Amps.	Motor Ampacity	Minimum Circuit Ampacity	Maximum Circuit Protection
RF1PZ18	RXHJ-21B/T03J-1	2.25/3.0	1/60	1-3.0	Single	10.8/12.5	1.9	16/18	20/20
	RXHJ-21B/T05J	3.6/4.8	1/60	1-4.8	Single	17.3/20.0	1.9	0.9	25/30
	RXHJ-21B/T08J	5.4/7.2	1/60	2-3.6	Single	26.0/30.0	1.9	35/40	35/40
RF1PZ24	RXHJ-21B/T03J	2.25/3.0	1/60	1-3.0	Single	10.8/12.5	1.9	16/18	20/20
	RXHJ-21B/T05J	3.6/4.8	1/60	1-4.8	Single	17.3/20.0	1.9	0.9	25/30
	RXHJ-21B/T08J	5.4/7.2	1/60	2-3.6	Single	26.0/30.0	1.9	35/40	35/40
	RXHJ-21B/T10J	7.2/9.6	1/60	2-4.8	Single	34.6/40.0	1.9	0.9	50/60
RF1PZ30	RXHJ-24B/T03J	2.25/3.0	1/60	1-3.0	Single	10.8/12.5	2.7	17/19	20/20
	RXHJ-24B/T05J	3.6/4.8	1/60	1-4.8	Single	17.3/20.0	2.7	25/29	25/30
	RXHJ-24B/T08J	5.4/7.2	1/60	2-3.6	Single	26.0/30.0	2.7	36/41	40/45
	RXHJ-24B/T10J	7.2/9.6	1/60	2-4.8	Single	34.6/40.0	2.7	47/54	50/60
RF1PZ36	RXHJ-24B/T03J	2.25/3.0	1/60	1-3.0	Single	10.8/12.5	2.7	17/19	20/20
	RXHJ-24B/T05J	3.6/4.8	1/60	1-4.8	Single	17.3/20.0	2.7	25/29	25/30
	RXHJ-24B/T08J	5.4/7.2	1/60	2-3.6	Single	26.0/30.0	2.7	36/41	40/45
	RXHJ-24B/T10J	7.2/9.6	1/60	2-4.8	Single	34.6/40.0	2.7	47/54	50/60

- Electric heater BTUH - (heater watts + motor watts) x 3.414 (see airflow table for motor watts.)
- J voltage (230V) single phase air handler is designed to be used with single or three phase.
- Supply circuit protective devices may be fused or "HACR" type circuit breakers.
- If non-standard fuse size is specified, use next size larger standard fuse size. Without the heater, bring only two leads to terminal block, cap, insulate and fully secure the third lead.
- Largest motor load is included in single circuit or circuit 1 of multiple circuits.
- Do not use 480 volts electrical heaters on 230 volts air handler.
- No electrical heating elements are permitted to be used with A Voltage (115V) air handler.

Electrical Wiring: Power Wiring Grounding

- Field wiring must comply with the National Electrical Code
- This product must be sufficiently grounded in accordance with (C.E.C. in Canada) and any applicable local ordinance. National Electrical Code (C.E.C. in Canada) and any applicable
- Supply wiring must be 75°C minimum copper conductors only. Local ordinance.
- See electrical data for product Ampacity rating and Circuit.
- A grounding lug is provided. Protector requirement.

[] Designates Metric Conversions

16.0 Accessories-Kits-Parts

- **Drain Pan Over Flow Switch RXHK-A01** is used to detect condensate drain blockage and will shut down the outdoor unit in order to prevent structural damage to the surrounding structures of the air handler.

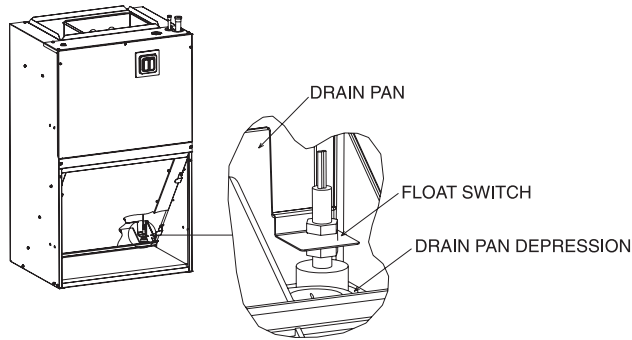

- **Bottom Return Conversion Kit RXHK-** is used to divert the return air from the factory standard front return to a bottom return.

Accessory Number	Indoor Unit
RXHK-B01	RF1PZ-FR18
	RF1PZ-FR24
RXHK-B02	RF1PZ-FR30
	RF1PZ-FR36

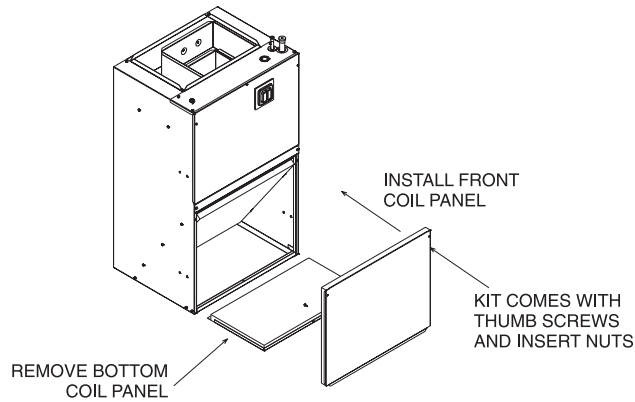

- **Louvered Cabinet Grill RXHK-** is used as decorative grill which covers the return air opening of the front return air handler.

Accessory Number	Indoor Unit
RXHK-C01	RF1PZ-FR18
	RF1PZ-FR24
RXHK-C02	RF1PZ-FR30
	RF1PZ-FR36

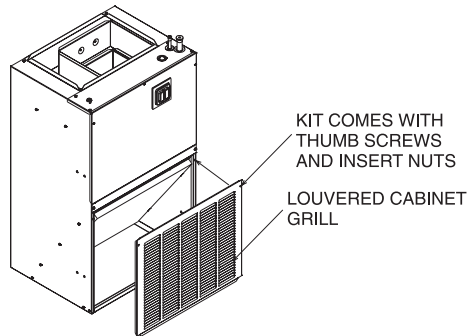

- **Decorative Wall Grill RXHK-D01** or **RXHK-D02** is used in applications where the air handler is installed in a closet or interior wall and allows adequate return air back to the unit. Please refer to RXHD-D01/RXHK-D02 installation instructions for complete dimensional information when selecting a decorative wall grill.

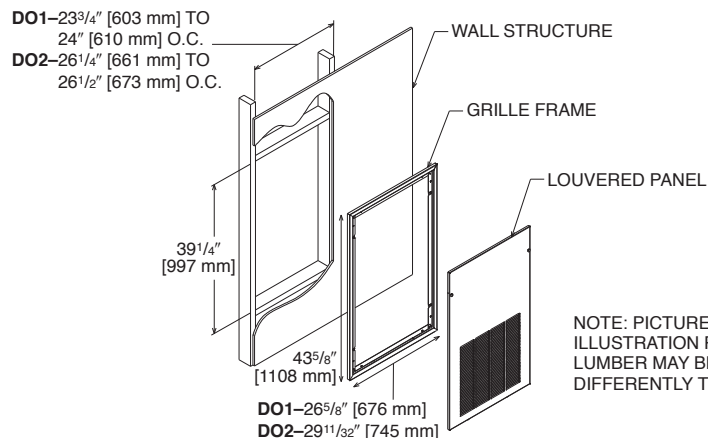

[] Designates Metric Conversions



The new degree of comfort.®

Endeavor™ Line Air Handlers



RF2TZ

Constant Torque Motor (ECM)

Two-Stage Airflow

Thermal Expansion Valve (TXV)

Efficiencies: 13.4 to 14.3 SEER2



Table of Contents

Features & Benefits	3
Model Number Identification	4
Dimensional Data	5
Unit Dimensions & Weights	6
Airflow Performance Data	7-8
Electrical Data	9-10
Limited Warranty	12

Features and Benefits

- **Quiet Operation¹:** Provided by a cabinet construction with 1.0 inch of foil faced insulation for quieter sound characteristics
- **Front or Bottom Return with Aluminum Indoor Coil Design:** Constructed of aluminum fins bonded to internally grooved aluminum tubing and are more corrosion resistant
- **Rugged Steel Cabinet Construction:** Designed for added strength and versatility
- **Most Compact Unit Design Available:** All Standard air handler models are only 36" [915 mm] in height

[] Designates Metric Conversions

¹Based on manufacturer's furnace offering, and the product's heating stages, motor type and cabinet insulation. Sound levels are also dependent on furnace location and installation.

Air Handlers

<u>R</u>	<u>F</u>	<u>2</u>	<u>T</u>	<u>Z</u>	<u>24</u>	<u>21</u>	<u>S</u>	<u>T</u>	<u>A</u>	<u>N</u>	<u>S</u>	<u>J</u>	<u>B</u>	<u>0</u>	<u>417</u>
Brand	Product Category	Stages Of Airflow	Motor Type	Refrigerant	Capacity	Width	Efficiency	Metering	Major Series	Controls	Coil Series	Voltage	Disconnect	Factory Heat	Option Code
R - Rheem	F - Front Return	2 - 2-Stage	T - Constant Torque	Z - R-410A	24 - 24,000 [7.03 kW] 36 - 36,000 [10.55 kW]	21 - 21" 24 - 24.5"	S - Standard	T - TXV	A - 1st Design	N - Non-Communicating	S - Slab	J - 208-240/1/60	B - Breaker N - None	0 - No Heat 3 - 3 kW 5 - 5 kW 8 - 8 kW 10 - 10 kW	417 - Float Switch

Available Models	Description
RF2TZ2421STANSJB03	Endeavor™ Line 2 ton Two-Stage Front Return 208-240V Air Handler
RF2TZ2421STANSJB03417	Endeavor™ Line 2 ton Two-Stage Front Return 208-240V Air Handler
RF2TZ2421STANSJB05	Endeavor™ Line 2 ton Two-Stage Front Return 208-240V Air Handler
RF2TZ2421STANSJB05417	Endeavor™ Line 2 ton Two-Stage Front Return 208-240V Air Handler
RF2TZ2421STANSJB08	Endeavor™ Line 2 ton Two-Stage Front Return 208-240V Air Handler
RF2TZ2421STANSJB08417	Endeavor™ Line 2 ton Two-Stage Front Return 208-240V Air Handler
RF2TZ2421STANSJB10	Endeavor™ Line 2 ton Two-Stage Front Return 208-240V Air Handler
RF2TZ2421STANSJB10417	Endeavor™ Line 2 ton Two-Stage Front Return 208-240V Air Handler
RF2TZ2421STANSJN00	Endeavor™ Line 2 ton Two-Stage Front Return 208-240V Air Handler
RF2TZ2421STANSJN00417	Endeavor™ Line 2 ton Two-Stage Front Return 208-240V Air Handler
RF2TZ3624STANSJB03	Endeavor™ Line 3 ton Two-Stage Front Return 208-240V Air Handler
RF2TZ3624STANSJB03417	Endeavor™ Line 3 ton Two-Stage Front Return 208-240V Air Handler
RF2TZ3624STANSJB05	Endeavor™ Line 3 ton Two-Stage Front Return 208-240V Air Handler
RF2TZ3624STANSJB05417	Endeavor™ Line 3 ton Two-Stage Front Return 208-240V Air Handler
RF2TZ3624STANSJB08	Endeavor™ Line 3 ton Two-Stage Front Return 208-240V Air Handler
RF2TZ3624STANSJB08417	Endeavor™ Line 3 ton Two-Stage Front Return 208-240V Air Handler
RF2TZ3624STANSJB10	Endeavor™ Line 3 ton Two-Stage Front Return 208-240V Air Handler
RF2TZ3624STANSJB10417	Endeavor™ Line 3 ton Two-Stage Front Return 208-240V Air Handler
RF2TZ3624STANSJN00	Endeavor™ Line 3 ton Two-Stage Front Return 208-240V Air Handler
RF2TZ3624STANSJN00417	Endeavor™ Line 3 ton Two-Stage Front Return 208-240V Air Handler

Standard Equipment
Exclusive Incoloy sheath type electric heating elements
Field convertible air supply
Durable framed cleanable air filter
Indoor coil design provides low air side pressure drop, high performance and compact size
PVC condensate elbow is standard on all coils
All indoor coils have aluminum tubing and aluminum fins
Molded polymer corrosion resistant condensate drain pan
Supply and return duct flanges
High and low voltage connection points inside cabinet
Concentric knockouts provided for power connection with hole size up to 2 inches [51 mm] for 1 1/2 inch [38mm] conduit
Internal checked TX valves for quiet refrigerant metering
Front refrigerant and drain connection
Fresh air knockouts

[] Designates Metric Conversions

Unit Dimensions

NOTE: 24" [610 mm] CLEARANCE REQUIRED IN FRONT OF UNIT FOR FILTER AND COIL MAINTENANCE

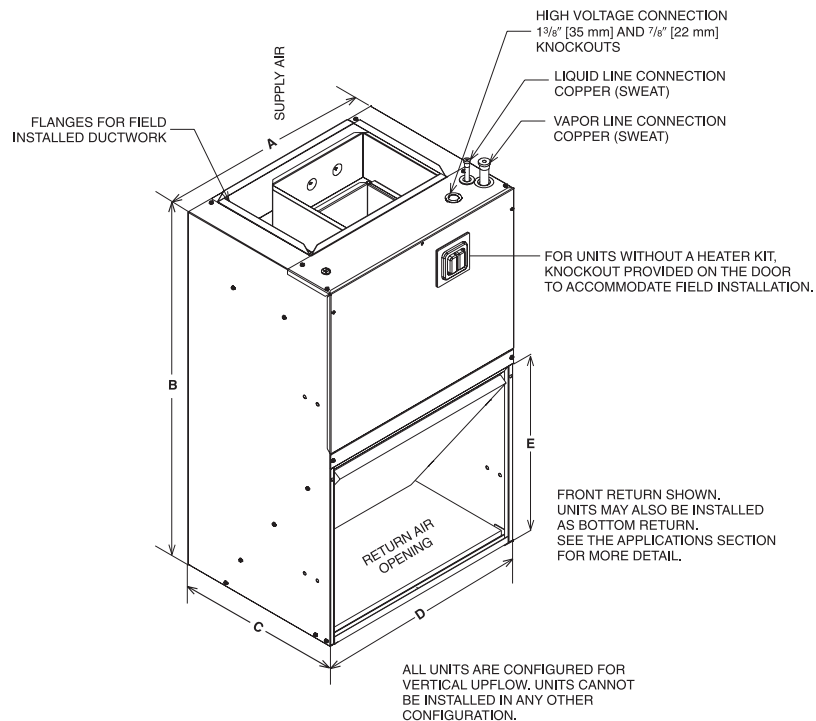

Return Air Opening Dimensions

Model Cabinet Size	Return Air Opening Width (Inches)	Return Air Opening Depth/Length (Inches)
17	15 ⁷ / ₈	19 ³ / ₄
21	19 ³ / ₈	19 ³ / ₄
24	22 ⁷ / ₈	19 ³ / ₄

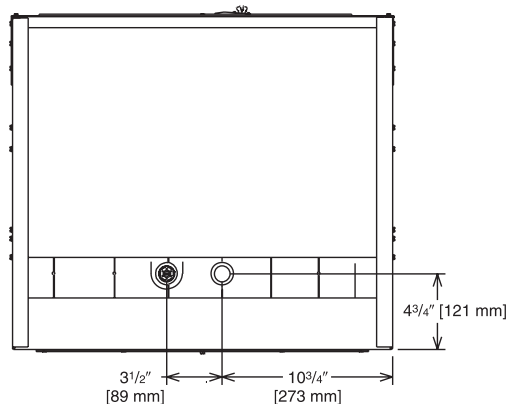
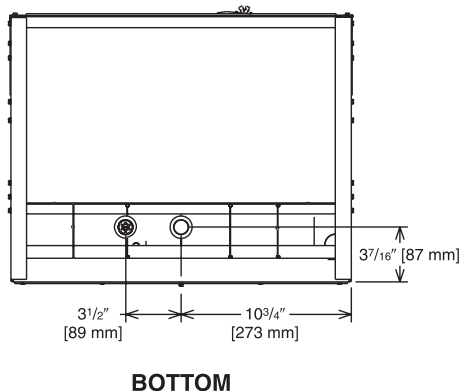
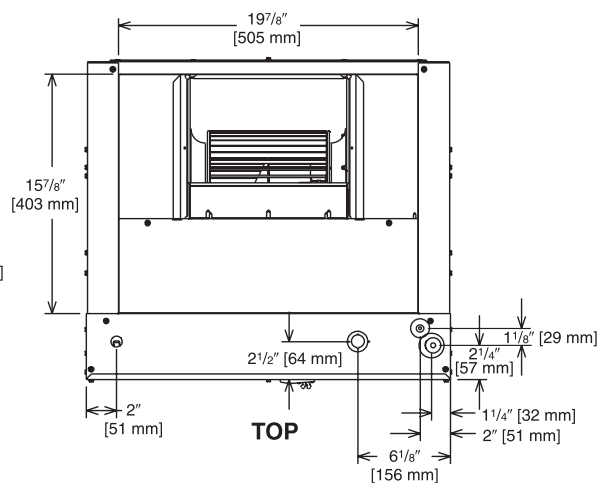
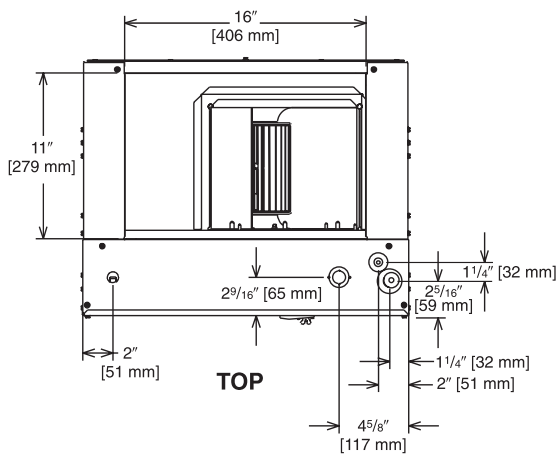

1 1/2 & 2 TON [5.28 & 7.03 kW] MODELS

2 1/2 & 3 TON [8.79 & 10.6 kW] MODELS

Unit Dimensions & Weights

Model	(A) Unit Width In. [mm]	(B) Unit Height In. [mm]	(C) Unit Depth In. [mm]	(D) Return Air Opening Width In. [mm]	(E) Return Air Opening Height In. [mm]	Filter Size in. x in. x in. [mm x mm x mm]	Air Flow CFM (Nom.) [L/s]		Unit Weight/Shipping Weight (Lbs.) [kg]
							Low	High	
RF2TZ2421	21 ^{1/2} [546.1]	36 [914.4]	17 [431.8]	20 [508.0]	17 ^{7/16} [442.9]	20 X 20 X 1 [508 X 508 X 25.4]	600 [283]	800 [378]	95 [43] x 105 [48]
RF2TZ3624	24 [609.6]	36 [914.4]	21 [533.4]	23 [584.2]	21 ^{3/8} [542.9]	20 X 25 X 1 [508 X 635 X 25.4]	1000 [472]	1200 [566]	95 [43] x 105 [48]

[] Designates Metric Conversions

Airflow Performance

Airflow performance data is based on cooling performance with a coil and no filter in place. Select performance table for appropriate unit size, voltage and number of electric heaters to be used. Make sure external static applied to unit allows operation within the minimum and maximum limits shown in

table below for both cooling and electric heat operation. For optimum blower performance, operate the unit in the .3 [8 mm] to .7 inches [18 mm] W.C. external static range. Units with coils should be applied with a minimum of .1 inch [3 mm] W.C. external static range.

Airflow Operating Limits

Model Cabinet Size	21	24
Cooling BTUH x 1,000	-24	-36
Cooling Tons Nominal	2	3
Heat Pump or Air Conditioning Maximum Heat/Cool CFM [L/s] (37.5 CFM [18 L/s]/1,000 BTUH) (450 CFM [212 L/s]/Ton Nominal)	900 [425]	1350 [637]
Heat Pump or Air Conditioning Nominal Heat/Cool CFM [L/s] (33.3 CFM [16 L/s]/1,000 BTUH) (400 CFM [189 L/s]/Ton Nominal)	800 [378]	1200 [566]
Heat Pump or Air Conditioning Minimum Heat/Cool CFM [L/s] (30.0 CFM [14 L/s]/1,255 BTUH) (360 CFM [170 L/s]/Ton Nominal)	720 [340]	1080 [510]
Maximum kW Electric Heating & Minimum Electric Heat CFM [L/s]	10 690 [326]	10 :976 [461]
Maximum Electric Heat Rise °F [°C]	44 [7]	44 [7]

[] Designates Metric Conversions

115V/208V/240V Airflow Performance Data—RF2TZ (Constant Torque (ECM) Motor)

Model/ Nominal Cooling Capacity	Air-Flow Range (Max/Min) CFM	Manufacturer Recommended Blower Size/ Motor HP # of Speeds	Motor Speed From Factory	Motor Speed	CFM Dry Delivery/filter/heaters/RPM/Watts							
					External Static Pressure-Inches W.C.							
						0.1	0.2	0.3	0.4	0.5	0.6	0.7
(-)F2TZ24 1.5 Tons	825/510	10x6 1/3 Hp 2 speed dual voltage	5	2	CFM	537	495	451	404	343	286	252
					RPM	608	656	702	752	826	879	935
					Watts	51.2	54.5	57.6	60.9	65.9	69.5	73.2
			5	3	CFM	735	702	666	634	600	565	528
					RPM	757	794	836	872	905	942	981
					Watts	99.1	103.2	107.7	112	115.6	119.6	124.1
(-)F2TZ24 2 Tons	973/733	10x6 1/3 Hp 2 speed dual voltage	5	4	CFM	654	616	581	542	503	463	399
					RPM	694	736	777	818	858	899	971
					Watts	76.4	80.1	83.7	87.6	91.3	95.1	101.6
			5	5	CFM	887	858	830	802	771	743	717
					RPM	876	914	945	976	1014	1044	1070
					Watts	156	161.8	166.8	171.5	177.5	182.3	186.2
(-)F2TZ36 2.5 Tons	1145/894	10x8 1/2 Hp 2 speed dual voltage	5	2	CFM	772	698	635	569	497	438	366
					RPM	595	639	698	771	821	866	933
					Watts	82.9	84.9	91.6	100	105.8	110.7	118.3
			5	3	CFM	1106	1053	1004	962	918	864	814
					RPM	776	816	838	862	901	955	1007
					Watts	183.3	191.4	195.7	200.5	208.4	219.3	230.2
(-)F2TZ36 3 Tons	1306/1040	10x8 1/2 Hp 2 speed dual voltage	5	4	CFM	808	750	698	633	568	504	448
					RPM	615	665	713	780	842	884	929
					Watts	91.4	97.7	103.9	112.4	120.2	125.5	131.2
			5	5	CFM	1241	1201	1148	1109	1065	1028	983
					RPM	847	880	905	916	955	991	1035
					Watts	246.3	254.9	260.9	263.8	273.1	282.5	293.3

NOTE: All (-)F2TZ air-handlers have 5 speed constant torque motors.

Speed tap 1 is for continuous fan. Speed tap 2 (low static) and speed tap 3 (high static) are for lower tonnage (1.5 or 2.5 tons). Speed tap 4 (low static) and speed tap 5 (high static) are for higher tonnage (2.0 or 3.0 tons).

(-)F2TZ air handlers are always shipped from factory at speed tap 5.

The low static speed tap 2 (lower tonnage) and 4 (higher tonnage) are for external static pressures below 0.5" WC. The high static speed tap 3 (lower tonnage) and 5 (higher tonnage) are used for external static exceeding 0.5" WC. Move the blue wire to the appropriate speed tap on the motor terminal block as required by the application needs.

The airflow for continuous fan (speed tap 1) is always set at 50% of the speed tap 4.

- The above airflow table lists the airflow information for air handlers with maximum heater allowed for each model.

Electrical Data – Blower Motor Only – No Electric Heat

Model/Nominal Cooling Tons	Voltage	Phase	Hertz	HP [W]	RPM	Speeds	Circuit Amps.	Minimum Circuit Ampacity	Maximum Circuit Protector
RF2TZ2421	208/230	1	60	1/3 [249]	300-1100	4	1.9	3	15
RF2TZ3624	208/230	1	60	1/2 [373]	300-1100	4	2.7	4	15

*Blower motors are all single phase motors.

Electrical Data – with Electric Heat

Installation of the U.L. Listed original equipment manufacturer provided heater kits listed in the table below is recommended for all auxiliary heating requirements.

Cooling Capacity Tons	Model No.	Heater kW	PH/Hz	No. Elements - kW Per	(208/240V) Type Supply Circuit	Circuit Amps.	Motor Ampacity	Minimum Circuit Ampacity	Maximum Circuit Protection
RF2TZ24	RXHJ-21B/T03J	2.25/3.0	1/60	1-3.0	Single	10.8/12.5	1.9	16/18	20/20
	RXHJ-21B/T05J	3.6/4.8	1/60	1-4.8	Single	17.3/20.0	1.9	0.9	25/30
	RXHJ-21B/T08J	5.4/7.2	1/60	2-3.6	Single	26.0/30.0	1.9	35/40	35/40
	RXHJ-21B/T10J	7.2/9.6	1/60	2-4.8	Single	34.6/40.0	1.9	0.9	50/60
RF2TZ36	RXHJ-24B/T03J	2.25/3.0	1/60	1-3.0	Single	10.8/12.5	2.7	17/19	20/20
	RXHJ-24B/T05J	3.6/4.8	1/60	1-4.8	Single	17.3/20.0	2.7	25/29	25/30
	RXHJ-24B/T08J	5.4/7.2	1/60	2-3.6	Single	26.0/30.0	2.7	36/41	40/45
	RXHJ-24B/T10J	7.2/9.6	1/60	2-4.8	Single	34.6/40.0	2.7	47/54	50/60

- Electric heater BTUH - (heater watts + motor watts) x 3.414 (see airflow table for motor watts.)
- J voltage (230V) single phase air handler is designed to be used with single or three phase.
- Supply circuit protective devices may be fused or "HACR" type circuit breakers.
- If non-standard fuse size is specified, use next size larger standard fuse size. Without the heater, bring only two leads to terminal block, cap, insulate and fully secure the third lead.
- Largest motor load is included in single circuit or circuit 1 of multiple circuits.
- Do not use 480 volts electrical heaters on 230 volts air handler.

Electrical Wiring: Power Wiring Grounding

- Field wiring must comply with the National Electrical Code
- This product must be sufficiently grounded in accordance with (C.E.C. in Canada) and any applicable local ordinance. National Electrical Code (C.E.C. in Canada) and any applicable
- Supply wiring must be 75°C minimum copper conductors only. Local ordinance.
- See electrical data for product Ampacity rating and Circuit.
- A grounding lug is provided. Protector requirement.

16.0 Accessories-Kits-Parts

- **Drain Pan Over Flow Switch RXHK-A01** is used to detect condensate drain blockage and will shut down the outdoor unit in order to prevent structural damage to the surrounding structures of the air handler.

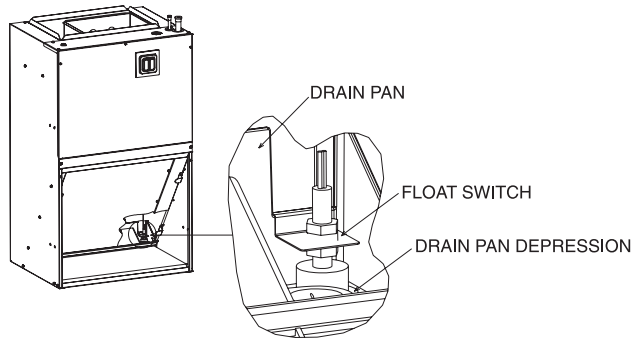

- **Bottom Return Conversion Kit RXHK-** is used to divert the return air from the factory standard front return to a bottom return.

Accessory Number	Indoor Unit
RXHK-B01	RF1P-FR18
	RF1P-FR24
	RF1T-FR24
RXHK-B02	RF1P-FR30
	RF1P-FR36
	RF1T-FR36

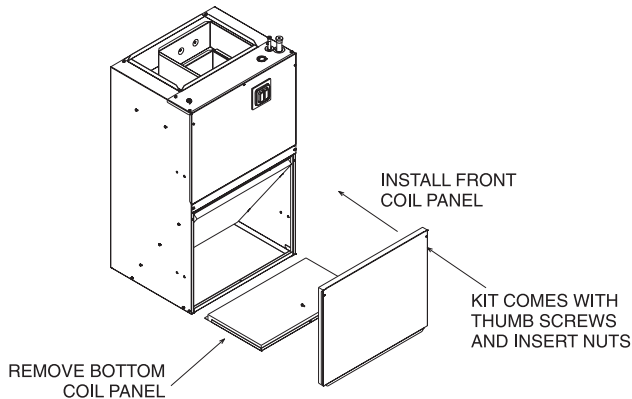

- **Louvered Cabinet Grill RXHK-** is used as decorative grill which covers the return air opening of the front return air handler.

Accessory Number	Indoor Unit
RXHK-C01	RF1P-FR18
	RF1P-FR24
	RF1T-FR24
RXHK-C02	RF1P-FR30
	RF1P-FR36
	RF1T-FR36

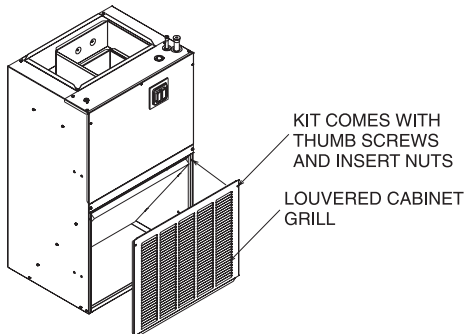

- **Decorative Wall Grill RXHK-D01 or RXHK-D02** is used in applications where the air handler is installed in a closet or interior wall and allows adequate return air back to the unit. Please refer to RXHD-D01/RXHK-D02 installation instructions for complete dimensional information when selecting a decorative wall grill.

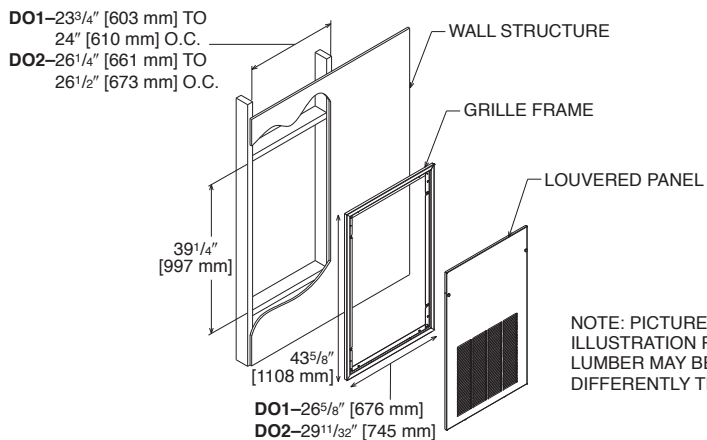

[] Designates Metric Conversions



The new degree of comfort.®

Endeavor™ Line Air Handlers



RH1PZ
PSC Motor
Single-Stage Airflow



Table of Contents

Features & Benefits	3
Model Number Identification	4
Dimensional Data	5
Unit Dimensions & Weights	6
Airflow Directional Data	7
Airflow Performance Data	8-10
Electrical Data	11-15
Limited Warranty	16

Features and Benefits

- Versatile 4-way convertible design for upflow, downflow, horizontal left and horizontal right applications
- Factory-installed indoor coil
- Sturdy cabinet construction with 1.0 inch [25.4 mm] of foil faced insulation for excellent sound and insulating characteristics
- Field-installed auxiliary electric heater kits provide exact heat for indoor comfort. Kits include circuit breakers which meet U.L. and cUL requirements for service disconnect
- 1-1/2 ton [5.3 kW] through 5 ton [17.6 kW] models are between 42-1/2 to 55-1/2 inches [1080 to 1410 mm] tall and 22 inches [559 mm] deep
- All models meet or exceed 330 to 400 CFM [156 to 189 L/s] per ton at .3 inches [.7 kPa] of external static pressure
- Enhanced airflow up to .7" external static pressure
- Evaporator is constructed of aluminum fins bonded to internally grooved aluminum tubing
- Cabinet air leakage less than 2% at 1 inch H₂O when tested in accordance with ASHRAE Standard 193

[] Designates Metric Conversions

Air Handlers

<u>R</u>	<u>H</u>	<u>1</u>	<u>P</u>	<u>Z</u>	<u>18</u>	<u>17</u>	<u>S</u>	<u>T</u>	<u>A</u>	<u>N</u>	<u>N</u>	<u>A</u>
Brand	Product Category	Stages Of Airflow	Motor Type	Refrigerant	Capacity	Width	Efficiency	Metering	Major Series	Controls	Coil Series	Voltage
R - Rheem	H - Multipoise Air Handler	1 - 1-Stage	P - PSC	Z - R-410A	18 - 18,000 [5.28 kW] 24 - 24,000 [7.03 kW] 30 - 30,000 [8.79 kW] 36 - 36,000 [10.55 kW] 42 - 42,000 [12.31 kW] 48 - 48,000 [14.07 kW] 60 - 60,000 [17.58 kW]	17 - 17.5" 21 - 21" 24 - 24.5"	S - Standard	T - TXV	A - 1st Design	N - Non-Communicating	N - N-Coil	A - 115/1/60 J - 208-240/1/60

Available Models

RH1PZ1817STANNA	RH1PZ3617STANNA	RH1PZ4221STANNJ
RH1PZ1817STANNJ	RH1PZ3617STANNJ	RH1PZ4821STANNA
RH1PZ2417STANNA	RH1PZ3621STANNA	RH1PZ4821STANNJ
RH1PZ2417STANNJ	RH1PZ3621STANNJ	RH1PZ4824STANNJ
RH1PZ3017STANNA	RH1PZ4221STANNA	RH1PZ6024STANNJ
RH1PZ3017STANNJ		

Standard Equipment

The most compact unit design available, all standard heat air handler models only 42-1/2 to 55-1/2 inches [1079 to 1409 mm] high
Attractive pre-painted cabinet exterior
Rugged wall steel cabinet construction, designed for added strength and versatility
1.0" foil faced insulation mechanically retained in blower compartment for excellent thermal and sound performance
Four leg blower motor mount
Blower housing with controls, motor and blower. Slide out design for service and maintenance convenience
Traditional open wire element design for heat applications
Field convertible for vertical downflow, horizontal left hand or right hand air supply
3 combustible floor base accessories fit all model sizes when required for downflow installations on combustible floors
Indoor coil design provides low air side pressure drop, high performance and extremely compact size
Expansion valve on indoor coil provides for operation with air conditioning
Coils are constructed of aluminum fins bonded to internally grooved aluminum tubing
Coils are tested at the factory with an extensive refrigerant leak check
Coils have copper sweat refrigerant connections
Coils utilize chatleff metering device connections
Molded polymer corrosion resistant condensate drain pan is provided on all indoor coils
Supply duct flanges provided as standard on air handler cabinet
Provisions for field electrical, connections available from either side or top of the air handler cabinet
Connection point for high voltage wiring is inside the air handler cabinet. Low voltage connection is made on the outside of the air handler cabinet
Concentric knockouts are provided for power connection to cabinet. Installer may pull desired hole size up to 2 inches [51 mm] for 1-1/2 inch [38 mm] conduit
Front refrigerant and drain connections

[] Designates Metric Conversions

Unit Dimensions

ELECTRICAL CONNECTIONS
MAY EXIT TOP OR EITHER SIDE
HIGH VOLTAGE CONNECTION 7/8" [22.2 mm],
1 3/32" [27.8 mm], 1 1/2" [50 mm] DIA. KNOCKOUTS.

LOW VOLTAGE CONNECTION
3/8" [15.9 mm] AND 7/8" [22.2 mm] KNOCKOUT

AUXILIARY DRAIN CONNECTION
3/4" [19.1 mm] FEMALE PIPE THREAD (NPT)
HORIZONTAL APPLICATION ONLY

PRIMARY DRAIN CONNECTION
3/4" [19.1 mm] FEMALE PIPE THREAD (NPT)

AUXILIARY DRAIN CONNECTION
3/4" [19.1 mm] FEMALE PIPE THREAD (NPT)
UPFLOW/DOWNFLOW APPLICATION ONLY

LIQUID LINE CONNECTION
COPPER (SWEAT)

VAPOR LINE CONNECTION
COPPER (SWEAT)

SUPPLY AIR ↑

NOTE: 24" CLEARANCE REQUIRED IN FRONT OF
UNIT FOR FILTER AND COIL MAINTENANCE.

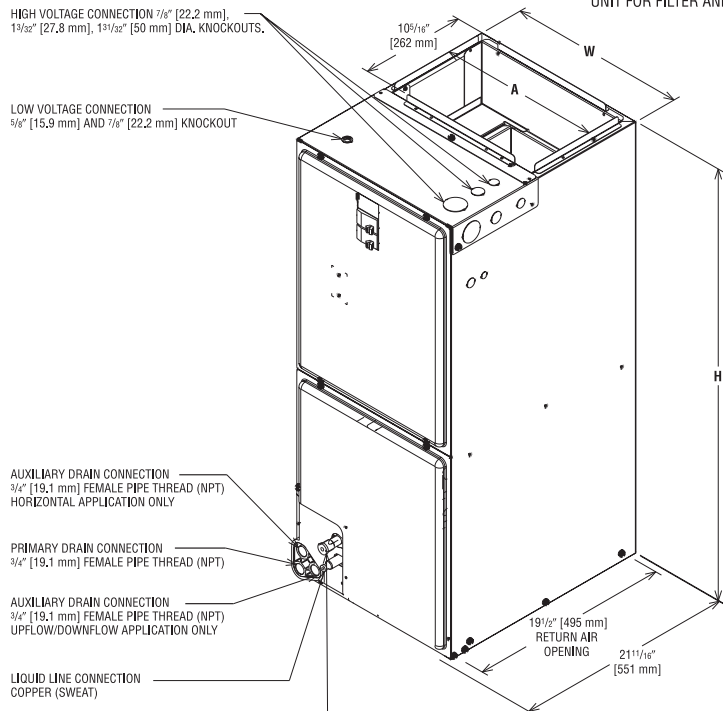

UPFLOW UNIT SHOWN:
UNIT MAY BE INSTALLED UPFLOW, DOWNFLOW,
HORIZONTAL RIGHT OR LEFT AIR SUPPLY.

Return Air Opening Dimensions

Model Cabinet Size	Return Air Opening Width (Inches)	Return Air Opening Depth/Length (Inches)
17	15 7/8	19 3/4
21	19 3/8	19 3/4
24	22 7/8	19 3/4

HORIZONTAL ADAPTER KIT

VAPOR LINE CONNECTION

AUXILIARY HORIZONTAL DRAIN CONNECTION

PRIMARY DRAIN CONNECTION

AUXILIARY UPFLOW/DOWNFLOW DRAIN CONNECTION

LIQUID LINE CONNECTION

VERTICAL DRAIN PAN

UPFLOW UNIT SHOWN:
UNIT MAY BE INSTALLED UPFLOW,
DOWNFLOW, HORIZONTAL RIGHT
OR LEFT AIR SUPPLY.

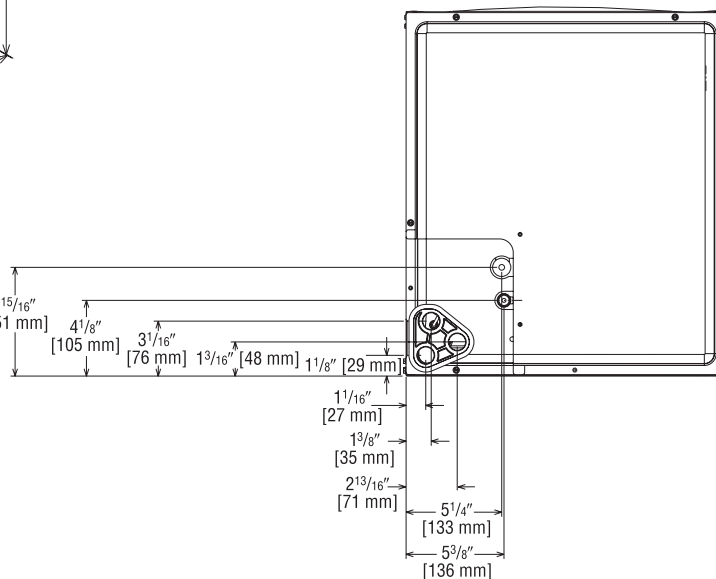

[] Designates Metric Conversions

() Designates Unit with Double Coil Cabinet

Unit Dimensions & Weights

Model Size RH1P	Refrigerant Connections Sweat (In.) [mm] ID		Unit Width "W" In. [mm]	Unit Height "H" In. [mm]	Supply Duct "A" In. [mm]	Air Flow CFM (Nom.) [L/s]		Unit Weight/Shipping Weight (Lbs.) [kg]
	Liquid	Vapor				Lo	Hi	Unit With Coil (Max. KW)
1817ST/2417ST	3/8 [9.53]	3/4 [19.05]	17 1/2 [445]	42 1/2 [1080]	16 [406]	600 [283]	800 [378]	81/95 [37/43]
3017ST/3617ST	3/8 [9.53]	3/4 [19.05]	17 1/2 [445]	42 1/2 [1080]	16 [406]	1000 [472]	1200 [566]	90/104 [41/47]
3621ST	3/8 [9.53]	7/8 [22.23]	21 [533]	42 1/2 [1080]	19 1/2 [495]	1200 [566]	—	109/124 [49/56]
4221ST/4821ST	3/8 [9.53]	7/8 [22.23]	21 [533]	50 1/2 [1282]	19 1/2 [495]	1400 [661]	1600 [755]	130/146 [59/66]
4824ST	3/8 [9.53]	7/8 [22.23]	24 1/2 [622]	50 1/2 [1282]	23 [584]	1600 [755]	—	143/161 [65/73]
6024ST	3/8 [9.53]	7/8 [22.23]	24 1/2 [622]	55 1/2 [1410]	23 [584]	—	1800 [850]	164/181 [75/82]

[] Designates Metric Conversions

Airflow Directional Data

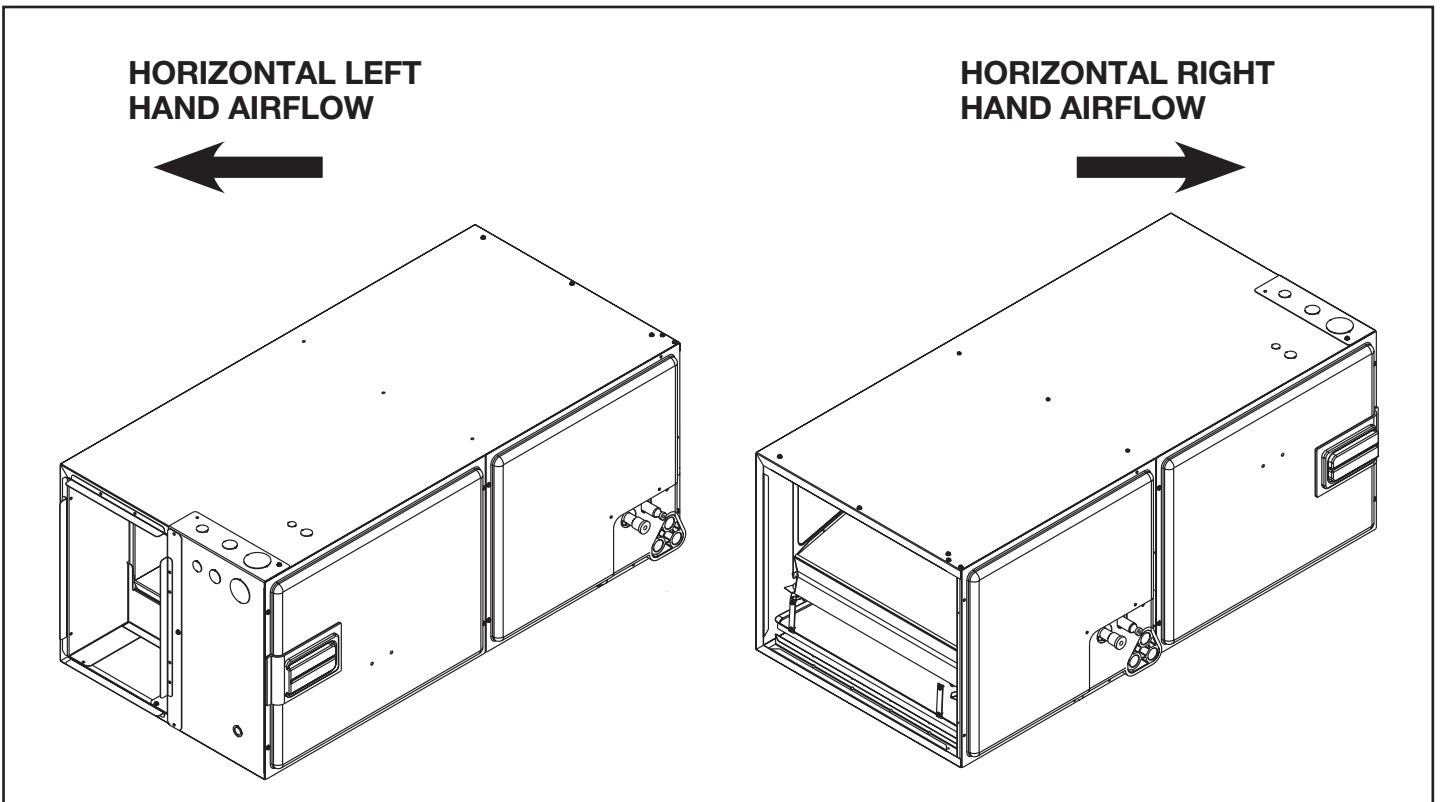
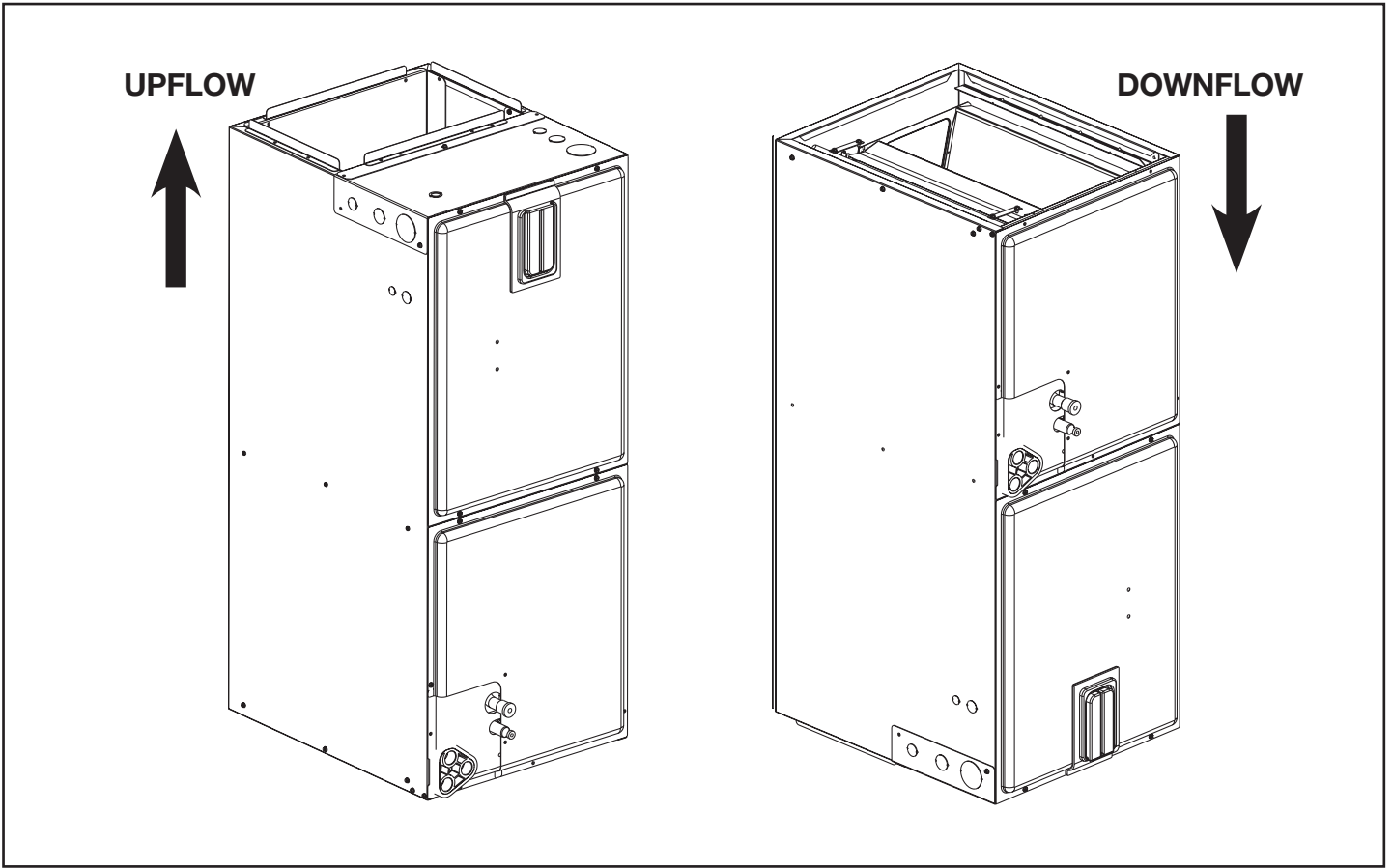

Airflow Performance

Airflow performance data is based on cooling performance with a coil and no filter in place. Select performance table for appropriate unit size, voltage and number of electric heaters to be used. Make sure external static applied to unit allows operation within the minimum and maximum limits shown in

table below for both cooling and electric heat operation. For optimum blower performance, operate the unit in the .3 [8 mm] to .7 inches [18 mm] W.C. external static range. Units with coils should be applied with a minimum of .1 inch [3 mm] W.C. external static range.

Airflow Operating Limits

Cabinet Width	17		17/21		21			24	
Cooling BTUH x 1,000 Cooling Tons Nominal	18 1.5	24 2	30 2.5	36 3	42 3.5	48 4	60 5	48 4	60 5
Heat Pump or Air Conditioning Maximum Heat/Cool CFM [L/s] (37.5 CFM [18 L/s]/1,000 BTUH) (450 CFM [212 L/s]/Ton Nominal)	675 [319]	900 [425]	1125 [531]	1350 [637]	1575 [743]	1800 [850]	1925 [907]	1800 [850]	1930* [911]
Heat Pump or Air Conditioning Nominal Heat/Cool CFM [L/s] (33.3 CFM [16 L/s]/1,000 BTUH) (400 CFM [189 L/s]/Ton Nominal)	600 [283]	800 [378]	1000 [472]	1200 [566]	1400 [661]	1600 [755]	1750 [826]	1550 [732]	1800* [850]
Heat Pump or Air Conditioning Minimum Heat/Cool CFM [L/s] (30.0 CFM [14 L/s]/1,000 BTUH) (360 CFM [170 L/s]/Ton Nominal)	540 [255]	720 [340]	900 [425]	1080 [510]	1260 [595]	1440 [680]	1575 [743]	1440 [680]	1620* [765]
Maximum kW Electric Heating & Minimum Electric Heat CFM [L/s]	13 487 [230]	13 617 [291]	18 814 [384]	18 1054 [497]	20 1171 [553]	25 1502 [709]	25 1502 [709]	25 1502 [709]	1666 [786]
Maximum Electric Heat Rise °F [°C]	80 [26.7]	63 [17.2]	66 [18.9]	51 [10.6]	49 [9.4]	50 [10]	50 [10]	50 [10]	54 [12.2]

*CFM [L/s] per ton requirements are reduced for 5 ton systems.

[] Designates Metric Conversions

115/208 Airflow Performance Data: (-)H1PZ (PSC Motor)

Air Handler Model (-)H1PZ	Motor Speed From Factory	Manufacturer Recommended Air Flow Range (Min./Max.) CFM	Blower Size/ Motor HP [W] # of Speeds	Motor Speed	PSC CFM[L/s] Air Delivery/RPM/Watts (Dry Coil — No Filter)							
					External Static Pressure-Inches W.C.							
						0.1 [.02]	0.2 [.05]	0.3 [.07]	0.4 [.10]	0.5 [.12]	0.6 [.15]	0.7 [.17]
1817ST No heater	High	517/711 CFM [244/336 Us]	10x6 1/5HP [149] 2 Speed	Low	CFM	668 [315]	637 [301]	595 [281]	560 [264]	517 [244]	—	—
					RPM	541	596	657	706	761	—	—
					Watts	180	171	166	161	155	—	—
				High	CFM	—	—	—	—	711 [336]	662 [312]	614 [290]
					RPM	—	—	—	—	812	853	890
					Watts	—	—	—	—	243	227	210
1817ST with 13kw heater	High	487/661 CFM [230/312 Us]	10x6 1/5HP [149] 2 Speed	Low	CFM	638 [301]	607 [286]	565 [267]	530 [250]	487 [230]	—	—
					RPM	571	656	687	736	791	—	—
					Watts	171	162	157	152	146	—	—
				High	CFM	—	—	—	—	661 [312]	612 [289]	564 [266]
					RPM	—	—	—	—	837	878	915
					Watts	—	—	—	—	232	216	199
24175T No heater	High	647/888 CFM [305/419 Us]	10x6 1/5HP [149] 2 Speed	Low	CFM	817 [386]	779 [368]	757 [357]	693 [327]	647 [305]	—	—
					RPM	616	667	715	770	808	—	—
					Watts	239	230	221	206	196	—	—
				High	CFM	—	—	—	—	888 [419]	828 [391]	774 [365]
					RPM	—	—	—	—	875	908	958
					Watts	—	—	—	—	331	313	301
2417ST with 13kw heater	High	617/838 CFM [291/395 Us]	10x6 1/5HP [149] 2 Speed	Low	CFM	787 [371]	749 [353]	727 [343]	663 [313]	617 [291]	—	—
					RPM	646	697	745	800	838	—	—
					Watts	230	221	212	197	187	—	—
				High	CFM	—	—	—	—	838 [395]	778 [367]	724 [342]
					RPM	—	—	—	—	900	933	983
					Watts	—	—	—	—	320	302	290
3017ST No heater	High	864/1004 CFM [408/474 Us]	10x8 1/4HP [186] 2 Speed	Low	CFM	1022 [482]	987 [466]	940 [444]	903 [426]	864 [408]	—	—
					RPM	700	754	794	833	870	—	—
					Watts	344	313	302	294	288	—	—
				High	CFM	—	—	—	—	1004 [474]	951 [449]	883 [417]
					RPM	—	—	—	—	924	953	975
					Watts	—	—	—	—	364	352	344
3017ST with 18kw heater	High	814/904 CFM [384/427 Us]	10x8 1/4HP [186] 2 Speed	Low	CFM	972 [459]	937 [442]	890 [420]	853 [403]	814 [384]	—	—
					RPM	750	804	844	883	920	—	—
					Watts	324	293	282	274	268	—	—
				High	CFM	—	—	—	—	904 [427]	851 [402]	783 [370]
					RPM	—	—	—	—	949	978	1000
					Watts	—	—	—	—	334	322	314
3617ST/ 3621ST No heater	High	1110/1248 CFM [524/589 Us]	10x8 1/3HP [249] 2 Speed	Low	CFM	1201 [567]	1170 [552]	1141 [538]	1104 [521]	1062 [501]	—	—
					RPM	833	872	909	951	965	—	—
					Watts	462	427	406	396	385	—	—
				High	CFM	—	—	—	—	1194 [563]	1134 [535]	1078 [509]
					RPM	—	—	—	—	1024	1042	1060
					Watts	—	—	—	—	475	454	417

[] Designates Metric Conversions

115/208 Airflow Performance Data: (-)H1PZ (PSC Motor) (Con't.)

Air Handler Model (-)H1PZ	Motor Speed From Factory	Manufacturer Recommended Air Flow Range (Min./Max.) CFM	Blower Size/ Motor HP [W] # of Speeds	Motor Speed	PSC CFM[L/s] Air Delivery/RPM/Watts (Dry Coil — No Filter)							
					External Static Pressure-Inches W.C.							
						0.1 [.02]	0.2 [.05]	0.3 [.07]	0.4 [.10]	0.5 [.12]	0.6 [.15]	0.7 [.17]
3617ST/ 3621ST with 18kw heater	High	1060/1148 CFM [500/542 Us]	10x8 1/3HP [249] 2 Speed	Low	CFM	1151 [543]	1120 [529]	1091 [515]	1054 [497]	1012 [478]	—	—
					RPM	883	922	959	1001	1015	—	—
					Watts	442	407	386	376	365	—	—
				High	CFM	—	—	—	—	1094 [516]	1034 [488]	978 [462]
					RPM	—	—	—	—	1049	1067	1085
					Watts	—	—	—	—	445	424	386
4221ST No heater	High	1241/1537 CFM [586/725 Us]	10x10 1/2HP [373] 2 Speed	Low	CFM	1493 [705]	1449 [684]	1363 [643]	1287 [607]	1211 [571]	—	—
					RPM	822	858	885	931	958	—	—
					Watts	540	519	506	484	459	—	—
				High	CFM	—	—	—	—	1514 [714]	1411 [666]	1315 [621]
					RPM	—	—	—	—	1061	1069	1078
					Watts	—	—	—	—	710	702	677
4221ST with 20kw heater	High	1225/1500 CFM [553/678 Us]	10x10 1/2HP [373] 2 Speed	Low	CFM	1423 [672]	1379 [651]	1293 [610]	1217 [574]	1141 [538]	—	—
					RPM	870	882	925	957	992	—	—
					Watts	514	508	490	461	431	—	—
				High	CFM	—	—	—	—	1414 [667]	1311 [619]	1215 [573]
					RPM	—	—	—	—	1067	1080	1094
					Watts	—	—	—	—	700	678	665
4821ST/ 4824ST No heater	High	1395/1824 CFM [658/861 Us]	10x10 3/4HP [559] 2 Speed	Low	CFM	1488 [702]	1477 [670]	1466 [692]	1430 [675]	1395 [658]	—	—
					RPM	812	861	912	943	973	—	—
					Watts	554	545	526	508	491	—	—
				High	CFM	—	—	—	—	1824 [861]	1767 [834]	1653 [780]
					RPM	—	—	—	—	1102	1112	1121
					Watts	—	—	—	—	871	830	770
4821ST/ 4824ST with 25kw heater	High	1225/1500 CFM [625/814 Us]	10x10 3/4HP [559] 2 Speed	Low	CFM	1418 [669]	1349 [637]	1396 [659]	1360 [642]	1325 [625]	—	—
					RPM	862	899	935	965	995	—	—
					Watts	534	525	506	588	471	—	—
				High	CFM	—	—	—	—	1724 [814]	1667 [787]	1553 [733]
					RPM	—	—	—	—	1116	1119	1130
					Watts	—	—	—	—	810	780	730
6024ST No heater	High	1710/1967 CFM [807/928 Us]	11x11 3/4HP [559] 2 Speed	Low	CFM	1866 [881]	1833 [865]	1806 [852]	1772 [836]	1710 [807]	—	—
					RPM	764	803	824	856	886	—	—
					Watts	514	756	733	715	701	—	—
				High	CFM	—	—	—	—	1967 [928]	1916 [904]	1863 [879]
					RPM	—	—	—	—	948	959	991
					Watts	—	—	—	—	850	827	816
6024ST with 30kw heater	High	1640/1796 CFM [773/847 Us]	11x11 3/4HP [559] 2 Speed	Low	CFM	1796 [848]	1763 [832]	1736 [819]	1702 [803]	1640 [774]	—	—
					RPM	828	860	878	890	1001	—	—
					Watts	735	718	705	695	678	—	—
				High	CFM	—	—	—	—	1867 [881]	1816 [857]	1763 [832]
					RPM	—	—	—	—	989	1005	1020
					Watts	—	—	—	—	818	795	780

[] Designates Metric Conversions

Electrical Data – Blower Motor Only – No Electric Heat

Air Handler Model (-)H1PZ	Voltage	Phase*	Hertz	HP	RPM	Speeds	Circuit Amps.	Minimum Circuit Ampacity	Maximum Circuit Protector
1817S	115	1	60	1/5	1075	2	2.3	3.0	15
2417S				1/5	1075	2	3.8	5.0	15
3017S				1/4	1075	2	4.7	6.0	15
3617S				1/3	1075	2	6.1	8.0	15
4221S				1/2	1075	2	7.9	10.0	15
4821S				3/4	1075	2	8.4	11.0	15
1817S	208/240	1	60	1/5	1075	2	1.7	3.0	15
2417S				1/5	1075	2	1.7	3.0	15
3017S				1/4	1075	2	2.5	4.0	15
3617S/3621S				1/3	1075	2	2.5	4.0	15
4221S				1/2	1075	2	5.2	7.0	15
4821ST/4824ST				3/4	1075	2	5.2	7.0	15
6024ST	3/4	1075	2	5.2	7.0	15			

Electrical Data – With Electric Heat

Air Handler Model (-)H1PZ	Heater Model No.	Heater kW (208/240V)	PH/HZ	No. Elements kW Per	Type Supply Circuit Single Circuit Multiple Circuit	Heater Amps.	Motor Amps.	Minimum Circuit Ampacity	Maximum Overcurrent Protection
1817S 2417S (208/240V)	RXBH-172403J-1	2.25/3.0	1/60	1-3.0	SINGLE	10.8/12.5	1.7	16/18	20/20
	RXBH-172403J-1	2.25/3.0	1/60	1-3.0	SINGLE	10.8/12.5	1.7	16/18	20/20
	RXBH-172405J-1	3.6/4.8	1/60	1-4.8	SINGLE	17.3/20.0	1.7	24/28	25/30
	RXBH-172407J-1	5.4/7.2	1/60	2-3.6	SINGLE	26.0/30.0	1.7	35/40	35/40
	RXBH-172410J-1	7.2/9.6	1/60	2-4.8	SINGLE	34.6/40.0	1.7	46/53	50/60
	RXBH-1724A13J-1	9.4/12.5	1/60	3-4.17	SINGLE	45.1/52.1	1.7	59/68	60/70
	RXBH-1724A13J-1	3.1/4.2	1/60	1-4.17	MULTIPLE CKT 1	15.0/17.4	1.7	21/24	25/25
		6.3/8.3	1/60	2-4.17	MULTIPLE CKT 2	30.1/34.7	0	38/44	40/45
	RXBH-1724A07C-1	5.4/7.2	3/60	3-2.4	SINGLE	15.0/17.3	1.7	21/24	25/25
	RXBH-1724A10C-1	7.2/9.6	3/60	3-3.2	SINGLE	20.0/23.1	1.7	28/31	30/35
RXBH-1724A13C-1	9.4/12.5	3/60	3-4.17	SINGLE	26.1/30.1	1.7	35/40	35/40	
3017S/3617S (208/240V)	RXBH-172403J-1	2.25/3.0	1/60	1-3.0	SINGLE	10.8/12.5	2.5	17/19	20/20
3017S 3617S 3621S (208/240V)	RXBH-172403J-1	2.25/3.0	1/60	1-3.0	SINGLE	10.8/12.5	2.5	17/19	20/20
	RXBH-172405J-1	3.6/4.8	1/60	1-4.8	SINGLE	17.3/20.0	2.5	25/29	25/30
	RXBH-172407J-1	5.4/7.2	1/60	2-3.6	SINGLE	26.0/30.0	2.5	36/41	40/45
	RXBH-172410J-1	7.2/9.6	1/60	2-4.8	SINGLE	34.6/40.0	2.5	47/54	50/60
	RXBH-1724A13J-1	9.4/12.5	1/60	3-4.17	SINGLE	45.1/52.1	2.5	60/69	60/70
	RXBH-1724A13J-1	3.1/4.2	1/60	1-4.17	MULTIPLE CKT 1	15.0/17.4	2.5	22/25	25/25
		6.3/8.3	1/60	2-4.17	MULTIPLE CKT 2	30.1/34.7	0	38/44	40/45
	RXBH-1724A15J-1	10.8/14.4	1/60	3-4.8	SINGLE	51.9/60.0	2.5	68/79	70/80
	RXBH-1724A15J-1	3.6/4.8	1/60	1-4.8	MULTIPLE CKT 1	17.3/20.0	2.5	25/29	25/30
		7.2/9.6	1/60	2-4.8	MULTIPLE CKT 2	34.6/40.0	0	44/50	45/50
	RXBH-1724A18J-1	12.8/17.0	1/60	3-5.68	SINGLE	61.6/70.8	2.5	81/92	90/100
	RXBH-1724A18J-1	4.3/5.7	1/60	1-5.68	MULTIPLE CKT 1	20.5/23.6	2.5	29/33	30/35
		8.5/11.3	1/60	2-5.68	MULTIPLE CKT 2	41.1/47.2	0	52/59	60/60
	RXBH-1724A07C-1	5.4/7.2	3/60	3-2.4	SINGLE	15.0/17.3	2.5	22/25	25/25
	RXBH-1724A10C-1	7.2/9.6	3/60	3-3.2	SINGLE	20.0/23.1	2.5	29/32	30/35
	RXBH-1724A13C-1	9.4/12.5	3/60	3-4.17	SINGLE	26.1/30.1	2.5	36/41	40/45
	RXBH-1724A15C-1	10.8/14.4	3/60	3-4.8	SINGLE	30.0/34.6	2.5	41/47	45/50
	RXBH-1724A18C-1	12.8/17.0	3/60	3-5.68	SINGLE	35.5/41.0	2.5	48/55	50/60

? Heater Kit Connection Type A = Breaker B = Terminal Block C = Pullout Disconnect

Electrical Data – With Electric Heat (Con't.)

Air Handler Model (-)H1PZ	Heater Model No.	Heater kW (208/240V)	PH/HZ	No. Elements kW Per	Type Supply Circuit Single Circuit Multiple Circuit	Heater Amps.	Motor Amps.	Minimum Circuit Ampacity	Maximum Overcurrent Protection
4221S 4821S 4824S (208/240V)	RXBH-1724?05J-1	3.6/4.8	1/60	1-4.8	SINGLE	17.3/20.0	5.2	29/32	30/35
	RXBH-1724?07J-1	5.4/7.2	1/60	2-3.6	SINGLE	26.0/30.0	5.2	39/44	40/45
	RXBH-1724?10J-1	7.2/9.6	1/60	2-4.8	SINGLE	34.6/40.0	5.2	50/57	50/60
	RXBH-1724A15J-1	10.8/14.4	1/60	3-4.8	SINGLE	51.9/60.0	5.2	72/82	80/90
	RXBH-1724A15J-1	3.6/4.8	1/61	1-4.8	MULTIPLE CKT 1	17.3/20.0	5.2	29/32	30/35
		7.2/9.6	1/60	2-4.8	MULTIPLE CKT 2	34.6/40.0	0.0	44/50	45/50
	RXBH-1724A18J-1	12/8/17	1/60	3-5.68	SINGLE	61.6/70.8	5.2	84/95	90/100
	RXBH-1724A18J-1	4.3/5.7	1/60	1-5.68	MULTIPLE CKT 1	20.5/23.6	5.2	33/36	35/40
		8.5/11.3	1/60	1-5.68	MULTIPLECKT2	41.1/47.2	0.0	52/59	60/60
	RXBH-24A20J-1	14.4/19.2	1/60	4-4.8	SINGLE	69.2/80	5.2	93/107	100/110
	RXBH-24A20J-1	7.2/9.5	1/60	2-4.8	MULTIPLE CKT 1	34.6/40.0	5.2	50/57	50/60
		7.2/9.6	1/60	2-4.8	MULTIPLE CKT 2	34.6/40.0	0.0	44/50	45/50
	RXBH-24A25J-1	18.0/24.0	1/60	6-4.0	SINGLE	86.4/99.9	5.2	115/132	125/150
	RXBH-24A25J-1 (4-ton only)	6.0/8.0	1/60	2-4.0	MULTIPLE CKT 1	28.8/33.3	5.2	43/49	45/50
		6.0/8.0	1/60	2-4.0	MULTIPLE CKT 2	28.8/33.3	0.0	36/42	40/45
		6.0/8.0	1/60	2-4.0	MULTIPLE CKT 3	28.8/33.3	0.0	36/42	40/45
	RXBH-1724A070-1	5.4/7.2	3/60	3-2.4	SINGLE	15.0/17.3	5.2	26/29	30/30
	RXBH-1724A10C-1	7.2/9.6	3/60	3-3.2	SINGLE	20.0/23.1	5.2	32/36	35/40
	RXBH-1724A15C-1	10.8/14.4	3/60	3-4.8	SINGLE	30.0/34.6	5.2	44/50	45/50
	RXBH-1724A180-1	12.8/17.0	3/60	3-5.68	SINGLE	35.6/41.0	5.2	51/58	60/60
	RXBH-24A20C*-1	14.4/19.2	3/60	6-3.2	SINGLE	40.0/46.2	5.2	57/65	60/70
	RXBH-24A20C-1	7.2/9.6	3/60	3-3.2	MULTIPLE CKT 1	20.0/23.1	5.2	32/36	35/40
		7.2/9.6	3/60	3-3.2	MULTIPLE CKT 2	20.0/23.1	0.0	25/29	25/30
	RXBH-24A25C*-1	18.0/24.0	3/60	6-4.0	SINGLE	50.0/57.8	5.2	69/79	70/80
	RXBH-24A25C-1 (4-ton only)	9.0/12.0	3/60	3-4.0	MULTIPLE CKT 1	25.0/28.9	5.2	38/43	40/45
		9.0/12.0	3/60	3-4.0	MULTIPLE CKT 2	25.0/28.9	0.0	32/37	35/40

? Heater Kit Connection Type A = Breaker B = Terminal Block C = Pullout Disconnect

Electrical Data – With Electric Heat (Con't.)

Air Handler Model (-)H1PZ	Heater Model No.	Heater kW (208/240V)	PH/HZ	No. Elements kW Per	Type Supply Circuit Single Circuit Multiple Circuit	Heater Amps.	Motor Amps.	Minimum Circuit Ampacity	Maximum Overcurrent Protection
6024S (208/240V)	RXBH-1724?05J-1	3.6/4.8	1/60	1-4.8	SINGLE	17.3/20.0	5.2	29/32	30/35
	RXBH-1724?07J-1	5.4/7.2	1/60	2-3.6	SINGLE	26.0/30.0	5.2	39/44	40/45
	RXBH-1724?10J-1	7.2/9.6	1/60	2-4.8	SINGLE	34.6/40.0	5.2	50/57	50/60
	RXBH-1724A15J-1	10.8/14.4	1/60	3-4.8	SINGLE	51.9/60.0	5.2	72/82	80/90
	RXBH-1724A15J-1	3.6/4.8	1/60	1-4.8	MULTIPLE CKT1	17.3/20.0	5.2	29/32	30/35
		7.2/9.6	1/60	2-4.8	MULTIPLE CKT 2	34.6/40.0	0	44/50	45/50
	RXBH-1724A18J-1	12.8/17.0	1/60	3/5/68	SINGLE	61.6/70.8	5.2	84/95	90/100
	RXBH-1724A18J -1	4.3/5.7	1/60	1/5/68	MULTIPLE CKT 1	20.5/23.6	5.2	33/36	35/40
		8.5/11.3	1/60	2/5/68	MULTIPLECKT2	41.1/47.2	0	52/59	60/60
	RXBH-24A20J-1	14.4/19.2	1/60	4-4.8	SINGLE	69.2/80	5.2	93/107	100/110
	RXBH-24A20J-1	7.2/9.6	1/60	2-4.8	MULTIPLE CKT 1	34.6/40.0	5.2	50/57	50/60
		7.2/9.6	1/60	2-4.8	MULTIPLE CKT 2	34.6/40.0	0	44/50	45/50
	RXBH-24A25J-1	18.0/24.0	1/60	6-4.0	SINGLE	86.4/99.9	5.2	115/132	125/150
	RXBH-24A25J-1	6.0/8.0	1/60	2-4.0	MULTIPLE CKT 1	28.8/33.3	5.2	43/49	45/50
		6.0/8.0	1/60	2-4.0	MULTIPLE CKT 2	28.8/33.3	0	36/42	40/45
		6.0/8.0	1/60	2-4.0	MULTIPLE CKT 3	28.8/33.3	0	36/42	40/45
	RXBH-24A30J-1	21.6/28.8	1/60	6-4.8	SINGLE	103.8/120	5.2	137/157	150/175
	RXBH-24A30J-1	7.2/9.6	1/60	2-4.8	MULTIPLE CKT 1	34.6/40.0	5.2	50/57	50/60
		7.2/9.6	1/60	2-4.8	MULTIPLE CKT 2	34.6/40.0	0	44/50	45/50
		7.2/9.6	1/60	2-4.8	MULTIPLE CKT 3	34.6/40.0	0	44/50	45/50

? Heater Kit Connection Type A = Breaker B = Terminal Block C = Pullout Disconnect

Electrical Wiring

Power Wiring

- Field wiring must comply with the National Electrical Code (C.E.C. in Canada) and any applicable local ordinance.
- Supply wiring must be 75°C minimum copper conductors only.
- See electrical data for product Ampacity rating and Circuit Protector requirement.

Grounding

- This product must be sufficiently grounded in accordance with National Electrical Code (C.E.C. in Canada) and any applicable local ordinance.
- A grounding lug is provided.

Accessories

• Combustible Floor Base RXHB-

Model Cabinet Size	Combustible Floor Base Model Number
17	RXHB-17
21	RXHB-21
24	RXHB-24

- **Jumper Bar Kit 3 Ckt. to 1 Ckt. RXBJ-A31** is used to convert single phase multiple three circuit units to a single supply circuit. Kit includes cover and screw for line side terminals.
- **Jumper Bar Kit 2 Ckt. to 1 Ckt. RXBJ-A21** is used to convert single phase multiple two circuit units to a single supply circuit. Kit includes cover and screw for line side terminals.
- **Note:** No jumper bar kit is available to convert three phase multiple two circuit units to a single supply circuit.
- **Auxiliary Horizontal Overflow Pan Accessory RXBM-**

Nominal Cooling Capacity-Tons	Auxiliary Horizontal Overflow Pan Accessory Model Number
1 ¹ / ₂ - 3	RXBM-AC48
3 ¹ / ₂ - 5	RXBM-AC61

• Auxiliary Electric Heater Kits RXBH-

Heater Kits include circuit breakers which meet UL and cUL requirements for service disconnect. See the Electric Heat Electrical Data in this specification sheet for specific Heater Kit Model numbers.

• Horizontal Adapter Kit RXHH-

This horizontal adapter kit is used to convert Upflow/Downflow only models to horizontal flow. See the following table to order proper horizontal adapter kit.

Coil Model	Horizontal Adapter Kit Model Number (Single Qty.)	Horizontal Adapter Kit Model Number (10-Pack Qty.)
2414	RXHH-A01	RXHH-A01 x 10
2417	RXHH-A02	RXHH-A02 x 10
3617/3621	RXHH-A03	RXHH-A03 x 10
3821/4821/4824	RXHH-A04	RXHH-A04 x 10
3621HT/4821MT/6021ST	RXHH-06	RXHH-06 x 10
6024	RXHH-A05	RXHH-A05 x 10

• External Filter Base RXHF-

Model Cabinet Size	Filter Size In. [mm]	Part Number*	A	B
17	16 x 20 [406 x 508]	RXHF-17	15.70	17.5
21	20 x 20 [508 x 508]	RXHF-21	19.20	21.0
24	25 x 20 [635 x 508]	RXHF-24	22.70	25.5

*Accommodates 1" or 2" filter

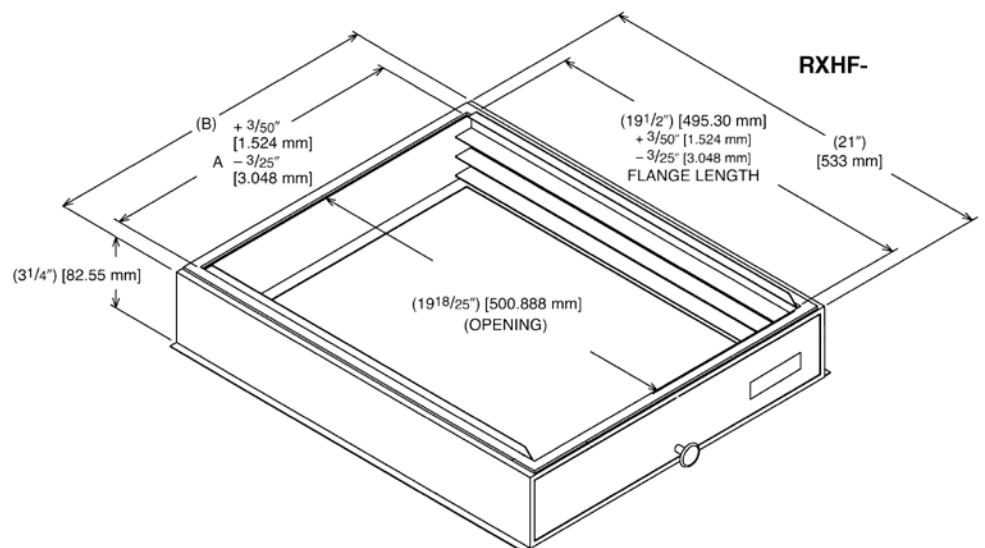
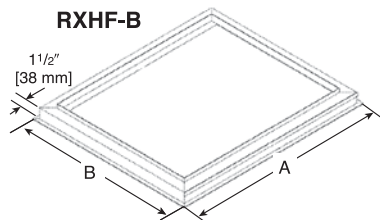

[] Designates Metric Conversions



The new degree of comfort.®

Endeavor™ Line Air Handlers



RH2TZ

Constant Torque Motor

Two-Stage Airflow

Efficiencies: 13.4 to 14.3 SEER2



Table of Contents

Features & Benefits	3
Model Number Identification	4
Dimensional Data	5
Unit Dimensions & Weights	6
Airflow Directional Data	7
Airflow Performance Data	8-12
Electrical Data	13-16
Limited Warranty	20

Features and Benefits

- **Quiet Operation¹:** Provided by a cabinet construction with 1.0 inch of foil faced insulation for quieter sound characteristics
- **Aluminum Indoor Coil Design:** Constructed of aluminum fins bonded to internally grooved aluminum tubing and are more corrosion resistant
- **Versatile 4-Way Convertible Compact Design:** Allow for upflow, downflow, horizontal left and horizontal right applications even in the smallest of spaces
- **Rugged Steel, Compact Cabinet Construction:** Designed for added strength and versatility
- **Field Installed Auxiliary Heater Kits:** Provide exact heat for indoor comfort and include circuit breakers which meet UL and cUL requirements for service disconnect
- **Cabinet Air Leakage at 1-inch H₂O:** When tested in accordance with ASHRAE Standard 193

[] Designates Metric Conversions

¹Based on manufacturer's air handler offering, and the product's airflow stages, motor type and cabinet insulation. Sound levels are also dependent on air handler location and installation.

Air Handlers

<u>R</u>	<u>H</u>	<u>2</u>	<u>T</u>	<u>Z</u>	<u>24</u>	<u>17</u>	<u>S</u>	<u>T</u>	<u>A</u>	<u>N</u>	<u>N</u>	<u>A</u>
Brand	Product Category	Stages of Airflow	Motor Type	Refrigerant	Capacity BTU/HR	Width	Coil Size	Metering Device	Major Series*	Controls	Coil Series	Voltage
R - Rheem	H - Air Handlers	2 - Two-Stage	T - Constant Torque	Z - R-410A	24 - 24,000 [7.03 kW] 36 - 36,000 [10.55 kW] 48 - 48,000 [14.07 kW] 60 - 60,000 [17.58 kW]	17 - 17.5" 21 - 21" 24 - 24.5"	S - Standard Eff.	T - TEV	A - 1st Design	N - Non-comm.	N - N Coil A - A Coil	A - 1ph, 115/60 J - 1ph, 208-240/60

[] Designates Metric Conversions

Available Models
RH2TZ2417STANNA
RH2TZ2417STANNJ
RH2TZ3617STANNA
RH2TZ3617STANNJ
RH2TZ3621MTANAA
RH2TZ3621MTANAJ
RH2TZ3621MTANNA
RH2TZ3621MTANNJ
RH2TZ3621STANNA
RH2TZ3621STANNJ
RH2TZ4821STANAA
RH2TZ4821STANAJ
RH2TZ4821STANNA
RH2TZ4821STANNJ
RH2TZ4824STANNA
RH2TZ4824STANNJ
RH2TZ6021STANAA
RH2TZ6021STANAJ
RH2TZ6024STANNA
RH2TZ6024STANNJ

Standard Equipment
Pre-painted cabinet
Four leg blower mount motor
Slide out blower design for service and maintenance convenience
Traditional open wire element design for heat applications
Field convertible for vertical downflow, horizontal left hand or right hand air supply
3 combustible floor base accessories fit all sizes for downflow installations
Indoor coil design provides low air side pressure drop, high performance and extremely compact size
Expansion valve on indoor coil provides for operation with air conditioning or heat pump
Coils are tested at the factory with an extensive refrigerant leak check
Coils have copper sweat refrigerant connections and utilize chatleff metering device connections
Supply duct flanges
Side or top provisions for field electrical connections
Inside connection for high voltage wiring
Outside connection for low voltage wiring
Concentric knockouts are provided for power connection
Front refrigerant and drain connections

Unit Dimensions

ELECTRICAL CONNECTIONS
MAY EXIT TOP OR EITHER SIDE
HIGH VOLTAGE CONNECTION 7/8" [22.2 mm],
1 3/32" [27.8 mm], 1 3/16" [50 mm] DIA. KNOCKOUTS.

LOW VOLTAGE CONNECTION
5/8" [15.9 mm] AND 7/8" [22.2 mm] KNOCKOUT

AUXILIARY DRAIN CONNECTION
3/4" [19.1 mm] FEMALE PIPE THREAD (NPT)
HORIZONTAL APPLICATION ONLY

PRIMARY DRAIN CONNECTION
3/4" [19.1 mm] FEMALE PIPE THREAD (NPT)

AUXILIARY DRAIN CONNECTION
3/4" [19.1 mm] FEMALE PIPE THREAD (NPT)
UPFLOW/DOWNFLOW APPLICATION ONLY

LIQUID LINE CONNECTION
COPPER (SWEAT)

VAPOR LINE CONNECTION
COPPER (SWEAT)

SUPPLY AIR ↑

NOTE: 24" CLEARANCE REQUIRED IN FRONT OF
UNIT FOR FILTER AND COIL MAINTENANCE.

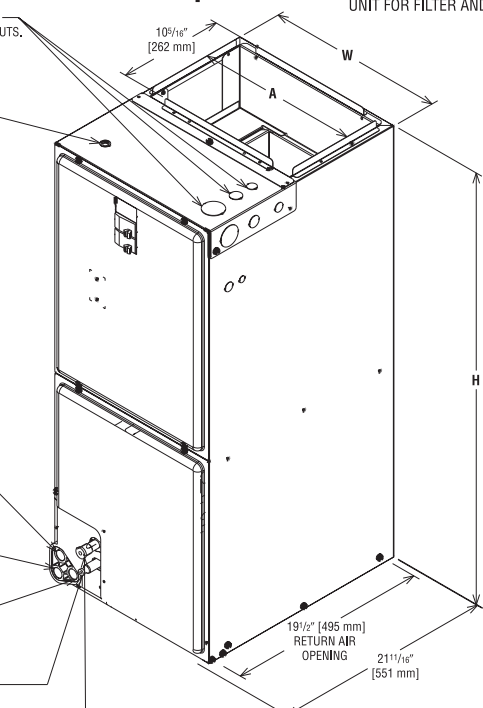

UPFLOW UNIT SHOWN:
UNIT MAY BE INSTALLED UPFLOW, DOWNFLOW,
HORIZONTAL RIGHT OR LEFT AIR SUPPLY.

Return Air Opening Dimensions

Model Cabinet Size	Return Air Opening Width (Inches)	Return Air Opening Depth/Length (Inches)
17	15 7/8	19 3/4
21	19 3/8	19 3/4
24	22 7/8	19 3/4

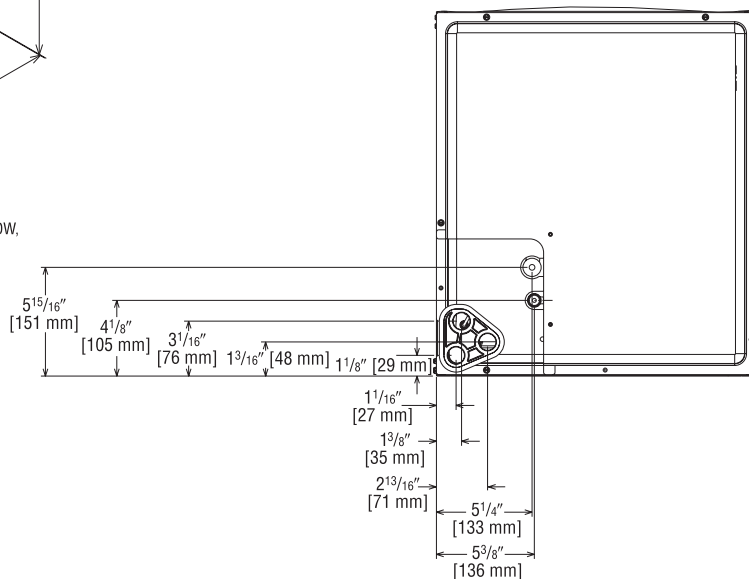

HORIZONTAL ADAPTER KIT

VAPOR LINE CONNECTION

AUXILIARY HORIZONTAL DRAIN CONNECTION

PRIMARY DRAIN CONNECTION

AUXILIARY UPFLOW/DOWNFLOW DRAIN CONNECTION

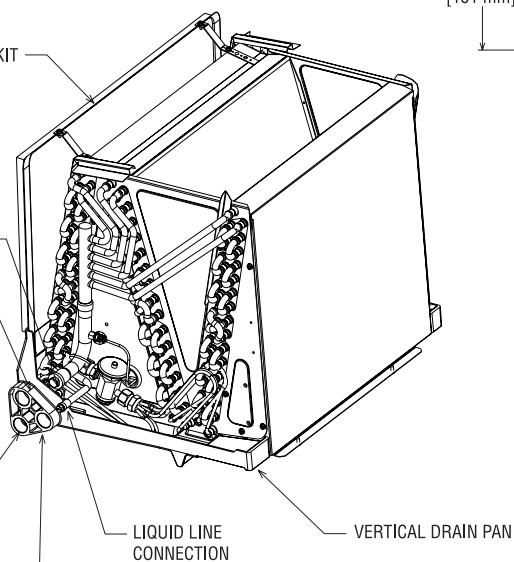

UPFLOW UNIT SHOWN:
UNIT MAY BE INSTALLED UPFLOW,
DOWNFLOW, HORIZONTAL RIGHT
OR LEFT AIR SUPPLY.

[] Designates Metric Conversions
() Designates Unit with Double Coil Cabinet

Unit Dimensions & Weights

Model Size RH2TZ	Refrigerant Connections Sweat (In.) [mm] ID		Unit Width "W" In. [mm]	Unit Height "H" In. [mm]	Unit Weight/Shipping Weight (Lbs.) [kg]
	Liquid	Vapor			Unit With Coil (Max. KW)
2417ST	3/8 [9.53]	3/4 [19.05]	17 1/2 [445]	42 1/2 [1080]	92/106 [42/48]
3617ST	3/8 [9.53]	3/4 [19.05]	17 1/2 [445]	42 1/2 [1080]	96/110 [44/50]
3621ST	3/8 [9.53]	3/4 [19.05]	21 [533]	42 1/2 [1080]	111/126 [50/57]
3621MT**N	3/8 [9.53]	7/8 [22.23]	21 [533]	50 1/2 [1282]	126/142 [57/64]
3621MT**A	3/8 [9.53]	7/8 [22.23]	21 [533]	57 [1448]	137/149 [62/68]
4821ST**N	3/8 [9.53]	7/8 [22.23]	21 [533]	50 1/2 [1282]	128/144 [56/65]
4821ST**A	3/8 [9.53]	7/8 [22.23]	21 [533]	57 [1448]	139/151 [63/68]
4824ST**N	3/8 [9.53]	7/8 [22.23]	24 1/2 [622]	55 1/2 [1410]	128/146 [58/66]
6021ST**A	3/8 [9.53]	7/8 [22.23]	21 [533]	57 [1448]	139/151 [63/68]
6024ST	3/8 [9.53]	7/8 [22.23]	24 1/2 [622]	55 1/2 [1410]	161/178 [73/81]

[] Designates Metric Conversions

Airflow Directional Data

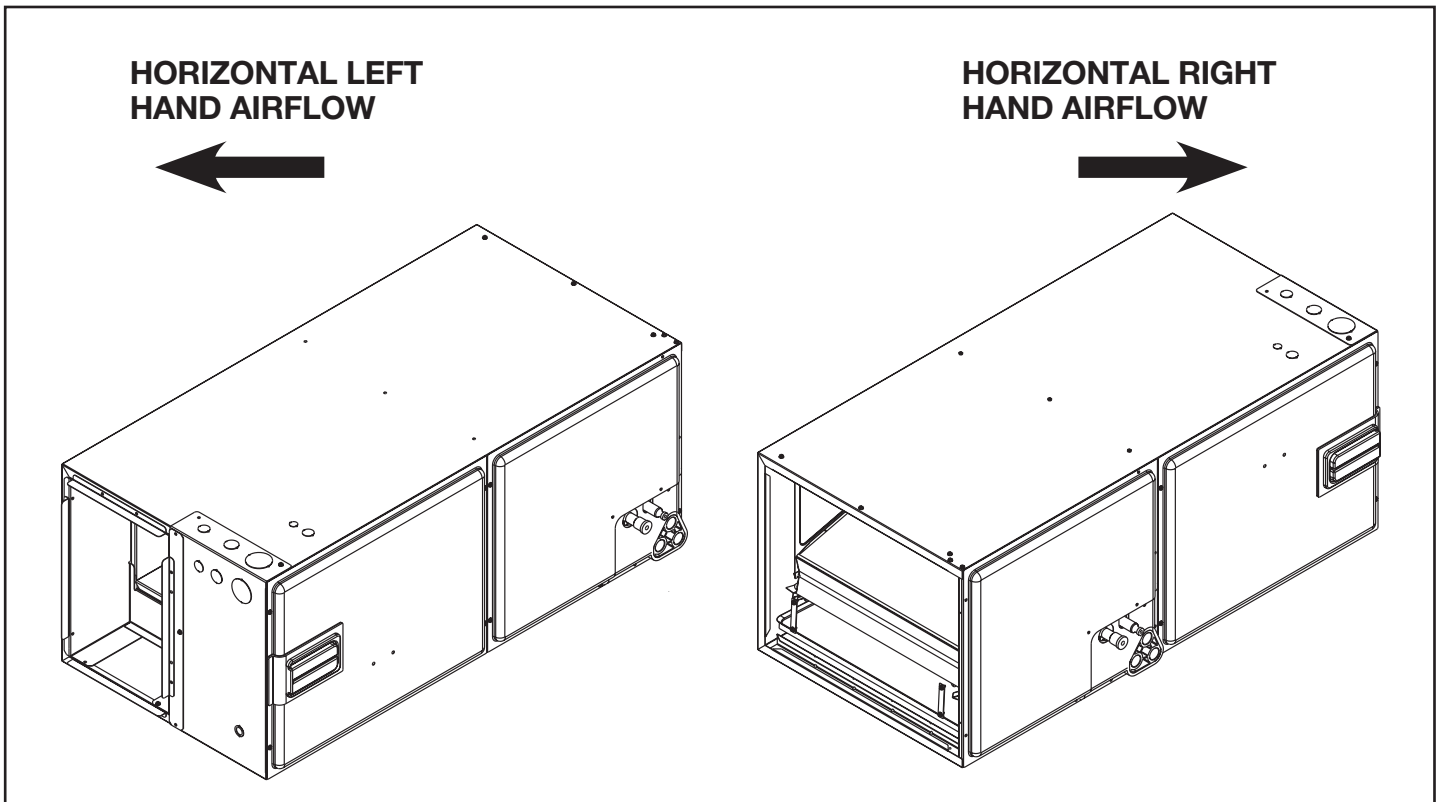
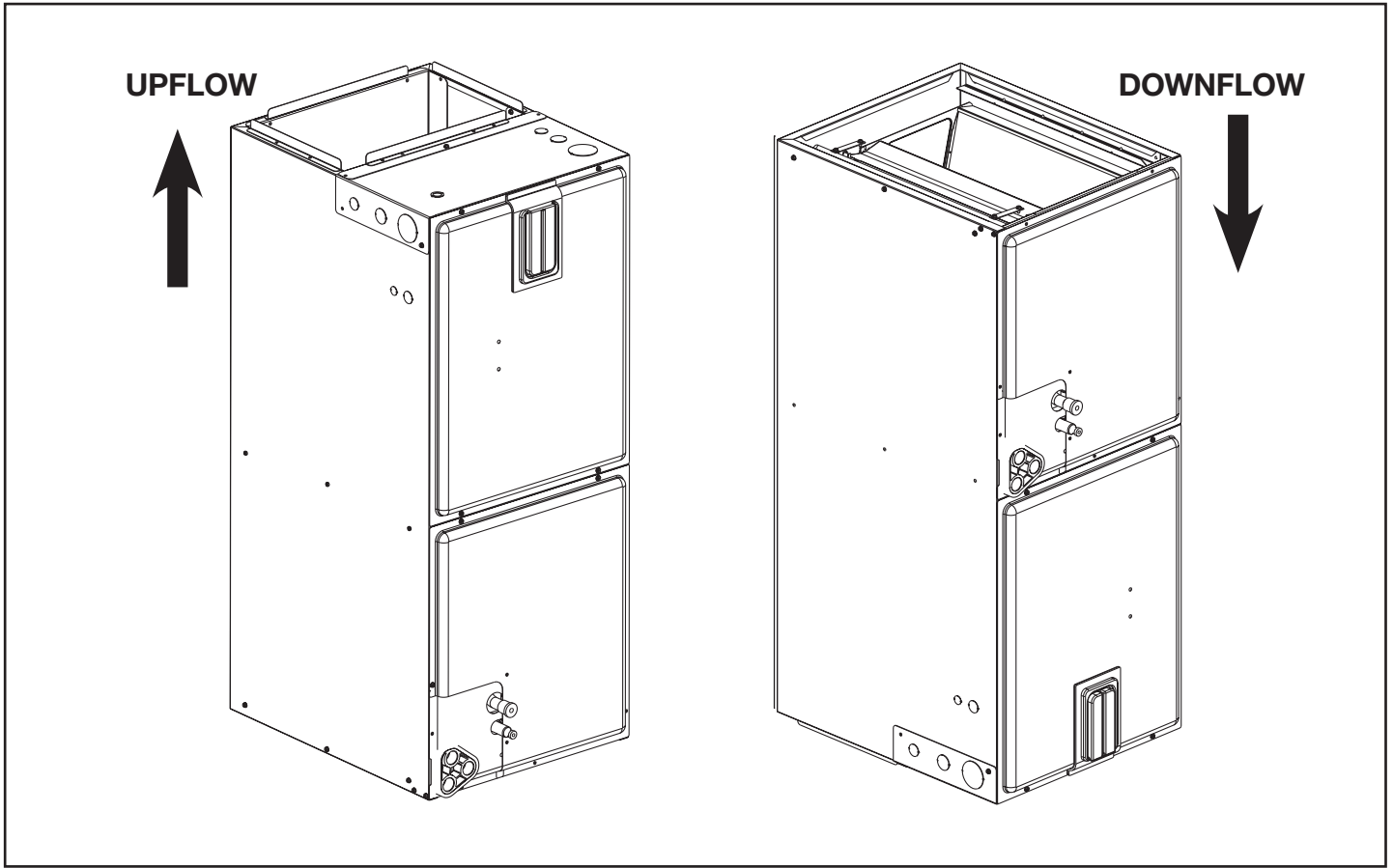

Airflow Performance

Airflow performance data is based on cooling performance with a coil and no filter in place. Select performance table for appropriate unit size, voltage and number of electric heaters to be used. Make sure external static applied to unit allows operation within the minimum and maximum limits shown in

table below for both cooling and electric heat operation. For optimum blower performance, operate the unit in the .3 [8 mm] to .7 inches [18 mm] W.C. external static range. Units with coils should be applied with a minimum of .1 inch [3 mm] W.C. external static range.

Airflow Operating Limits

Cabinet Width	17		17/21		21			24	
Cooling BTUH x 1,000 Cooling Tons Nominal	18 1.5	24 2	30 2.5	36 3	42 3.5	48 4	60 5	48 4	60 5
Heat Pump or Air Conditioning Maximum Heat/Cool CFM [L/s] (37.5 CFM [18 L/s]/1,000 BTUH) (450 CFM [212 L/s]/Ton Nominal)	675 [319]	900 [425]	1125 [531]	1350 [637]	1575 [743]	1800 [850]	1925 [907]	1800 [850]	1930* [911]
Heat Pump or Air Conditioning Nominal Heat/Cool CFM [L/s] (33.3 CFM [16 L/s]/1,000 BTUH) (400 CFM [189 L/s]/Ton Nominal)	600 [283]	800 [378]	1000 [472]	1200 [566]	1400 [661]	1600 [755]	1750 [826]	1550 [732]	1800* [850]
Heat Pump or Air Conditioning Minimum Heat/Cool CFM [L/s] (30.0 CFM [14 L/s]/1,000 BTUH) (360 CFM [170 L/s]/Ton Nominal)	540 [255]	720 [340]	900 [425]	1080 [510]	1260 [595]	1440 [680]	1575 [743]	1440 [680]	1620* [765]
Maximum kW Electric Heating & Minimum Electric Heat CFM [L/s]	487 [230] 80 [26.7]	617 [291] 63 [17.2]	814 [384] 66 [18.9]	1054 [497] 51 [10.6]	1171 [553] 49 [9.4]	1502 [709] 50 [10]	1502 [709] 50 [10]	1502 [709] 50 [10]	1666 [786] 54 [12.2]
Maximum Electric Heat Rise °F [°C]	80 [26.7]	63 [17.2]	66 [18.9]	51 [10.6]	49 [9.4]	50 [10]	50 [10]	50 [10]	54 [12.2]

[] Designates Metric Conversions

115V/208V/240V Airflow Performance Data – RH2TZ (Constant Torque (ECM) Motor)

Model No. RH2TZ	Tonnage Application	Motor Speed From Factory	Blower Size/ Motor HP [W] # of Speed	Motor Speed	CFM/RPM/WATTS — Dry Coil—No Filter										
					External Static Pressure Inches of W.C.										
					0.1	0.2	0.3	0.4	0.5	0.6	0.7	0.8	0.9	1	
2417ST No Heater	1.5 Ton	5	10x8 1/3 HP [373] 5 Speed	2	CFM	835	664	501	434	362	294	—	—	—	—
					RPM	570	581	617	687	746	814	—	—	—	—
					Watts	89	70	59	66	72	78	—	—	—	—
				3	CFM	—	—	—	—	649	589	545	489	441	383
					RPM	—	—	—	—	791	851	899	951	990	1049
					Watts	—	—	—	—	121	129	136	144	149	159
2417ST with 18 kW Heater	1.5 Ton	5	10x8 1/3 HP [373] 5 Speed	2	CFM	810	644	486	421	352	285	—	—	—	—
					RPM	599	610	648	721	783	854	—	—	—	—
					Watts	96	77	65	71	78	85	—	—	—	—
				3	CFM	—	—	—	—	629	572	528	474	428	372
					RPM	—	—	—	—	830	894	944	998	1040	1101
					Watts	—	—	—	—	132	141	148	157	163	174
2417ST No Heater	2 Ton	5	10x8 1/3 HP [373] 5 Speed	4	CFM	829	662	555	482	430	363	—	—	—	—
					RPM	573	584	635	705	757	814	—	—	—	—
					Watts	88	70	68	75	80	86	—	—	—	—
				5	CFM	—	—	—	—	799	759	722	670	628	583
					RPM	—	—	—	—	830	875	920	975	1016	1057
					Watts	—	—	—	—	164	172	181	190	199	206
2417ST with 18 kW Heater	2 Ton	5	10x8 1/3 HP [373] 5 Speed	4	CFM	805	642	538	467	417	352	—	—	—	—
					RPM	602	613	666	741	795	855	—	—	—	—
					Watts	96	76	74	82	87	94	—	—	—	—
				5	CFM	—	—	—	—	775	736	701	650	609	566
					RPM	—	—	—	—	871	919	966	1024	1066	1110
					Watts	—	—	—	—	178	187	197	207	217	225
3617ST No Heater	2.5 Ton	5	10x10 1/2 HP [373] 5 Speed	2	CFM	857	721	665	594	539	473	—	—	—	—
					RPM	586	596	648	712	768	827	—	—	—	—
					Watts	91	77	83	91	106	114	—	—	—	—
				3	CFM	—	—	—	—	943	902	859	814	771	723
					RPM	—	—	—	—	859	899	920	955	995	1030
					Watts	—	—	—	—	204	212	221	230	240	249
3617ST with 18 kW Heater	2.5 Ton	5	10x10 1/2 HP [373] 5 Speed	2	CFM	831	700	645	576	523	459	—	—	—	—
					RPM	615	625	680	748	807	869	—	—	—	—
					Watts	99	84	90	99	116	124	—	—	—	—
				3	CFM	—	—	—	—	914	875	833	790	748	701
					RPM	—	—	—	—	902	944	966	1003	1045	1082
					Watts	—	—	—	—	222	231	241	251	261	271
3617ST No Heater	3 Ton	5	10x10 1/2 HP [373] 5 Speed	4	CFM	855	762	705	655	597	536	—	—	—	—
					RPM	588	617	662	716	777	831	—	—	—	—
					Watts	103	87	93	100	116	115	—	—	—	—
				5	CFM	—	—	—	—	1094	1056	1016	974	937	901
					RPM	—	—	—	—	895	927	953	991	1021	1050
					Watts	—	—	—	—	270	280	287	299	308	317

[] Designates Metric Conversions

115V/208V/240V Airflow Performance Data – RH2TZ (Constant Torque (ECM) Motor) (Con't.)

Model No. RH2TZ	Tonnage Application	Motor Speed From Factory	Blower Size/ Motor HP [W] # of Speed	Motor Speed	CFM/RPM/WATTS — Dry Coil—No Filter										
					External Static Pressure Inches of W.C.										
					0.1	0.2	0.3	0.4	0.5	0.6	0.7	0.8	0.9	1	
3617ST with 18 kW Heater	3 Ton	5	10x10 1/2 HP [373] 5 Speed	4	CFM	829	739	683	635	579	520	—	—	—	—
					RPM	618	647	696	752	816	872	—	—	—	—
					Watts	112	95	101	109	126	125	—	—	—	—
				5	CFM	—	—	—	—	1061	1024	986	945	909	874
					RPM	—	—	—	—	940	973	1001	1040	1072	1102
					Watts	—	—	—	—	294	305	313	326	336	345
3621ST No Heater	2.5 Ton	5	10x10 1/2 HP [373] 5 Speed	2	CFM	987	793	662	611	549	489	—	—	—	—
					RPM	591	598	640	700	755	817	—	—	—	—
					Watts	97	74	66	75	80	89	—	—	—	—
				3	CFM	—	—	—	—	941	898	852	809	755	712
					RPM	—	—	—	—	821	864	910	955	1006	1042
					Watts	—	—	—	—	171	179	188	196	207	216
3621ST with 18 kW Heater	2.5 Ton	5	10x10 1/2 HP [373] 5 Speed	2	CFM	957	763	632	581	519	459	—	—	—	—
					RPM	616	623	665	725	780	842	—	—	—	—
					Watts	92	69	61	70	75	84	—	—	—	—
				3	CFM	—	—	—	—	911	868	822	779	725	682
					RPM	—	—	—	—	846	889	935	980	1031	1067
					Watts	—	—	—	—	166	174	183	191	202	211
3621ST No Heater	3 Ton	5	10x10 1/2 HP [373] 5 Speed	4	CFM	983	808	706	654	580	529	—	—	—	—
					RPM	595	600	623	641	695	770	—	—	—	—
					Watts	96	75	72	79	87	92	—	—	—	—
				5	CFM	—	—	—	—	1099	1058	1017	975	937	905
					RPM	—	—	—	—	859	895	939	983	1020	1054
					Watts	—	—	—	—	223	231	241	251	263	276
3621ST with 18 kW Heater	3 Ton	5	10x10 1/2 HP [373] 5 Speed	4	CFM	953	778	676	624	550	499	—	—	—	—
					RPM	620	625	648	666	720	795	—	—	—	—
					Watts	91	70	67	74	82	87	—	—	—	—
				5	CFM	—	—	—	—	1069	1028	987	945	907	875
					RPM	—	—	—	—	884	920	964	1008	1045	1079
					Watts	—	—	—	—	218	226	236	246	258	271
4821ST***N No Heater	3.5 Ton	5	10x10 3/4 HP [373] 5 Speed	2	CFM	892	817	737	632	564	487	—	—	—	—
					RPM	611	660	718	817	864	910	—	—	—	—
					Watts	81	89	96	108	114	120	—	—	—	—
				3	CFM	—	—	—	—	1336	1290	1240	1198	1147	1085
					RPM	—	—	—	—	1006	1048	1084	1121	1170	1235
					Watts	—	—	—	—	341	356	367	379	396	421
4821ST***N with 20 kW Heater	3.5 Ton	5	10x10 3/4 HP [373] 5 Speed	2	CFM	892	817	737	632	564	487	—	—	—	—
					RPM	611	660	718	817	864	910	—	—	—	—
					Watts	81	89	96	108	114	120	—	—	—	—
				3	CFM	—	—	—	—	1336	1290	1240	1198	1147	1085
					RPM	—	—	—	—	1006	1048	1084	1121	1170	1235
					Watts	—	—	—	—	341	356	367	379	396	421

[] Designates Metric Conversions

115V/208V/240V Airflow Performance Data – RH2TZ (Constant Torque (ECM) Motor) (Con't.)

Model No. RH2TZ	Tonnage Application	Motor Speed From Factory	Blower Size/ Motor HP [W] # of Speed	Motor Speed	CFM/RPM/WATTS — Dry Coil—No Filter										
					External Static Pressure Inches of W.C.										
					0.1	0.2	0.3	0.4	0.5	0.6	0.7	0.8	0.9	1	
4821ST***N No Heater	4 Ton	5	10x10 3/4 HP [373] 5 Speed	4	CFM	1106	1032	973	901	819	712	—	—	—	—
					RPM	698	727	770	821	893	972	—	—	—	—
					Watts	129	134	142	150	163	178	—	—	—	—
				5	CFM	—	—	—	—	1472	1430	1392	1349	1308	1272
					RPM	—	—	—	—	1068	1104	1134	1171	1205	1243
					Watts	—	—	—	—	430	445	457	473	487	504
4821ST***N with 25 kW Heater	4 Ton	5	10x10 3/4 HP [373] 5 Speed	4	CFM	1106	1032	973	901	819	712	—	—	—	—
					RPM	698	727	770	821	893	972	—	—	—	—
					Watts	129	134	142	150	163	178	—	—	—	—
				5	CFM	—	—	—	—	1472	1430	1392	1349	1308	1272
					RPM	—	—	—	—	1068	1104	1134	1171	1205	1243
					Watts	—	—	—	—	430	445	457	473	487	504
4824ST No Heater	3.5 Ton	5	10x10 3/4 HP [373] 5 Speed	2	CFM	964	882	809	676	581	464	—	—	—	—
					RPM	445	501	552	610	651	698	—	—	—	—
					Watts	79	88	96	104	111	113	—	—	—	—
				3	CFM	—	—	—	—	1372	1312	1257	1201	1126	1035
					RPM	—	—	—	—	765	803	837	875	910	948
					Watts	—	—	—	—	292	305	317	330	342	354
4824ST with 20 kW Heater	3.5 Ton	5	10x10 3/4 HP [373] 5 Speed	2	CFM	934	852	779	646	551	434	—	—	—	—
					RPM	470	526	577	635	676	723	—	—	—	—
					Watts	74	83	91	99	106	108	—	—	—	—
				3	CFM	—	—	—	—	1342	1282	1227	1171	1096	1005
					RPM	—	—	—	—	790	828	862	900	935	973
					Watts	—	—	—	—	287	300	312	325	337	349
4824ST No Heater	4 Ton	5	10x10 3/4 HP [373] 5 Speed	4	CFM	1152	1080	1004	926	837	734	—	—	—	—
					RPM	493	539	587	636	687	726	—	—	—	—
					Watts	113	122	131	141	151	159	—	—	—	—
				5	CFM	—	—	—	—	1507	1459	1412	1360	1308	1241
					RPM	—	—	—	—	798	833	861	894	922	960
					Watts	—	—	—	—	350	364	378	389	400	415
4824ST with 20 kW Heater	4 Ton	5	10x10 3/4 HP [373] 5 Speed	4	CFM	1122	1050	974	896	807	704	—	—	—	—
					RPM	518	564	612	661	712	751	—	—	—	—
					Watts	108	117	126	136	146	154	—	—	—	—
				5	CFM	—	—	—	—	1477	1429	1382	1330	1278	1211
					RPM	—	—	—	—	823	858	886	919	947	985
					Watts	—	—	—	—	345	359	373	384	395	410
6024ST No Heater	4.5 Ton	5	11x11 3/4 HP [373] 5 Speed	2	CFM	1321	1127	914	512	398	321	—	—	—	—
					RPM	567	573	579	588	629	667	—	—	—	—
					Watts	164	138	115	78	81	86	—	—	—	—
				3	CFM	—	—	—	—	1511	1467	1414	1356	1301	1243
					RPM	—	—	—	—	822	850	879	906	937	968
					Watts	—	—	—	—	375	386	397	405	418	431

[] Designates Metric Conversions

115V/208V/240V Airflow Performance Data – RH2TZ (Constant Torque (ECM) Motor) (Con't.)

Model No. RH2TZ	Tonnage Application	Motor Speed From Factory	Blower Size/ Motor HP [W] # of Speed	Motor Speed	CFM/RPM/WATTS — Dry Coil—No Filter										
					External Static Pressure Inches of W.C.										
					0.1	0.2	0.3	0.4	0.5	0.6	0.7	0.8	0.9	1	
6024ST with 25 kW Heater	4.5 Ton	5	11x11 3/4 HP [373] 5 Speed	2	CFM	1281	1093	886	497	386	311	—	—	—	—
					RPM	595	602	608	618	660	700	—	—	—	—
					Watts	179	150	126	85	88	93	—	—	—	—
				3	CFM	—	—	—	—	1466	1423	1372	1315	1262	1205
					RPM	—	—	—	—	864	893	923	951	984	1016
					Watts	—	—	—	—	408	420	432	442	456	470
6024ST No Heater	5 Ton	5	11x11 3/4 HP [373] 5 Speed	4	CFM	1367	1193	1097	1032	957	869	—	—	—	—
					RPM	583	588	622	661	700	746	—	—	—	—
					Watts	176	154	156	165	174	184	—	—	—	—
				5	CFM	—	—	—	—	1877	1837	1797	1754	1707	1673
					RPM	—	—	—	—	924	946	967	995	1018	1045
					Watts	—	—	—	—	602	614	628	643	656	673
6024ST with 30 kW Heater	5 Ton	5	11x11 3/4 HP [373] 5 Speed	4	CFM	1326	1157	1064	1001	928	843	—	—	—	—
					RPM	612	618	653	694	735	783	—	—	—	—
					Watts	192	167	170	180	190	200	—	—	—	—
				5	CFM	—	—	—	—	1821	1781	1743	1701	1656	1623
					RPM	—	—	—	—	970	994	1016	1045	1069	1097
					Watts	—	—	—	—	656	670	684	701	714	734
6021ST No Heater	4.5 Ton	5	11x11 3/4 HP [373] 5 Speed	2	CFM	1120	1061	997	875	819	777	—	—	—	—
					RPM	657	710	773	859	892	917	—	—	—	—
					Watts	133	143	154	170	176	180	—	—	—	—
				3	CFM	—	—	—	—	1515	1464	1416	1363	1295	1248
					RPM	—	—	—	—	1047	1089	1134	1175	1228	1259
					Watts	—	—	—	—	439	454	471	486	507	519
6021ST with 25 kW Heater	4.5 Ton	5	11x11 3/4 HP [373] 5 Speed	2	CFM	1080	1021	957	835	779	737	—	—	—	—
					RPM	682	735	798	884	917	942	—	—	—	—
					Watts	128	138	149	165	171	175	—	—	—	—
				3	CFM	—	—	—	—	1475	1424	1376	1323	1255	1208
					RPM	—	—	—	—	1072	1114	1159	1200	1253	1284
					Watts	—	—	—	—	434	449	466	481	502	514
6021ST No Heater	5 Ton	5	11x11 3/4 HP [373] 5 Speed	4	CFM	1223	1171	1113	1057	967	892	—	—	—	—
					RPM	702	750	807	859	927	966	—	—	—	—
					Watts	167	178	190	201	216	224	—	—	—	—
				5	CFM	—	—	—	—	1896	1861	1829	1790	1730	1568
					RPM	—	—	—	—	1180	1210	1240	1277	1301	1302
					Watts	—	—	—	—	727	742	759	780	771	683
6021ST with 30 kW Heater	5 Ton	5	11x11 3/4 HP [373] 5 Speed	4	CFM	1183	1131	1073	1017	927	852	—	—	—	—
					RPM	727	775	832	884	952	991	—	—	—	—
					Watts	162	173	185	196	211	219	—	—	—	—
				5	CFM	—	—	—	—	1856	1821	1789	1750	1690	1528
					RPM	—	—	—	—	1205	1235	1265	1302	1326	1327
					Watts	—	—	—	—	722	737	754	775	766	678

[] Designates Metric Conversions

Electrical Data – Blower Motor Only – No Electric Heat RH2TZ

Model RH2TZ	Voltage	Phase*	Hertz	HP [W]	RPM	Speeds	Motor Amps.	Minimum Circuit Ampacity	Maximum Overcurrent Protection
2417S	115	1	60	1/3 [249]	300-1100	4	2.7	4	15
3617S/3621M				1/2 [373]	300-1100	4	3.4	5	15
4821S/4824S				3/4 [559]	300-1100	4	6.5	9	15
6021S/6024S				3/4 [559]	300-1100	4	8.0	10	15
2417S	208/240	1	60	1/3 [249]	300-1100	4	1.8	3	15
3617S/3621M				1/2 [373]	300-1100	4	2.4	3	15
4821S/4821M/4824S				3/4 [559]	300-1100	4	3.7	5	15
6021S/6024S				3/4 [559]	300-1100	4	5.6	7	15

[] Designates Metric Conversions

Electrical Data – With Electric Heat RH2TZ

Installation of the U.L. Listed original equipment manufacturer provided heater kits listed in the following table is recommended for all auxiliary heating requirements.

Model RH2TZ	Heater Model Number	Heater kW (208/240V)	Ph/Hz	No. Elements - kW per	Type Supply Circuit Single Circuit Multiple Circuit	Heater Amps.	Motor Amps	Minimum Circuit Ampacity	Maximum Overcurrent Protection
2417S	RXBH-17?03J-1	2.25/3.0	1/60	1-3.0	SINGLE	10.8/12.5	1.8	16/18	20/20
	RXBH-1724?03J-1	2.25/3.0	1/60	1-3.0	SINGLE	10.8/12.5	1.8	16/18	20/20
	RXBH-1724?05J-1	3.6/4.8	1/60	1-4.8	SINGLE	17.3/20.0	1.8	24/28	30/30
	RXBH-1724?07J-1	5.4/7.2	1/60	2-3.6	SINGLE	26.0/30.0	1.8	35/40	40/40
	RXBH-1724?10J-1	7.2/9.6	1/60	2-4.8	SINGLE	34.6/40.0	1.8	46/53	50/60
	RXBH-1724A13J-1	9.4/12.5	1/60	3/4/17	SINGLE	45.1/52.1	1.8	59/68	60/70
	RXBH-1724A13J-1	3.1/4.2	1/60	1/4/17	MULTIPLE CKT 1	15.0/17.4	1.8	21/24	30/30
		6.3/8.3	1/60	2/4/17	MULTIPLE CKT 2	30.1/34.7	0.0	38/44	40/50
	RXBH-1724A07C-1	5.4/7.2	3/60	3-2.4	SINGLE	15.0/17.3	1.8	21/24	30/30
	RXBH-1724A10C-1	7.2/9.6	3/60	3-3.2	SINGLE	20.0/23.1	1.8	28/32	30/40
RXBH-1724A13C-1	9.4/12.5	3/60	3/4/17	SINGLE	26.1/30.1	1.8	35/40	40/40	
3617S	RXBH-17?03J-1	2.25/3.0	1/60	1-3.0	SINGLE	10.8/12.5	2.8	17/20	20/20
3617S/ 3621M	RXBH-1724?03J-1	2.25/3.0	1/60	1-3.0	SINGLE	10.8/12.5	2.8	17/20	20/20
	RXBH-1724?05J-1	3.6/4.8	1/60	1-4.8	SINGLE	17.3/20.0	2.8	26/29	30/30
	RXBH-1724?07J-1	5.4/7.2	1/60	2-3.6	SINGLE	26.0/30.0	2.8	36/41	40/50
	RXBH-1724?10J-1	7.2/9.6	1/60	2-4.8	SINGLE	34.6/40.0	2.8	47/54	50/60
	RXBH-1724A13J-1	9.4/12.5	1/60	3/4/17	SINGLE	45.1/52.1	2.8	60/69	60/70
	RXBH-1724A13J-1	3.1/4.2	1/60	1/4/17	MULTIPLE CKT 1	15.0/17.4	2.8	23/26	30/30
		6.3/8.3	1/60	2/4/17	MULTIPLE CKT 2	30.1/34.7	0.0	38/44	40/50
	RXBH-1724A15J-1	10.8/14.4	1/60	3-4.8	SINGLE	51.9/60.0	2.8	69/79	70/80
	RXBH-1724A15J-1	3.6/4.8	1/60	1-4.8	MULTIPLE CKT 1	17.3/20.0	2.8	26/29	30/30
		7.2/9.6	1/60	2-4.8	MULTIPLE CKT 2	34.6/40.0	0.0	44/50	50/50
	RXBH-1724A18J-1	12.8/17.0	1/60	3/5/68	SINGLE	61.6/70.8	2.8	81/92	90/100
	RXBH-1724A18J-11	4.3/5.7	1/60	1/5/68	MULTIPLE CKT 1	20.5/23.6	2.8	30/33	30/40
		8.5/11.3	1/60	2/5/68	MULTIPLE CKT 2	41.1/47.2	0.0	52/59	60/60
	RXBH-1724A07C-1	5.4/7.2	3/60	3-2.4	SINGLE	15.0/17.3	2.8	23/26	30/30
	RXBH-1724A10C-1	7.2/9.6	3/60	3-3.2	SINGLE	20.0/23.1	2.8	29/33	30/40
	RXBH-1724A13C-1	9.4/12.5	3/60	3/4/17	SINGLE	26.1/30.1	2.8	37/42	40/50

Electrical Data – With Electric Heat RH2TZ (Con't.)

Model RH2TZ	Heater Model Number	Heater kW (208/240V)	Ph/Hz	No. Elements - kW per	Type Supply Circuit Single Circuit Multiple Circuit	Heater Amps.	Motor Amps	Minimum Circuit Ampacity	Maximum Overcurrent Protection
3617S	RXBH-17A07D-1	7.2	3/60	3-2.4	SINGLE	8.7	2.8	15/15	20/20
	RXBH-17A10D-1	9.6	3/60	3-3.2	SINGLE	11.6	2.8	18/18	20/20
	RXBH-17A15D-1	14.4	3/60	3-4.8	SINGLE	17.3	2.8	26/26	30/30
	RXBH-17A18D-1	17.0	3/60	3/5/68	SINGLE	20.4	2.8	29/29	30/30
4821S/ 4821M/ 4824S	RXBH-1724?05J-1	3.6/4.8	1/60	1-4.8	SINGLE	17.3/20.0	4.0	27/30	30/30
	RXBH-1724?07J-1	5.4/7.2	1/60	2-3.6	SINGLE	26.0/30.0	4.0	38/43	40/50
	RXBH-1724?10J-1	7.2/9.6	1/60	2-4.8	SINGLE	34.6/40.0	4.0	49/55	50/60
	RXBH-1724A15J-1	10.8/14.4	1/60	3-4.8	SINGLE	51.9/60.0	4.0	70/80	70/80
	RXBH-1724A15J-1	3.6/4.8	1/60	1-4.8	MULTIPLE CKT 1	17.3/20.0	4.0	27/30	30/30
		7.2/9.6	1/60	2-4.8	MULTIPLE CKT 2	34.6/40.0	0.0	44/50	50/50
	RXBH-1724A18J-1	12.8/17.0	1/60	3/5/68	SINGLE	61.6/70.8	4.0	82/94	90/100
	RXBJ-1724A18J-1	4.3/5.7	1/60	1/5/68	MULTIPLE CKT 1	20.5/23.6	4.0	31/35	40/40
		8.5/11.3	1/60	2/5/68	MULTIPLE CKT 2	41.1/47.2	0.0	52/59	60/60
	RXBH-24A20J-1	14.4/19.2	1/60	4-4.8	SINGLE	69.2/80	4.0	92/105	100/110
	RXBH-24A20J-1	7.2/9.6	1/60	2-4.8	MULTIPLE CKT 1	34.6/40.0	4.0	49/55	50/60
		7.2/9.6	1/60	2-4.8	MULTIPLE CKT 2	34.6/40.0	0.0	44/50	50/50
	RXBH-24A25J-1	18.0/24.0	1/60	6-4.0	SINGLE	86.4/99.9	4.0	113/130	120/130
	RXBH-24A25J-1	6.0/8.0	1/60	2-4.0	MULTIPLE CKT 1	28.8/33.3	4.0	41/47	50/50
		6.0/8.0	1/60	2-4.0	MULTIPLE CKT 2	28.8/33.3	0.0	36/42	40/50
		6.0/8.0	1/60	2-4.0	MULTIPLE CKT 3	28.8/33.3	0.0	36/42	40/50
	RXBH-1724A07C-1	5.4/7.2	3/60	3-2.4	SINGLE	15.0/17.3	4.0	24/27	30/30
	RXBH-1724A10C-1	7.2/9.6	3/60	3-3.2	SINGLE	20.0/23.1	4.0	30/34	30/40
	RXBH-1724A15C-1	10.8/14.4	3/60	3-4.8	SINGLE	30.0/34.6	4.0	43/49	50/50
	RXBH-1724A18C-1	12.8/17.0	3/60	3/5/68	SINGLE	35.6/41.0	4.0	50/57	50/60
	RXBH-24A20C-1	14.4/19.2	3/60	6-3.2	SINGLE	40.0/46.2	4.0	55/63	60/70
	RXBH-24A20C-1	7.2/9.6	3/60	3-3.2	MULTIPLE CKT 1	20.0/23.1	4.0	30/34	30/40
		7.2/9.6	3/60	3-3.2	MULTIPLE CKT 2	20.0/23.1	0.0	25/29	30/30
	RXBH-24A25C-1	18.0/24.0	3/60	6-4.0	SINGLE	50.0/57.8	4.0	68/78	70/80
	RXBH-24A25C-1	9.0/12.0	3/60	3-4.0	MULTIPLE CKT 1	25.0/28.9	4.0	37/42	40/50
		9.0/12.0	3/60	3-4.0	MULTIPLE CKT 2	25.0/28.9	0.0	32/37	40/40
	RXBH-24A07D-1	7.2	3/60	3-2.4	SINGLE	8.7	4.0	16/16	20/20
	RXBH-24A10D-1	9.6	3/60	3-3.2	SINGLE	11.6	4.0	20/20	20/20
	RXBH-24A15D-1	14.4	3/60	3-4.8	SINGLE	17.3	4.0	27/27	30/30
	RXBH-24A18D-1	17.0	3/60	6/2/84	SINGLE	20.4	4.0	31/31	40/40
RXBH-24A20D-1	19.2	3/60	6-3.2	SINGLE	23.2	4.0	34/34	40/40	
RXBH-24A25D-1	24.0	3/60	6-4.0	SINGLE	28.8	4.0	41/41	50/50	

Electrical Data – With Electric Heat RH2TZ (Con't.)

Model RH2TZ	Heater Model Number	Heater kW (208/240V)	Ph/Hz	No. Elements - kW per	Type Supply Circuit Single Circuit Multiple Circuit	Heater Amps.	Motor Amps	Minimum Circuit Ampacity	Maximum Overcurrent Protection
4824S 6021S 6024S	RXBH-1724?05J-1	3.6/4.8	1/60	1-4.8	SINGLE	17.3/20.0	4.7	28/31	30/40
	RXBH-1724?07J-1	5.4/7.2	1/60	2-3.6	SINGLE	26.0/30.0	4.7	39/44	40/50
	RXBH-1724?10J-1	7.2/9.6	1/60	2-4.8	SINGLE	34.6/40.0	4.7	50/56	50/60
	RXBH-1724A15J-1	10.8/14.4	1/60	3-4.8	SINGLE	51.9/60.0	4.7	71/81	80/90
	RXBH-1724A15J-1	3.6/4.8	1/60	1-4.8	MULTIPLE CKT 1	17.3/20.0	4.7	28/31	30/40
		7.2/9.6	1/60	2-4.8	MULTIPLE CKT 2	34.6/40.0	4.7	50/56	50/60
	RXBH-1724A18J-1	12/8/17	1/60	3/5/68	SINGLE	61.6/70.8	4.7	83/95	90/100
	RXBH-1724A18J-1	4.3/5.7	1/60	1/5/68	MULTIPLE CKT 1	20.5/23.6	4.7	32/36	40/40
		8.5/11.3	1/60	2/5/68	MULTIPLE CKT 2	41.1/47.2	0.0	52/59	60/60
	RXBH-24A20J-1	14.4/19.2	1/60	4-4.8	SINGLE	69.2/80	4.7	93/106	100/110
	RXBH-24A20J-1	7.2/9.6	1/60	2-4.8	MULTIPLE CKT 1	34.6/40.0	4.7	50/56	50/60
		7.2/9.6	1/60	2-4.8	MULTIPLE CKT 2	34.6/40.0	0.0	44/50	50/50
	RXBH-24A25J-1	18.0/24.0	1/60	6-4.0	SINGLE	86.4/99.9	4.7	114/131	120/140
	RXBH-24A25J-1	6.0/8.0	1/60	2-4.0	MULTIPLE CKT 1	28.8/33.3	4.7	42/48	50/50
		6.0/8.0	1/60	2-4.0	MULTIPLE CKT 2	28.8/33.3	0.0	36/42	40/50
		6.0/8.0	1/60	2-4.0	MULTIPLE	28.8/33.3	0.0	36/42	40/50
	RXBH-24A30J-1	21.6/28.8	1/60	6-4.8	SINGLE	103.8/120.	4.7	135/156	140/160
	RXBH-24A30J-1 (6024S only)	7.2/9.6	1/60	2-4.8	MULTIPLE CKT 1	34.6/40.0	4.7	50/56	50/60
		7.2/9.6	1/60	2-4.8	MULTIPLE CKT 2	34.6/40.0	0.0	44/50	50/50
		7.2/9.6	1/60	2-4.8	MULTIPLE CKT 3	34.6/40.0	0.0	44/50	50/50
	RXBH-1724A07C-1	5.4/7.2	3/60	3-2.4	SINGLE	15.0/17.3	4.7	25/28	30/30
	RXBH-1724A10C-1	7.2/9.6	3/60	3-3.2	SINGLE	20.0/23.1	4.7	31/35	40/40
	RXBH-1724A15C-1	10.8/14.4	3/60	3-4.8	SINGLE	30.0/34.6	4.7	44/50	50/50
	RXBH-1724A18C-1	12.8/17.0	3/60	3/5/08	SINGLE	35.6/41.0	4.7	51/58	60/60
	RXBH-24A20C-1	14.4/19.2	3/60	6-3.2	SINGLE	40.0/46.2	4.7	56/64	60/70
	RXBH-24A20C-1	7.2/9.6	3/60	3-3.2	MULTIPLE CKT 1	20.0/23.1	4.7	31/35	40/40
		7.2/9.6	3/60	3-3.2	MULTIPLE CKT 2	20.0/23.1	0.0	25/29	30/30
	RXBH-24A25C-1	18.0/24.0	3/60	6-4.0	SINGLE	50.0/57.8	4.7	69/79	70/80
	RXBH-24A25C-1	9.0/12.0	3/60	3-4.0	MULTIPLE CKT 1	25.0/28.9	4.7	38/42	40/50
		9.0/12.0	3/60	3-4.0	MULTIPLE CKT 2	25.0/28.9	0.0	32/37	40/40
RXBH-24A30C-1	21.6/28.8	3/60	6-4.8	SINGLE	60.0/69.4	4.7	81/93	90/100	
RXBH-24A30C-1 (6024S only)	10.8/14.4	3/60	3-4.8	MULTIPLE CKT 1	30.0/34.7	4.7	44/50	50/50	
	10.8/14.4	3/60	3-4.8	MULTIPLE CKT 2	30.0/34.7	0.0	38/44	40/50	
4824S 6021S 6024S	RXBH-24A07D-1	7.2	3/60	3-2.4	SINGLE	8.7	5.6	18/18	20/20
	RXBH-24A10D-1	9.6	3/60	3-3.2	SINGLE	11.6	5.6	22/22	30/30
	RXBH-24A15D-1	14.4	3/60	3-4.8	SINGLE	17.3	5.6	29/29	30/30
	RXBH-24A18D-1	17.0	3/60	6/2/84	SINGLE	20.4	5.6	33/33	40/40
	RXBH-24A20D-1	19.2	3/60	6-3.2	SINGLE	23.2	5.6	36/36	40/40
	RXBH-24A25D-1	24.0	3/60	6-4.0	SINGLE	28.8	5.6	43/43	50/50
	RXBH-24A30D-1 (6024S only)	28.8	3/60	6-4.8	SINGLE	34.6	5.6	51/51	60/60

Electrical Wiring

Power Wiring

- Field wiring must comply with the National Electrical Code (C.E.C. in Canada) and any applicable local ordinance.
- Supply wiring must be 75°C minimum copper conductors only.
- See electrical data for product Ampacity rating and Circuit Protector requirement.

Accessories

• Combustible Floor Base RXHB-

Model Cabinet Size	Combustible Floor Base Model Number
17	RXHB-17
21	RXHB-21
24	RXHB-24

- **Jumper Bar Kit 3 Ckt. to 1 Ckt. RXBJ-A31** is used to convert single phase multiple three circuit units to a single supply circuit. Kit includes cover and screw for line side terminals.
- **Jumper Bar Kit 2 Ckt. to 1 Ckt. RXBJ-A21** is used to convert single phase multiple two circuit units to a single supply circuit. Kit includes cover and screw for line side terminals.
- **Note:** No jumper bar kit is available to convert three phase multiple two circuit units to a single supply circuit.
- **Auxiliary Horizontal Overflow Pan Accessory RXBM-**

Nominal Cooling Capacity-Tons	Auxiliary Horizontal Overflow Pan Accessory Model Number
1 1/2 - 3	RXBM-AC48
3 1/2 - 5	RXBM-AC61

Grounding

- This product must be sufficiently grounded in accordance with National Electrical Code (C.E.C. in Canada) and any applicable local ordinance.
- A grounding lug is provided.

• Auxiliary Electric Heater Kits RXBH-

Heater Kits include circuit breakers which meet UL and cUL requirements for service disconnect. See the Electric Heat Electrical Data in this specification sheet for specific Heater Kit Model numbers.

• Horizontal Adapter Kit RXHH-

This horizontal adapter kit is used to convert Upflow/Downflow only models to horizontal flow. See the following table to order proper horizontal adapter kit.

Coil Model	Horizontal Adapter Kit Model Number (Single Qty.)	Horizontal Adapter Kit Model Number (10-Pack Qty.)
2414	RXHH-A01	RXHH-A01 x 10
2417	RXHH-A02	RXHH-A02 x 10
3617/3621	RXHH-A03	RXHH-A03 x 10
3821/4821/4824	RXHH-A04	RXHH-A04 x 10
3621HT/4821MT/6021ST	RXHH-06	RXHH-06 x 10
6024	RXHH-A05	RXHH-A05 x 10

• External Filter Base RXHF-

Model Cabinet Size	Filter Size In. [mm]	Part Number*	A	B
17	16 x 20 [406 x 508]	RXHF-17	15.70	17.5
21	20 x 20 [508 x 508]	RXHF-21	19.20	21.0
24	25 x 20 [635 x 508]	RXHF-24	22.70	25.5

*Accommodates 1" or 2" filter

[] Designates Metric Conversions

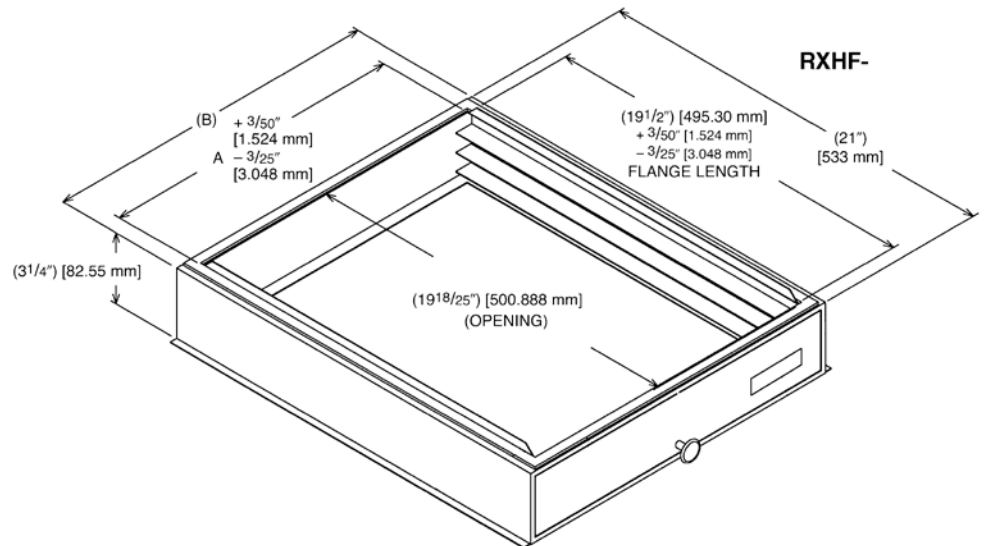
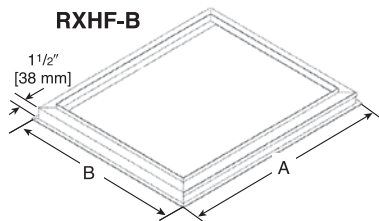



The new degree of comfort.®

Endeavor™ Line Air Handlers



RH2VZ

Constant CFM Motor

2-Stage Airflow

Thermal Expansion Valve (TXV)

Efficiencies: 13.4 to 14.3 SEER2

Table of Contents

Features & Benefits	3
Model Number Identification	4
Dimensional Data	5-6
Airflow Directional Data	7
Airflow Performance Data	8
Electrical Data	9-18
Limited Warranty	20

Features and Benefits

- **Constant CFM Motor:**
 - When paired with EcoNet® Smart Thermostat, gradually auto-adjusts from low capacity to 100% of capacity to meet comfort requirements—allowing for ultimate humidity control, quieter sounds levels and year-round energy savings
 - When paired with 24V two-stage thermostat, air handler runs in 2 speeds to match airflow with outdoor unit
- **Quieter Operation¹:** Provided by two-stage operation and truly variable speed airflow technology and sturdy cabinet construction with 1.0 inch of foil faced insulation for quieter sound characteristics
- **PlusOne® Diagnostics:** With the Rheem Contractor & EcoNet® Apps, built-in EcoNet® & Bluetooth² technology makes monitoring, troubleshooting and repairing the product easier than ever before
- **Dip Switch Free Installation Commissioning via Bluetooth Technology:** Seamless final install step without DIP switch configuration using the Rheem Contractor App
- **EcoNet® Enabled Air Handler³:**
 - The latest in sensor technology and the EcoNet® monitoring system provides a new level of protection, control and energy savings
 - Allows on-the-go control and receipt of system alerts by the homeowner via the EcoNet® Smart Thermostat and EcoNet® App⁴
- **Aluminum Indoor Coil Design:** Are constructed of aluminum fins bonded to internally grooved aluminum tubing and are more corrosion resistant
- **Versatile 4-Way Convertible Compact Design:** Allows for upflow, downflow, horizontal left and horizontal right applications, even in the smallest of spaces
- **Rugged Steel, Compact Cabinet Construction:** Designed for added strength and versatility
- **Field-installed Auxiliary Heater Kits:** Provide exact heat for indoor comfort and include circuit breakers which meet UL and cUL requirements for service disconnect
- **Less than 2% Cabinet Air Leakage at 1-inch H₂O:** When tested in accordance with ASHRAE Standard 193

¹ Based on manufacturer's air handler offering, and the product's airflow stages, motor type and cabinet insulation. Sound levels are also dependent on air handler location and installation.

² The Bluetooth® word mark and logos are registered trademarks owned by Bluetooth SIG, Inc. and any use of such marks by Rheem® is under license. Other trademarks and trade names are those of their respective owners.

³ Fully communicating systems coming soon. Non-communicating system EcoNet® benefits include demand response connection and unit monitoring.

⁴ Wifi broadband internet connection required. Download the EcoNet® App from the App Store® or Google Play® to set up your EcoNet® Smart Thermostat. Receipt of notifications depend on home WiFi set up. Amazon, Alex and all related logos are trademarks of Amazon.com, Inc. or its affiliates.

Air Handlers

<u>R</u>	<u>H</u>	<u>2</u>	<u>V</u>	<u>Z</u>	<u>24</u>	<u>17</u>	<u>S</u>	<u>T</u>	<u>A</u>	<u>N</u>	<u>N</u>	<u>J</u>
Brand	Stages Of Airflow	Motor Type	Refrigerant	Capacity	Width	Efficiency	Metering	Major Series	Controls	Coil Series	Voltage	
R - Rheem	H - Air Handler	2 - 2-Stage	C - Constant CFM	Z - R-410A	24 - 24,000 [7.03 kW] 36 - 36,000 [10.55 kW] 48 - 48,000 [14.07 kW] 60 - 60,000 [17.58 kW]	17 - 17.5" 21 - 21" 24 - 24.5"	S - Standard M - Mid	T - TXV	A - 1st Design	N - Non-Communicating ¹	A - A Coil N - N Coil	J - 208-240/1/60

[] Designates Metric Conversions

Available Models
RH2VZ2417STANNJ
RH2VZ3617STANNJ
RH2VZ3621STANNJ
RH2VZ3621MTANAJ
RH2VZ3621MTANNJ
RH2VZ4821STANNJ
RH2VZ4821STANAJ
RH2VZ4824STANNJ
RH2VZ6021STANAJ
RH2VZ6024STANNJ

Standard Equipment
EcoNet Air Handler Control Board
Quiet efficient ECM Motor technology
Selectable continuous fan "on" option
Compact unit design
Attractive pre-painted cabinet exterior
Rugged steel cabinet construction
1.0" foil faced insulation mechanically retained in blower compartment
Four leg rubber insulated motor mount
Blower housing with integrated controls, motor and blower slide out design
Compact indoor coil design
Coils constructed of aluminum fins bonded to internally grooved aluminum
Coils have copper sweat refrigerant connections
Coils utilize chatleff metering device connections
Molded polymer corrosion resistant condensate drain pan
Supply duct flanges
Side or top cabinet provisions for electrical connections
High voltage wiring connection point inside cabinet
Low voltage wiring connection point on outside of cabinet
Concentric knockouts for power connections
Front refrigerant and drain connections

¹ Fully communicating systems coming soon. Non-communicating system EcoNet® benefits include demand response connection and unit monitoring.

Unit Dimensions

ELECTRICAL CONNECTIONS
MAY EXIT TOP OR EITHER SIDE
HIGH VOLTAGE CONNECTION 7/8" [22.2 mm],
1 3/32" [27.8 mm], 1 3/16" [50 mm] DIA. KNOCKOUTS.

LOW VOLTAGE CONNECTION
5/8" [15.9 mm] AND 7/8" [22.2 mm] KNOCKOUT

AUXILIARY DRAIN CONNECTION
3/4" [19.1 mm] FEMALE PIPE THREAD (NPT)
HORIZONTAL APPLICATION ONLY

PRIMARY DRAIN CONNECTION
3/4" [19.1 mm] FEMALE PIPE THREAD (NPT)

AUXILIARY DRAIN CONNECTION
3/4" [19.1 mm] FEMALE PIPE THREAD (NPT)
UPFLOW/DOWNFLOW APPLICATION ONLY

LIQUID LINE CONNECTION
COPPER (SWEAT)

VAPOR LINE CONNECTION
COPPER (SWEAT)

SUPPLY AIR ↑

NOTE: 24" CLEARANCE REQUIRED IN FRONT OF
UNIT FOR FILTER AND COIL MAINTENANCE.

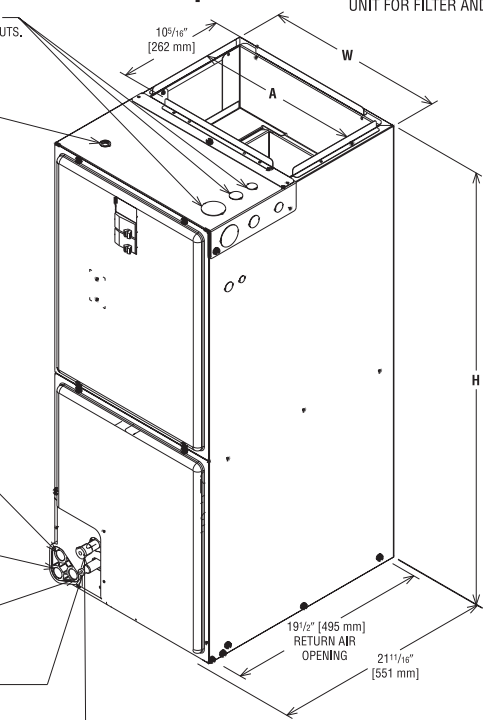

UPFLOW UNIT SHOWN:
UNIT MAY BE INSTALLED UPFLOW, DOWNFLOW,
HORIZONTAL RIGHT OR LEFT AIR SUPPLY.

Return Air Opening Dimensions

Model Cabinet Size	Return Air Opening Width (Inches)	Return Air Opening Depth/Length (Inches)
17	15 7/8	19 3/4
21	19 3/8	19 3/4
24	22 7/8	19 3/4

HORIZONTAL ADAPTER KIT

VAPOR LINE CONNECTION

AUXILIARY HORIZONTAL DRAIN CONNECTION

PRIMARY DRAIN CONNECTION

AUXILIARY UPFLOW/DOWNFLOW DRAIN CONNECTION

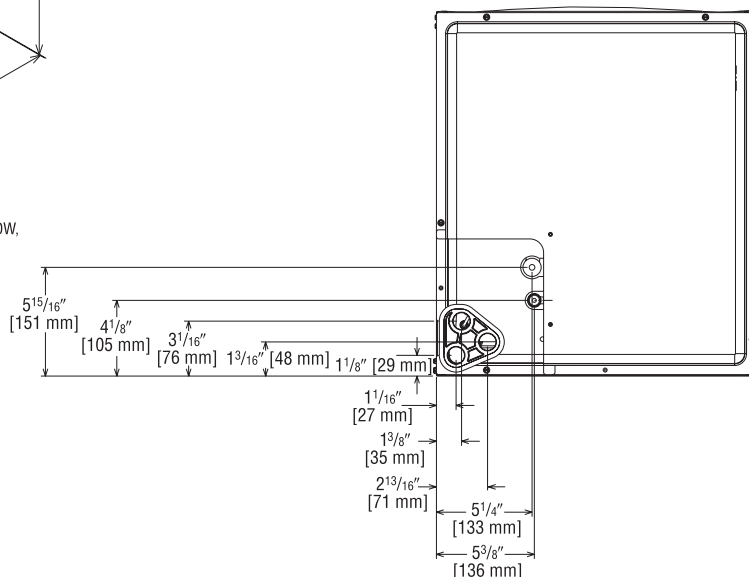
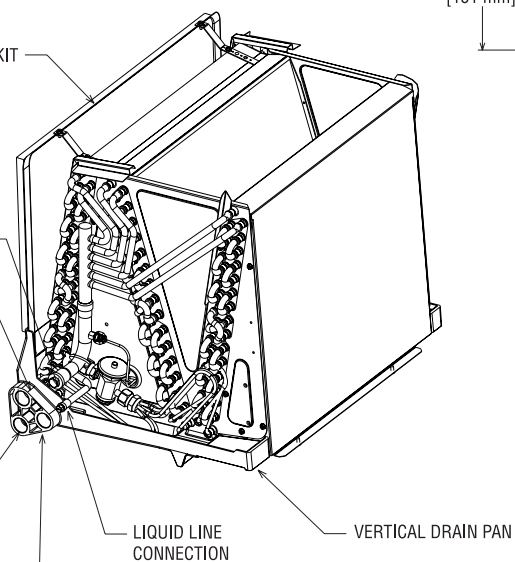

UPFLOW UNIT SHOWN:
UNIT MAY BE INSTALLED UPFLOW,
DOWNFLOW, HORIZONTAL RIGHT
OR LEFT AIR SUPPLY.

[] Designates Metric Conversions
() Designates Unit with Double Coil Cabinet

Unit Dimensions & Weights

Model Family	Model Size RH2VZ	Refrigerant Connections Sweat (In.) [mm] ID		Unit Width "W" In. [mm]	Unit Height "H" In. [mm]	Supply Duct "A" In. [mm]	Unit Weight/Shipping Weight (Lbs.) [kg]
		Liquid	Vapor				Unit With Coil (Max. KW)
RH2VZ	2417STANN	3/8 [9.53]	3/4 [19.05]	17 1/2 [445]	42 1/2 [1080]	16 [406]	91/105 [41/48]
	3617STANN	3/8 [9.53]	3/4 [19.05]	17 1/2 [445]	42 1/2 [1080]	16 [406]	98/112 [44/51]
	3621STANN	3/8 [9.53]	3/4 [19.05]	21 [533]	42 1/2 [1080]	19 1/2 [495]	103/118 [47/54]
	3621MTANN	3/8 [9.53]	7/8 [22.23]	21 [533]	50 1/2 [1282]	19 1/2 [495]	126/142 [57/64]
	3621MTANA	3/8 [9.53]	7/8 [22.23]	21 [533]	57 [1448]	19 1/2 [495]	138/150 [63/68]
	4821STANN	3/8 [9.53]	7/8 [22.23]	21 [533]	50 1/2 [1282]	19 1/2 [495]	128/144 [56/65]
	4821STANA	3/8 [9.53]	7/8 [22.23]	21 [533]	57 [1448]	19 1/2 [495]	140/152 [64/69]
	4824STANN	3/8 [9.53]	7/8 [22.23]	24 1/2 [622]	55 1/2 [1410]	23 [584]	142/160 [64/73]
	6021STANA	3/8 [9.53]	7/8 [22.23]	21 [533]	57 [1448]	19 1/2 [495]	140/152 [64/69]
6024STANN	3/8 [9.53]	7/8 [22.23]	24 1/2 [622]	55 1/2 [1410]	23 [584]	159/176 [72/80]	

*Maximum dehumidification airflow.

[] Designates Metric Conversions

Airflow Directional Data

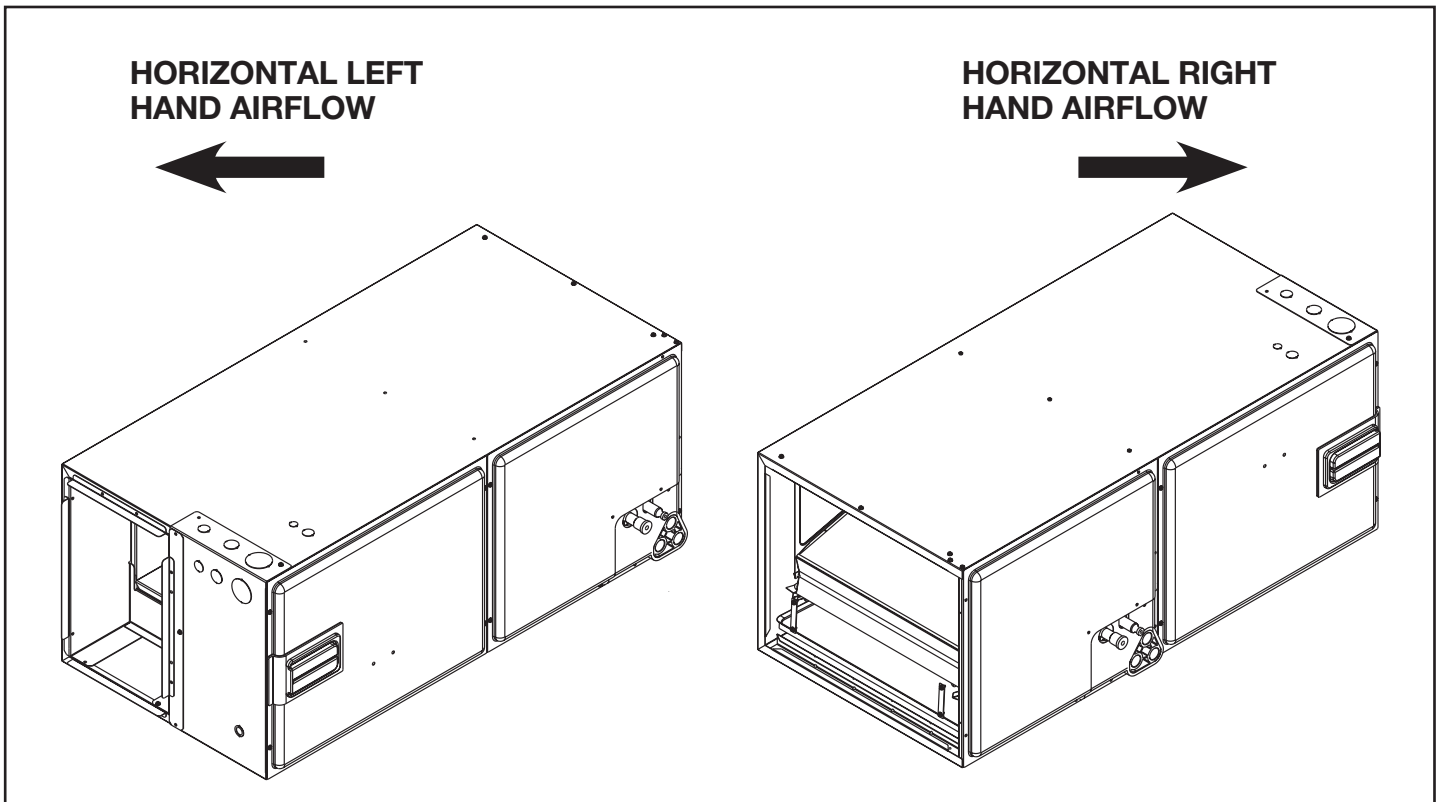
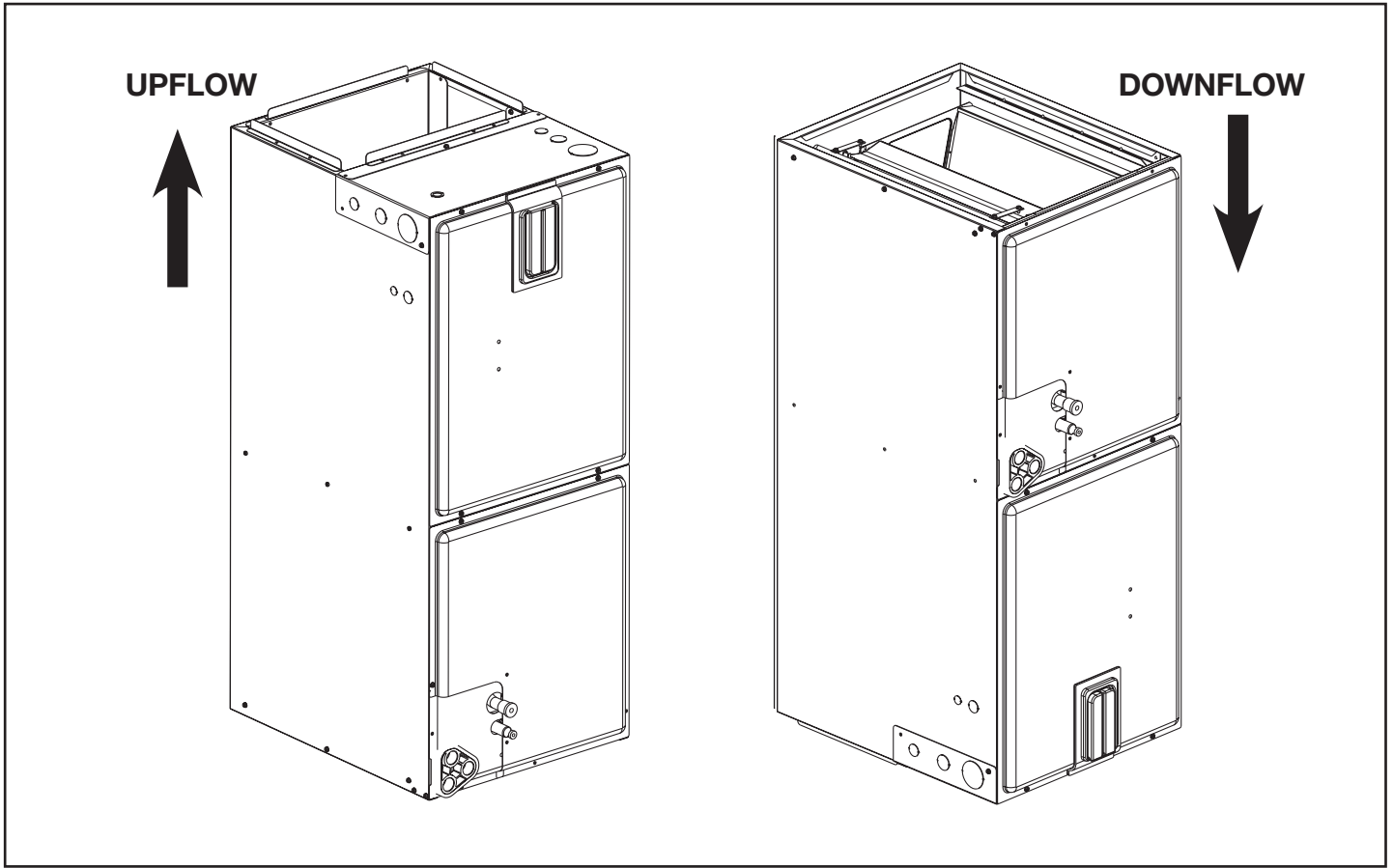

Airflow Performance

Airflow performance data is based on cooling performance with a coil and no filter in place. Select performance table for appropriate unit size, voltage and number of electric heaters to be used. Make sure external static applied to unit allows operation within the minimum and maximum limits shown in

table below for both cooling and electric heat operation. For optimum blower performance, operate the unit in the .3 [8 mm] to .7 inches [18 mm] W.C. external static range. Units with coils should be applied with a minimum of .1 inch [3 mm] W.C. external static range.

Airflow Performance Data RH2V

Rated Airflow for RH2VZ Air Handlers + RA13/RA14 Condensing Units & RP14/RP15 Heat Pumps					
Air Handler Model	Outdoor Model	RH2VZ Airflow (EcoNet®)*			
		Cooling Mode CFM [L/s]		Heating Mode CFM [L/s]	
		Minimum	Maximum	Minimum	Maximum
RH2VZ2417STANN	RA13NZ18/RA13NZ24	580 [274]	767 [362]	—	—
	RA14AZ18/RA14AZ24			—	—
	RP14AZ18/RP14AZ24			580 [274]	767 [362]
	RP15AZ18/RP15AZ24			—	—
RH2VZ3617STANN	RA13NZ30/RA13NZ36	727 [343]	1069 [505]	—	—
	RA14AZ30/RA14AZ36			—	—
	RP14AZ30/RP14AZ36			727 [343]	1069 [505]
	RP15AZ30/RP15AZ36			—	—
RH2VZ3621STANN	RA13NZ30/RA13NZ36	727 [343]	1069 [505]	—	—
	RA14AZ30/RA14AZ36			—	—
	RP14AZ30/RP14AZ36			727 [343]	1069 [505]
	RP15AZ30/RP15AZ36			—	—
RH2VZ3621MTANN	RA13NZ30/RA13NZ36	727 [343]	1069 [505]	—	—
	RA14AZ30/RA14AZ36			—	—
RH2VZ3621MTANA	RA13NZ30/RA13NZ36	727 [343]	1069 [505]	—	—
	RA14AZ30/RA14AZ36			—	—
RH2VZ4821STANN	RA13NZ42/RA13NZ48	1024 [483]	1478 [698]	—	—
	RA14AZ42/RA14AZ48			—	—
	RP14AZ42/RP14AZ48			1024 [483]	1478 [698]
	RP15AZ42/RP15AZ48			—	—
RH2VZ4821STANA	RA13NZ42/RA13NZ48	1024 [483]	1478 [698]	—	—
	RA14AZ42/RA14AZ48			—	—
RH2VZ4824STANN	RA13NZ42/RA13NZ48	1024 [483]	1478 [698]	—	—
	RA14AZ42/RA14AZ48			—	—
	RP14AZ42/RP14AZ48			1024 [483]	1478 [698]
	RP15AZ42/RP15AZ48			—	—
RH2VZ6021STANA	RA13NZ60/RA13NZ60	1140 [538]	1857 [876]	—	—
RH2VZ6024STANN	RA13NZ60/RA13NZ60	1140 [538]	1857 [876]	—	—
	RP14AZ60/RP15AZ60			1140 [538]	1857 [876]

*When using an EcoNet® Control Center, the air handler will deliver 375 CFM/ton.

[] Designates Metric Conversions

Electrical Data – Blower Motor Only – No Electric Heat RH2VZ

Model Family	Model Size	Voltage	Phase	Hertz	HP [W]	RPM	Circuit Amps.	Minimum Circuit Ampacity	Maximum Circuit Protector
RH2VZ	2417STANN	208/240	1	60	1/3	300-1300	2.8	4	15
	3617STANN		1		1/2		4.6	6	15
	3621STANN		1		1/3		2.7	4	15
	3621MTANN		1		1/2		3.9	5	15
	3621MTANA		1		1/2		3.8	5	15
	4821STANN		1		3/4		5.4	7	15
	4821STANA		1		3/4		5.7	8	15
	4824STANN		1		3/4		5.1	7	15
	6021STANA		1		3/4		5.7	8	15
	6024STANN		1		3/4		5.2	7	15

*Blower motors are all single-phase motors

[] Designates Metric Conversions

Electrical Data – With Electric Heat RH2VZ

Installation of the U.L. Listed original equipment manufacturer provided heater kits listed in the table below is recommended for all auxiliary heating requirements.

Air Handler Model	Heater Model No.	Heater kW (208/240V)	PH/HZ	No. Elements kW Per	Circuit Type	Heater Circuit Amps	Tested Blower Motor Amps	Minimum Circuit Ampacity	Maximum Overcurrent Protection
RH2VZ2417STANNJ	RXBH-1724?03J-B	2.3/3.0	1/60	1-3.0	SINGLE	11.1/12.5	2.8	18/20	20/20
	RXBH-1724?05J-B	3.6/4.8	1/60	1-4.8	SINGLE	17.4/20	2.8	26/29	30/30
	RXBH-1724?07J-B	5.4/7.2	1/60	2-3.6	SINGLE	26/30	2.8	36/41	40/45
	RXBH-1724?10J-B	7.2/9.6	1/60	2-4.8	SINGLE	34.7/40	2.8	47/54	50/60
	RXBH-1724A13J-B	9.4/12.5	1/60	3-4.17	SINGLE	45.2/52.1	2.8	60/69	60/70
		3.1/4.2	1/60	1-4.17	MULTIPLE CKT 1	15/17.5	2.8	23/26	25/30
		6.3/8.3	1/60	2-4.17	MULTIPLE CKT 2	30.3/34.6	0	38/44	40/45
	RXBH-17A05C-B	3.6/4.8	3/60	1-4.8	SINGLE	10/11.6	2.8	16/18	20/20
	RXBH-24A05C-B	3.6/4.8	3/60	1-4.8	SINGLE	10/11.6	2.8	16/18	20/20
	RXBH-1724B05C-B	3.6/4.8	3/60	1-4.8	SINGLE	10/11.6	2.8	16/18	20/20
	RXBH-1724A07C-B	5.4/7.2	3/60	2-3.6	SINGLE	15/17.4	2.8	23/26	25/30
	RXBH-1724A10C-B	7.2/9.6	3/60	2-4.8	SINGLE	20/23.1	2.8	29/33	30/35
RXBH-1724A13C-B	9.4/12.5	3/60	3-4.17	SINGLE	26.1/30.1	2.8	37/42	40/45	
RH2VZ3617STANNJ	RXBH-1724?03J-B	2.3/3.0	1/60	1-3.0	SINGLE	11.1/12.5	4.6	20/22	20/25
	RXBH-1724?05J-B	3.6/4.8	1/60	1-4.8	SINGLE	17.4/20	4.6	28/31	30/35
	RXBH-1724?07J-B	5.4/7.2	1/60	2-3.6	SINGLE	26/30	4.6	39/44	40/45
	RXBH-1724?10J-B	7.2/9.6	1/60	2-4.8	SINGLE	34.7/40	4.6	50/56	50/60
	RXBH-1724A13J-B	9.4/12.5	1/60	3-4.17	SINGLE	45.2/52.1	4.6	63/71	70/80
		3.1/4.2	1/60	1-4.17	MULTIPLE CKT 1	15/17.5	4.6	25/28	25/30
		6.3/8.3	1/60	2-4.17	MULTIPLE CKT 2	30.3/34.6	0	38/44	40/45
	RXBH-1724A15J-B	10.8/14.4	1/60	3-4.8	SINGLE	52/60	4.6	71/81	80/90
	RXBH-1724A15J-B	3.6/4.8	1/60	1-4.8	MULTIPLE CKT 1	17.4/20	4.6	28/31	30/35
		7.2/9.6	1/60	2-4.8	MULTIPLE CKT 2	34.7/40	0	44/50	45/50
	RXBH-1724A18J-B	12.8/17.0	1/60	3-5.68	SINGLE	61.6/70.9	4.6	83/95	90/100
	RXBJ-1724A18J-B	4.3/5.7	1/60	1-5.68	MULTIPLE CKT 1	20.7/23.8	4.6	32/36	35/40
		8.5/11.3	1/60	2-5.68	MULTIPLE CKT 2	40.9/47.1	0	52/59	60/60
	RXBH-17A05C-B	3.6/4.8	3/60	1-4.8	SINGLE	10/11.6	4.6	19/21	20/25
	RXBH-24A05C-B	3.6/4.8	3/60	1-4.8	SINGLE	10/11.6	4.6	19/21	20/25
	RXBH-1724B05C-B	3.6/4.8	3/60	1-4.8	SINGLE	10/11.6	4.6	19/21	20/25
	RXBH-1724A07C-B	5.4/7.2	3/60	2-3.6	SINGLE	15/17.4	4.6	25/28	25/30
	RXBH-1724A10C-B	7.2/9.6	3/60	2-4.8	SINGLE	20/23.1	4.6	31/35	35/35
	RXBH-1724A13C-B	9.4/12.5	3/60	3-4.17	SINGLE	26.1/30.1	4.6	39/44	40/45
	RXBH-1724A15C-B	10.8/14.4	3/60	3-4.8	SINGLE	30/34.7	4.6	44/50	45/50
RXBH-1724A18C-B	12.8/17.0	3/60	3-5.68	SINGLE	35.6/40.9	4.6	51/57	60/60	

? = A/B/C Heater Connection Types

A = Breaker

B = Terminal Block

C = Pullout Disconnect

Electrical Data – With Electric Heat RH2VZ (Con't.)

Installation of the U.L. Listed original equipment manufacturer provided heater kits listed in the table below is recommended for all auxiliary heating requirements.

Air Handler Model	Heater Model No.	Heater kW (208/240V)	PH/HZ	No. Elements kW Per	Circuit Type	Heater Circuit Amps	Tested Blower Motor Amps	Minimum Circuit Ampacity	Maximum Overcurrent Protection
RH2VZ3621STANNJ	RXBH-1724?03J-B	2.3/3.0	1-3.0	1-3.0	SINGLE	11.1/12.5	2.7	18/19	20/20
	RXBH-1724?05J-B	3.6/4.8	1-4.8	1-4.8	SINGLE	17.4/20	2.7	26/29	30/30
	RXBH-1724?07J-B	5.4/7.2	2-3.6	2-3.6	SINGLE	26/30	2.7	36/41	40/45
	RXBH-1724?10J-B	7.2/9.6	2-4.8	2-4.8	SINGLE	34.7/40	2.7	47/54	50/60
	RXBH-1724A13J-B	9.4/12.5	3-4.17	3-4.17	SINGLE	45.2/52.1	2.7	60/69	60/70
		3.1/4.2	1-4.17	1-4.17	MULTIPLE CKT 1	15/17.5	2.7	23/26	25/30
		6.3/8.3	2-4.17	2-4.17	MULTIPLE CKT 2	30.3/34.6	0	38/44	40/45
	RXBH-1724A15J-B	10.8/14.4	3-4.8	3-4.8	SINGLE	52/60	2.7	69/79	70/80
	RXBH-1724A15J-B	3.6/4.8	1-4.8	1-4.8	MULTIPLE CKT 1	17.4/20	2.7	26/29	30/30
		7.2/9.6	2-4.8	2-4.8	MULTIPLE CKT 2	34.7/40	0	44/50	45/50
	RXBH-1724A18J-B	12.8/17.0	3-5.68	3-5.68	SINGLE	61.6/70.9	2.7	81/92	90/100
	RXBJ-1724A18J-B	4.3/5.7	1-5.68	1-5.68	MULTIPLE CKT 1	20.7/23.8	2.7	30/34	30/35
		8.5/11.3	2-5.68	2-5.68	MULTIPLE CKT 2	40.9/47.1	0	52/59	60/60
	RXBH-17A05C-B	3.6/4.8	3/60	1-4.8	SINGLE	10/11.6	2.7	16/18	20/20
	RXBH-24A05C-B	3.6/4.8	3/60	1-4.8	SINGLE	10/11.6	2.7	16/18	20/20
	RXBH-1724B05C-B	3.6/4.8	3/60	1-4.8	SINGLE	10/11.6	2.7	16/18	20/20
	RXBH-1724A07C-B	5.4/7.2	3/60	2-3.6	SINGLE	15/17.4	2.7	23/26	25/30
	RXBH-1724A10C-B	7.2/9.6	3/60	2-4.8	SINGLE	20/23.1	2.7	29/33	30/35
	RXBH-1724A13C-B	9.4/12.5	3/60	3-4.17	SINGLE	26.1/30.1	2.7	36/41	40/45
	RXBH-1724A15C-B	10.8/14.4	3/60	3-4.8	SINGLE	30/34.7	2.7	41/47	45/50
RXBH-1724A18C-B	12.8/17.0	3/60	3-5.68	SINGLE	35.6/40.9	2.7	48/55	50/60	
RH2VZ3621MTANNJ	RXBH-1724?03J-B	2.3/3.0	1/60	1-3.0	SINGLE	11.1/12.5	3.9	19/21	20/25
	RXBH-1724?05J-B	3.6/4.8	1/60	1-4.8	SINGLE	17.4/20	3.9	27/30	30/30
	RXBH-1724?07J-B	5.4/7.2	1/60	2-3.6	SINGLE	26/30	3.9	38/43	40/45
	RXBH-1724?10J-B	7.2/9.6	1/60	2-4.8	SINGLE	34.7/40	3.9	49/55	50/60
	RXBH-1724A13J-B	9.4/12.5	1/60	3-4.17	SINGLE	45.2/52.1	3.9	62/70	70/70
		3.1/4.2	1/60	1-4.17	MULTIPLE CKT 1	15/17.5	3.9	24/27	25/30
		6.3/8.3	1/60	2-4.17	MULTIPLE CKT 2	30.3/34.6	0	38/44	40/45
	RXBH-1724A15J-B	10.8/14.4	1/60	3-4.8	SINGLE	52/60	3.9	70/80	70/80
	RXBH-1724A15J-B	3.6/4.8	1/60	1-4.8	MULTIPLE CKT 1	17.4/20	3.9	27/30	30/30
		7.2/9.6	1/60	2-4.8	MULTIPLE CKT 2	34.7/40	0	44/50	45/50
	RXBH-1724A18J-B	12.8/17.0	1/60	3-5.68	SINGLE	61.6/70.9	3.9	82/94	90/100
	RXBJ-1724A18J-B	4.3/5.7	1/60	1-5.68	MULTIPLE CKT 1	20.7/23.8	3.9	31/35	35/35
		8.5/11.3	1/60	2-5.68	MULTIPLE CKT 2	40.9/47.1	0	52/59	60/60
	RXBH-17A05C-B	3.6/4.8	3/60	1-4.8	SINGLE	10/11.6	3.9	18/20	20/20
	RXBH-24A05C-B	3.6/4.8	3/60	1-4.8	SINGLE	10/11.6	3.9	18/20	20/20
	RXBH-1724B05C-B	3.6/4.8	3/60	1-4.8	SINGLE	10/11.6	3.9	18/20	20/20
	RXBH-1724A07C-B	5.4/7.2	3/60	2-3.6	SINGLE	15/17.4	3.9	24/27	25/30
	RXBH-1724A10C-B	7.2/9.6	3/60	2-4.8	SINGLE	20/23.1	3.9	30/34	30/35
	RXBH-1724A13C-B	9.4/12.5	3/60	3-4.17	SINGLE	26.1/30.1	3.9	38/43	40/45
	RXBH-1724A15C-B	10.8/14.4	3/60	3-4.8	SINGLE	30/34.7	3.9	43/49	45/50
RXBH-1724A18C-B	12.8/17.0	3/60	3-5.68	SINGLE	35.6/40.9	3.9	50/56	50/60	

? = A/B/C Heater Connection Types

A = Breaker

B = Terminal Block

C = Pullout Disconnect

Electrical Data – With Electric Heat RH2VZ (Con't.)

Installation of the U.L. Listed original equipment manufacturer provided heater kits listed in the table below is recommended for all auxiliary heating requirements.

Air Handler Model	Heater Model No.	Heater kW (208/240V)	PH/HZ	No. Elements kW Per	Circuit Type	Heater Circuit Amps	Tested Blower Motor Amps	Minimum Circuit Ampacity	Maximum Overcurrent Protection
RH2VZ3621MTANAJ	RXBH-1724?03J-B	2.3/3.0	1/60	1-3.0	SINGLE	11.1/12.5	3.8	19/21	20/25
	RXBH-1724?05J-B	3.6/4.8	1/60	1-4.8	SINGLE	17.4/20	3.8	27/30	30/30
	RXBH-1724?07J-B	5.4/7.2	1/60	2-3.6	SINGLE	26/30	3.8	38/43	40/45
	RXBH-1724?10J-B	7.2/9.6	1/60	2-4.8	SINGLE	34.7/40	3.8	49/55	50/60
	RXBH-1724A13J-B	9.4/12.5	1/60	3-4.17	SINGLE	45.2/52.1	3.8	62/70	70/70
		3.1/4.2	1/60	1-4.17	MULTIPLE CKT 1	15/17.5	3.8	24/27	25/30
	RXBH-1724A15J-B	6.3/8.3	1/60	2-4.17	MULTIPLE CKT 2	30.3/34.6	0	38/44	40/45
		10.8/14.4	1/60	3-4.8	SINGLE	52/60	3.8	70/80	70/80
	RXBH-1724A15J-B	3.6/4.8	1/60	1-4.8	MULTIPLE CKT 1	17.4/20	3.8	27/30	30/30
		7.2/9.6	1/60	2-4.8	MULTIPLE CKT 2	34.7/40	0	44/50	45/50
	RXBH-1724A18J-B	12.8/17.0	1/60	3-5.68	SINGLE	61.6/70.9	3.8	82/94	90/100
	RXBJ-1724A18J-B	4.3/5.7	1/60	1-5.68	MULTIPLE CKT 1	20.7/23.8	3.8	31/35	35/35
		8.5/11.3	1/60	2-5.68	MULTIPLE CKT 2	40.9/47.1	0	52/59	60/60
	RXBH-17A05C-B	3.6/4.8	3/60	1-4.8	SINGLE	10/11.6	3.8	18/20	20/20
	RXBH-24A05C-B	3.6/4.8	3/60	1-4.8	SINGLE	10/11.6	3.8	18/20	20/20
	RXBH-1724B05C-B	3.6/4.8	3/60	1-4.8	SINGLE	10/11.6	3.8	18/20	20/20
	RXBH-1724A07C-B	5.4/7.2	3/60	2-3.6	SINGLE	15/17.4	3.8	24/27	25/30
	RXBH-1724A10C-B	7.2/9.6	3/60	2-4.8	SINGLE	20/23.1	3.8	30/34	30/35
	RXBH-1724A13C-B	9.4/12.5	3/60	3-4.17	SINGLE	26.1/30.1	3.8	38/43	40/45
	RXBH-1724A15C-B	10.8/14.4	3/60	3-4.8	SINGLE	30/34.7	3.8	43/49	45/50
RXBH-1724A18C-B	12.8/17.0	3/60	3-5.68	SINGLE	35.6/40.9	3.8	50/56	50/60	
RH2VZ4821STANNJ	RXBH-1724?03J-B	2.3/3.0	1/60	1-3.0	SINGLE	11.1/12.5	5.4	21/23	25/25
	RXBH-1724?05J-B	3.6/4.8	1/60	1-4.8	SINGLE	17.4/20	5.4	29/32	30/35
	RXBH-1724?07J-B	5.4/7.2	1/60	2-3.6	SINGLE	26/30	5.4	40/45	40/45
	RXBH-1724?10J-B	7.2/9.6	1/60	2-4.8	SINGLE	34.7/40	5.4	51/57	60/60
	RXBH-1724A13J-B	9.4/12.5	1/60	3-4.17	SINGLE	45.2/52.1	5.4	64/72	70/80
	RXBH-1724A13J-B	3.1/4.2	1/60	1-4.17	MULTIPLE CKT 1	15/17.5	5.4	26/29	30/30
		6.3/8.3	1/60	2-4.17	MULTIPLE CKT 2	30.3/34.6	0	38/44	40/45
	RXBH-1724A15J-B	10.8/14.4	1/60	3-4.8	SINGLE	52/60	5.4	72/82	80/90
	RXBH-1724A15J-B	3.6/4.8	1/60	1-4.8	MULTIPLE CKT 1	17.4/20	5.4	29/32	30/35
		7.2/9.6	1/60	2-4.8	MULTIPLE CKT 2	34.7/40	0	44/50	45/50
	RXBH-1724A18J-B	12.8/17.0	1/60	3-5.68	SINGLE	61.6/70.9	5.4	84/96	90/100
	RXBJ-1724A18J-B	4.3/5.7	1/60	1-5.68	MULTIPLE CKT 1	20.7/23.8	5.4	33/37	35/40
8.5/11.3		1/60	2-5.68	MULTIPLE CKT 2	40.9/47.1	0	52/59	60/60	

? = A/B/C Heater Connection Types
A = Breaker
B = Terminal Block
C = Pullout Disconnect

Electrical Data – With Electric Heat RH2VZ (Con't.)

Installation of the U.L. Listed original equipment manufacturer provided heater kits listed in the table below is recommended for all auxiliary heating requirements.

Air Handler Model	Heater Model No.	Heater kW (208/240V)	PH/HZ	No. Elements kW Per	Circuit Type	Heater Circuit Amps	Tested Blower Motor Amps	Minimum Circuit Ampacity	Maximum Overcurrent Protection
RH2VZ4821STANNJ	RXBH-24A20J-B	14.4/19.2	1/60	4-4.8	SINGLE	69.3/80	5.4	94/107	100/110
	RXBH-1724A20J-B	7.2/9.6	1/60	2-4.8	MULTIPLE CKT 1	34.7/40	5.4	51/57	60/60
		7.2/9.6	1/60	2-4.8	MULTIPLE CKT 2	34.7/40	0	44/50	45/50
	RXBH-24A25J-B	18.0/24.0	1/60	6-4.0	SINGLE	86.6/100	5.4	115/132	125/150
		6.0/8.0	1/60	2-4.0	MULTIPLE CKT 1	28.9/33.4	5.4	43/49	45/50
		6.0/8.0	1/60	2-4.0	MULTIPLE CKT 2	28.9/33.4	0	37/42	40/45
	RXBH-24A30J-B	6.0/8.0	1/60	2-4.0	MULTIPLE CKT 3	28.9/33.4	0	37/42	40/45
		21.6/28.8	1/60	6-4.8	SINGLE	103.9/120	5.4	137/157	150/175
		7.2/9.6	1/60	2-4.8	MULTIPLE CKT 1	34.7/40	5.4	51/57	60/60
	RXBH-17A05C-B	7.2/9.6	1/60	2-4.8	MULTIPLE CKT 2	34.7/40	0	44/50	45/50
		7.2/9.6	1/60	2-4.8	MULTIPLE CKT 3	34.7/40	0	44/50	45/50
		3.6/4.8	3/60	1-4.8	SINGLE	10/11.6	5.4	20/22	20/25
	RXBH-24A05C-B	3.6/4.8	3/60	1-4.8	SINGLE	10/11.6	5.4	20/22	20/25
	RXBH-1724B05C-B	3.6/4.8	3/60	1-4.8	SINGLE	10/11.6	5.4	20/22	20/25
	RXBH-1724A07C-B	5.4/7.2	3/60	2-3.6	SINGLE	15/17.4	5.4	26/29	30/30
	RXBH-1724A10C-B	7.2/9.6	3/60	2-4.8	SINGLE	20/23.1	5.4	32/36	35/40
	RXBH-1724A13C-B	9.4/12.5	3/60	3-4.17	SINGLE	26.1/30.1	5.4	40/45	40/45
	RXBH-1724A15C-B	10.8/14.4	3/60	3-4.8	SINGLE	30/34.7	5.4	45/51	45/60
	RXBH-1724A18C-B	12.8/17.0	3/60	3-5.68	SINGLE	35.6/40.9	5.4	52/58	60/60
	RXBH-24A20C-B	14.4/19.2	3/60	4-4.8	SINGLE	40/46.2	5.4	57/65	60/70
	RXBH-1724A20J-B	7.2/9.6	3/60	2-4.8	MULTIPLE CKT 1	20/23.1	5.4	32/36	35/40
		7.2/9.6	3/60	2-4.8	MULTIPLE CKT 2	20/23.1	0	25/29	25/30
	RXBH-24A25C-B	18.0/24.0	3/60	6-4.0	SINGLE	50/57.7	5.4	70/79	70/80
	RXBH-1724A20J-B	9.0/12.0	3/60	3-4.0	MULTIPLE CKT 1	25/28.9	5.4	38/43	40/45
		9.0/12.0	3/60	3-4.0	MULTIPLE CKT 2	25/28.9	0	32/37	35/40
	RXBH-24A30C-B	21.6/28.8	3/60	6-4.8	SINGLE	60/69.3	5.4	82/94	90/100
	RXBH-1724A20J-B	10.8/14.4	3/60	3-4.8	MULTIPLE CKT 1	30/34.7	5.4	45/51	45/60
10.8/14.4		3/60	3-4.8	MULTIPLE CKT 2	30/34.7	0	38/44	40/45	
RH2VZ4821STANAJ	RXBH-1724?03J-B	2.3/3.0	1/60	1-3.0	SINGLE	11.1/12.5	5.7	21/23	25/25
	RXBH-1724?05J-B	3.6/4.8	1/60	1-4.8	SINGLE	17.4/20	5.7	29/33	30/35
	RXBH-1724?07J-B	5.4/7.2	1/60	2-3.6	SINGLE	26/30	5.7	40/45	40/45
	RXBH-1724?10J-B	7.2/9.6	1/60	2-4.8	SINGLE	34.7/40	5.7	51/58	60/60
	RXBH-1724A13J-B	9.4/12.5	1/60	3-4.17	SINGLE	45.2/52.1	5.7	64/73	70/80
		3.1/4.2	1/60	1-4.17	MULTIPLE CKT 1	15/17.5	5.7	26/29	30/30
		6.3/8.3	1/60	2-4.17	MULTIPLE CKT 2	30.3/34.6	0	38/44	40/45

? = A/B/C Heater Connection Types
A = Breaker
B = Terminal Block
C = Pullout Disconnect

Electrical Data – With Electric Heat RH2VZ (Con't.)

Installation of the U.L. Listed original equipment manufacturer provided heater kits listed in the table below is recommended for all auxiliary heating requirements.

Air Handler Model	Heater Model No.	Heater kW (208/240V)	PH/HZ	No. Elements kW Per	Circuit Type	Heater Circuit Amps	Tested Blower Motor Amps	Minimum Circuit Ampacity	Maximum Overcurrent Protection
RH2VZ4821STANAJ	RXBH-1724A15J-B	10.8/14.4	1/60	3-4.8	SINGLE	52/60	5.7	73/83	80/90
	RXBH-1724A15J-B	3.6/4.8	1/60	1-4.8	MULTIPLE CKT 1	17.4/20	5.7	29/33	30/35
		7.2/9.6	1/60	2-4.8	MULTIPLE CKT 2	34.7/40	0	44/50	45/50
	RXBH-1724A18J-B	12.8/17.0	1/60	3-5.68	SINGLE	61.6/70.9	5.7	85/96	90/100
	RXBJ-1724A18J-B	4.3/5.7	1/60	1-5.68	MULTIPLE CKT 1	20.7/23.8	5.7	33/37	35/40
		8.5/11.3	1/60	2-5.68	MULTIPLE CKT 2	40.9/47.1	0	52/59	60/60
	RXBH-24A20J-B	14.4/19.2	1/60	4-4.8	SINGLE	69.3/80	5.7	94/108	100/110
	RXBH-1724A20J-B	7.2/9.6	1/60	2-4.8	MULTIPLE CKT 1	34.7/40	5.7	51/58	60/60
		7.2/9.6	1/60	2-4.8	MULTIPLE CKT 2	34.7/40	0	44/50	45/50
	RXBH-24A25J-B	18.0/24.0	1/60	6-4.0	SINGLE	86.6/100	5.7	116/133	125/150
		6.0/8.0	1/60	2-4.0	MULTIPLE CKT 1	28.9/33.4	5.7	44/49	45/50
		6.0/8.0	1/60	2-4.0	MULTIPLE CKT 2	28.9/33.4	0	37/42	40/45
		6.0/8.0	1/60	2-4.0	MULTIPLE CKT 3	28.9/33.4	0	37/42	40/45
	RXBH-24A30J-B	21.6/28.8	1/60	6-4.8	SINGLE	103.9/120	5.7	137/158	150/175
		7.2/9.6	1/60	2-4.8	MULTIPLE CKT 1	34.7/40	5.7	51/58	60/60
		7.2/9.6	1/60	2-4.8	MULTIPLE CKT 2	34.7/40	0	44/50	45/50
		7.2/9.6	1/60	2-4.8	MULTIPLE CKT 3	34.7/40	0	44/50	45/50
	RXBH-17A05C-B	3.6/4.8	3/60	1-4.8	SINGLE	10/11.6	5.7	20/22	20/25
	RXBH-24A05C-B	3.6/4.8	3/60	1-4.8	SINGLE	10/11.6	5.7	20/22	20/25
	RXBH-1724B05C-B	3.6/4.8	3/60	1-4.8	SINGLE	10/11.6	5.7	20/22	20/25
	RXBH-1724A07C-B	5.4/7.2	3/60	2-3.6	SINGLE	15/17.4	5.7	26/29	30/30
	RXBH-1724A10C-B	7.2/9.6	3/60	2-4.8	SINGLE	20/23.1	5.7	33/36	35/40
	RXBH-1724A13C-B	9.4/12.5	3/60	3-4.17	SINGLE	26.1/30.1	5.7	40/45	40/45
	RXBH-1724A15C-B	10.8/14.4	3/60	3-4.8	SINGLE	30/34.7	5.7	45/51	45/60
	RXBH-1724A18C-B	12.8/17.0	3/60	3-5.68	SINGLE	35.6/40.9	5.7	52/59	60/60
	RXBH-24A20C-B	14.4/19.2	3/60	4-4.8	SINGLE	40/46.2	5.7	58/65	60/70
	RXBH-1724A20J-B	7.2/9.6	3/60	2-4.8	MULTIPLE CKT 1	20/23.1	5.7	33/36	35/40
		7.2/9.6	3/60	2-4.8	MULTIPLE CKT 2	20/23.1	0	25/29	25/30
	RXBH-24A25C-B	18.0/24.0	3/60	6-4.0	SINGLE	50/57.7	5.7	70/80	70/80
	RXBH-1724A20J-B	9.0/12.0	3/60	3-4.0	MULTIPLE CKT 1	25/28.9	5.7	39/44	40/45
		9.0/12.0	3/60	3-4.0	MULTIPLE CKT 2	25/28.9	0	32/37	35/40
	RXBH-24A30C-B	21.6/28.8	3/60	6-4.8	SINGLE	60/69.3	5.7	83/94	90/100
RXBH-1724A20J-B	10.8/14.4	3/60	3-4.8	MULTIPLE CKT 1	30/34.7	5.7	45/51	45/60	
	10.8/14.4	3/60	3-4.8	MULTIPLE CKT 2	30/34.7	0	38/44	40/45	

? = A/B/C Heater Connection Types

A = Breaker

B = Terminal Block

C = Pullout Disconnect

Electrical Data – With Electric Heat RH2VZ (Con't.)

Installation of the U.L. Listed original equipment manufacturer provided heater kits listed in the table below is recommended for all auxiliary heating requirements.

Air Handler Model	Heater Model No.	Heater kW (208/240V)	PH/HZ	No. Elements kW Per	Circuit Type	Heater Circuit Amps	Tested Blower Motor Amps	Minimum Circuit Ampacity	Maximum Overcurrent Protection
RH2VZ4824STANNJ	RXBH-1724?03J-B	2.3/3.0	1/60	1-3.0	SINGLE	11.1/12.5	5.1	21/22	25/25
	RXBH-1724?05J-B	3.6/4.8	1/60	1-4.8	SINGLE	17.4/20	5.1	29/32	30/35
	RXBH-1724?07J-B	5.4/7.2	1/60	2-3.6	SINGLE	26/30	5.1	39/44	40/45
	RXBH-1724?10J-B	7.2/9.6	1/60	2-4.8	SINGLE	34.7/40	5.1	50/57	50/60
	RXBH-1724A13J-B	9.4/12.5	1/60	3-4.17	SINGLE	45.2/52.1	5.1	63/72	70/80
		3.1/4.2	1/60	1-4.17	MULTIPLE CKT 1	15/17.5	5.1	26/29	30/30
		6.3/8.3	1/60	2-4.17	MULTIPLE CKT 2	30.3/34.6	0	38/44	40/45
	RXBH-1724A15J-B	10.8/14.4	1/60	3-4.8	SINGLE	52/60	5.1	72/82	80/90
	RXBH-1724A15J-B	3.6/4.8	1/60	1-4.8	MULTIPLE CKT 1	17.4/20	5.1	29/32	30/35
		7.2/9.6	1/60	2-4.8	MULTIPLE CKT 2	34.7/40	0	44/50	45/50
	RXBH-1724A18J-B	12.8/17.0	1/60	3-5.68	SINGLE	61.6/70.9	5.1	84/95	90/100
	RXBJ-1724A18J-B	4.3/5.7	1/60	1-5.68	MULTIPLE CKT 1	20.7/23.8	5.1	33/37	35/40
		8.5/11.3	1/60	2-5.68	MULTIPLE CKT 2	40.9/47.1	0	52/59	60/60
	RXBH-24A20J-B	14.4/19.2	1/60	4-4.8	SINGLE	69.3/80	5.1	93/107	100/110
	RXBH-1724A20J-B	7.2/9.6	1/60	2-4.8	MULTIPLE CKT 1	34.7/40	5.1	50/57	50/60
		7.2/9.6	1/60	2-4.8	MULTIPLE CKT 2	34.7/40	0	44/50	45/50
	RXBH-24A25J-B	18.0/24.0	1/60	6-4.0	SINGLE	86.6/100	5.1	115/132	125/150
		6.0/8.0	1/60	2-4.0	MULTIPLE CKT 1	28.9/33.4	5.1	43/49	45/50
		6.0/8.0	1/60	2-4.0	MULTIPLE CKT 2	28.9/33.4	0	37/42	40/45
		6.0/8.0	1/60	2-4.0	MULTIPLE CKT 3	28.9/33.4	0	37/42	40/45
	RXBH-24A30J-B	21.6/28.8	1/60	6-4.8	SINGLE	103.9/120	5.1	137/157	150/175
	"RXBH-1724A30J-B"	7.2/9.6	1/60	2-4.8	MULTIPLE CKT 1	34.7/40	5.1	50/57	50/60
		7.2/9.6	1/60	2-4.8	MULTIPLE CKT 2	34.7/40	0	44/50	45/50
		7.2/9.6	1/60	2-4.8	MULTIPLE CKT 3	34.7/40	0	44/50	45/50
	RXBH-17A05C-B	3.6/4.8	3/60	1-4.8	SINGLE	10/11.6	5.1	19/21	20/25
	RXBH-24A05C-B	3.6/4.8	3/60	1-4.8	SINGLE	10/11.6	5.1	19/21	20/25
	RXBH-1724B05C-B	3.6/4.8	3/60	1-4.8	SINGLE	10/11.6	5.1	19/21	20/25
	RXBH-1724A07C-B	5.4/7.2	3/60	2-3.6	SINGLE	15/17.4	5.1	26/29	30/30
	RXBH-1724A10C-B	7.2/9.6	3/60	2-4.8	SINGLE	20/23.1	5.1	32/36	35/40
	RXBH-1724A13C-B	9.4/12.5	3/60	3-4.17	SINGLE	26.1/30.1	5.1	39/44	40/45
	RXBH-1724A15C-B	10.8/14.4	3/60	3-4.8	SINGLE	30/34.7	5.1	44/50	45/50
	RXBH-1724A18C-B	12.8/17.0	3/60	3-5.68	SINGLE	35.6/40.9	5.1	51/58	60/60
	RXBH-24A20C-B	14.4/19.2	3/60	4-4.8	SINGLE	40/46.2	5.1	57/65	60/70
	RXBH-1724A20J-B	7.2/9.6	3/60	2-4.8	MULTIPLE CKT 1	20/23.1	5.1	32/36	35/40
		7.2/9.6	3/60	2-4.8	MULTIPLE CKT 2	20/23.1	0	25/29	25/30
	RXBH-24A25C-B	18.0/24.0	3/60	6-4.0	SINGLE	50/57.7	5.1	69/79	70/80
	RXBH-1724A20J-B	9.0/12.0	3/60	3-4.0	MULTIPLE CKT 1	25/28.9	5.1	38/43	40/45
		9.0/12.0	3/60	3-4.0	MULTIPLE CKT 2	25/28.9	0	32/37	35/40
	RXBH-24A30C-B	21.6/28.8	3/60	6-4.8	SINGLE	60/69.3	5.1	82/93	90/100
	RXBH-1724A20J-B	10.8/14.4	3/60	3-4.8	MULTIPLE CKT 1	30/34.7	5.1	44/50	45/50
		10.8/14.4	3/60	3-4.8	MULTIPLE CKT 2	30/34.7	0	38/44	40/45

? = A/B/C Heater Connection Types
A = Breaker
B = Terminal Block
C = Pullout Disconnect

Electrical Data – With Electric Heat RH2VZ (Con't.)

Installation of the U.L. Listed original equipment manufacturer provided heater kits listed in the table below is recommended for all auxiliary heating requirements.

Air Handler Model	Heater Model No.	Heater kW (208/240V)	PH/HZ	No. Elements kW Per	Circuit Type	Heater Circuit Amps	Tested Blower Motor Amps	Minimum Circuit Ampacity	Maximum Overcurrent Protection
RH2VZ6021STANAJ	RXBH-1724?03J-B	2.3/3.0	1/60	1-3.0	SINGLE	11.1/12.5	5.7	21/23	25/25
	RXBH-1724?05J-B	3.6/4.8	1/60	1-4.8	SINGLE	17.4/20	5.7	29/33	30/35
	RXBH-1724?07J-B	5.4/7.2	1/60	2-3.6	SINGLE	26/30	5.7	40/45	40/45
	RXBH-1724?10J-B	7.2/9.6	1/60	2-4.8	SINGLE	34.7/40	5.7	51/58	60/60
	RXBH-1724A13J-B	9.4/12.5	1/60	3-4.17	SINGLE	45.2/52.1	5.7	64/73	70/80
		3.1/4.2	1/60	1-4.17	MULTIPLE CKT 1	15/17.5	5.7	26/29	30/30
		6.3/8.3	1/60	2-4.17	MULTIPLE CKT 2	30.3/34.6	0	38/44	40/45
	RXBH-1724A15J-B	10.8/14.4	1/60	3-4.8	SINGLE	52/60	5.7	73/83	80/90
	RXBH-1724A15J-B	3.6/4.8	1/60	1-4.8	MULTIPLE CKT 1	17.4/20	5.7	29/33	30/35
		7.2/9.6	1/60	2-4.8	MULTIPLE CKT 2	34.7/40	0	44/50	45/50
	RXBH-1724A18J-B	12.8/17.0	1/60	3-5.68	SINGLE	61.6/70.9	5.7	85/96	90/100
	RXBJ-1724A18J-B	4.3/5.7	1/60	1-5.68	MULTIPLE CKT 1	20.7/23.8	5.7	33/37	35/40
		8.5/11.3	1/60	2-5.68	MULTIPLE CKT 2	40.9/47.1	0	52/59	60/60
	RXBH-24A20J-B	14.4/19.2	1/60	4-4.8	SINGLE	69.3/80	5.7	94/108	100/110
	RXBH-1724A20J-B	7.2/9.6	1/60	2-4.8	MULTIPLE CKT 1	34.7/40	5.7	51/58	60/60
		7.2/9.6	1/60	2-4.8	MULTIPLE CKT 2	34.7/40	0	44/50	45/50
	RXBH-24A25J-B	18.0/24.0	1/60	6-4.0	SINGLE	86.6/100	5.7	116/133	125/150
		6.0/8.0	1/60	2-4.0	MULTIPLE CKT 1	28.9/33.4	5.7	44/49	45/50
		6.0/8.0	1/60	2-4.0	MULTIPLE CKT 2	28.9/33.4	0	37/42	40/45
		6.0/8.0	1/60	2-4.0	MULTIPLE CKT 3	28.9/33.4	0	37/42	40/45
	RXBH-24A30J-B	21.6/28.8	1/60	6-4.8	SINGLE	103.9/120	5.7	137/158	150/175
	RXBH-1724A30J-B	7.2/9.6	1/60	2-4.8	MULTIPLE CKT 1	34.7/40	5.7	51/58	60/60
		7.2/9.6	1/60	2-4.8	MULTIPLE CKT 2	34.7/40	0	44/50	45/50
		7.2/9.6	1/60	2-4.8	MULTIPLE CKT 3	34.7/40	0	44/50	45/50
	RXBH-17A05C-B	3.6/4.8	3/60	1-4.8	SINGLE	10/11.6	5.7	20/22	20/25
	RXBH-24A05C-B	3.6/4.8	3/60	1-4.8	SINGLE	10/11.6	5.7	20/22	20/25
	RXBH-1724B05C-B	3.6/4.8	3/60	1-4.8	SINGLE	10/11.6	5.7	20/22	20/25
	RXBH-1724A07C-B	5.4/7.2	3/60	2-3.6	SINGLE	15/17.4	5.7	26/29	30/30
	RXBH-1724A10C-B	7.2/9.6	3/60	2-4.8	SINGLE	20/23.1	5.7	33/36	35/40
	RXBH-1724A13C-B	9.4/12.5	3/60	3-4.17	SINGLE	26.1/30.1	5.7	40/45	40/45
	RXBH-1724A15C-B	10.8/14.4	3/60	3-4.8	SINGLE	30/34.7	5.7	45/51	45/60
	RXBH-1724A18C-B	12.8/17.0	3/60	3-5.68	SINGLE	35.6/40.9	5.7	52/59	60/60
	RXBH-24A20C-B	14.4/19.2	3/60	4-4.8	SINGLE	40/46.2	5.7	58/65	60/70
	RXBH-1724A20J-B	7.2/9.6	3/60	2-4.8	MULTIPLE CKT 1	20/23.1	5.7	33/36	35/40
		7.2/9.6	3/60	2-4.8	MULTIPLE CKT 2	20/23.1	0	25/29	25/30
	RXBH-24A25C-B	18.0/24.0	3/60	6-4.0	SINGLE	50/57.7	5.7	70/80	70/80
	RXBH-1724A20J-B	9.0/12.0	3/60	3-4.0	MULTIPLE CKT 1	25/28.9	5.7	39/44	40/45
		9.0/12.0	3/60	3-4.0	MULTIPLE CKT 2	25/28.9	0	32/37	35/40
	RXBH-24A30C-B	21.6/28.8	3/60	6-4.8	SINGLE	60/69.3	5.7	83/94	90/100
	RXBH-1724A20J-B	10.8/14.4	3/60	3-4.8	MULTIPLE CKT 1	30/34.7	5.7	45/51	45/60
		10.8/14.4	3/60	3-4.8	MULTIPLE CKT 2	30/34.7	0	38/44	40/45

? = A/B/C Heater Connection Types

A = Breaker

B = Terminal Block

C = Pullout Disconnect

Electrical Data – With Electric Heat RH2VZ (Con't.)

Installation of the U.L. Listed original equipment manufacturer provided heater kits listed in the table below is recommended for all auxiliary heating requirements.

Air Handler Model	Heater Model No.	Heater kW (208/240V)	PH/HZ	No. Elements kW Per	Circuit Type	Heater Circuit Amps	Tested Blower Motor Amps	Minimum Circuit Ampacity	Maximum Overcurrent Protection
RH2VZ6024STANNJ	RXBH-1724?03J-B	2.3/3.0	1/60	1-3.0	SINGLE	11.1/12.5	5.2	21/23	25/25
	RXBH-1724?05J-B	3.6/4.8	1/60	1-4.8	SINGLE	17.4/20	5.2	29/32	30/35
	RXBH-1724?07J-B	5.4/7.2	1/60	2-3.6	SINGLE	26/30	5.2	39/44	40/45
	RXBH-1724?10J-B	7.2/9.6	1/60	2-4.8	SINGLE	34.7/40	5.2	50/57	50/60
	RXBH-1724A13J-B	9.4/12.5	1/60	3-4.17	SINGLE	45.2/52.1	5.2	63/72	70/80
		3.1/4.2	1/60	1-4.17	MULTIPLE CKT 1	15/17.5	5.2	26/29	30/30
	RXBH-1724A15J-B	6.3/8.3	1/60	2-4.17	MULTIPLE CKT 2	30.3/34.6	0	38/44	40/45
		10.8/14.4	1/60	3-4.8	SINGLE	52/60	5.2	72/82	80/90
	RXBH-1724A18J-B	3.6/4.8	1/60	1-4.8	MULTIPLE CKT 1	17.4/20	5.2	29/32	30/35
		7.2/9.6	1/60	2-4.8	MULTIPLE CKT 2	34.7/40	0	44/50	45/50
	RXBH-1724A18J-B	12.8/17.0	1/60	3-5.68	SINGLE	61.6/70.9	5.2	84/96	90/100
	RXBJ-1724A18J-B	4.3/5.7	1/60	1-5.68	MULTIPLE CKT 1	20.7/23.8	5.2	33/37	35/40
		8.5/11.3	1/60	2-5.68	MULTIPLE CKT 2	40.9/47.1	0	52/59	60/60
	RXBH-24A20J-B	14.4/19.2	1/60	4-4.8	SINGLE	69.3/80	5.2	94/107	100/110
	RXBH-1724A20J-B	7.2/9.6	1/60	2-4.8	MULTIPLE CKT 1	34.7/40	5.2	50/57	50/60
		7.2/9.6	1/60	2-4.8	MULTIPLE CKT 2	34.7/40	0	44/50	45/50
	RXBH-24A25J-B	18.0/24.0	1/60	6-4.0	SINGLE	86.6/100	5.2	115/132	125/150
		6.0/8.0	1/60	2-4.0	MULTIPLE CKT 1	28.9/33.4	5.2	43/49	45/50
		6.0/8.0	1/60	2-4.0	MULTIPLE CKT 2	28.9/33.4	0	37/42	40/45
		6.0/8.0	1/60	2-4.0	MULTIPLE CKT 3	28.9/33.4	0	37/42	40/45
	RXBH-24A30J-B	21.6/28.8	1/60	6-4.8	SINGLE	103.9/120	5.2	137/157	150/175
	RXBH-1724A30J-B	7.2/9.6	1/60	2-4.8	MULTIPLE CKT 1	34.7/40	5.2	50/57	50/60
		7.2/9.6	1/60	2-4.8	MULTIPLE CKT 2	34.7/40	0	44/50	45/50
		7.2/9.6	1/60	2-4.8	MULTIPLE CKT 3	34.7/40	0	44/50	45/50
	RXBH-17A05C-B	3.6/4.8	3/60	1-4.8	SINGLE	10/11.6	5.2	19/21	20/25
	RXBH-24A05C-B	3.6/4.8	3/60	1-4.8	SINGLE	10/11.6	5.2	19/21	20/25
	RXBH-1724B05C-B	3.6/4.8	3/60	1-4.8	SINGLE	10/11.6	5.2	19/21	20/25
	RXBH-1724A07C-B	5.4/7.2	3/60	2-3.6	SINGLE	15/17.4	5.2	26/29	30/30
	RXBH-1724A10C-B	7.2/9.6	3/60	2-4.8	SINGLE	20/23.1	5.2	32/36	35/40
	RXBH-1724A13C-B	9.4/12.5	3/60	3-4.17	SINGLE	26.1/30.1	5.2	40/45	40/45
	RXBH-1724A15C-B	10.8/14.4	3/60	3-4.8	SINGLE	30/34.7	5.2	44/50	45/50
	RXBH-1724A18C-B	12.8/17.0	3/60	3-5.68	SINGLE	35.6/40.9	5.2	51/58	60/60
	RXBH-24A20C-B	14.4/19.2	3/60	4-4.8	SINGLE	40/46.2	5.2	57/65	60/70
	RXBH-1724A20J-B	7.2/9.6	3/60	2-4.8	MULTIPLE CKT 1	20/23.1	5.2	32/36	35/40
		7.2/9.6	3/60	2-4.8	MULTIPLE CKT 2	20/23.1	0	25/29	25/30
	RXBH-24A25C-B	18.0/24.0	3/60	6-4.0	SINGLE	50/57.7	5.2	69/79	70/80
	RXBH-1724A20J-B	9.0/12.0	3/60	3-4.0	MULTIPLE CKT 1	25/28.9	5.2	38/43	40/45
		9.0/12.0	3/60	3-4.0	MULTIPLE CKT 2	25/28.9	0	32/37	35/40
	RXBH-24A30C-B	21.6/28.8	3/60	6-4.8	SINGLE	60/69.3	5.2	82/94	90/100
	RXBH-1724A20J-B	10.8/14.4	3/60	3-4.8	MULTIPLE CKT 1	30/34.7	5.2	44/50	45/50
10.8/14.4		3/60	3-4.8	MULTIPLE CKT 2	30/34.7	0	38/44	40/45	

? = A/B/C Heater Connection Types
A = Breaker
B = Terminal Block
C = Pullout Disconnect

Electrical Wiring

Power Wiring

- Field wiring must comply with the National Electrical Code (C.E.C. in Canada) and any applicable local ordinance.
- Supply wiring must be 75°C minimum copper conductors only.
- See electrical data for product Ampacity rating and Circuit Protector requirement.

Accessories

• Combustible Floor Base RXHB-

Model Cabinet Size	Combustible Floor Base Model Number
17	RXHB-17
21	RXHB-21
24	RXHB-24

- **Jumper Bar Kit 3 Ckt. to 1 Ckt. RXBJ-A31** is used to convert single phase multiple three circuit units to a single supply circuit. Kit includes cover and screw for line side terminals.
- **Jumper Bar Kit 2 Ckt. to 1 Ckt. RXBJ-A21** is used to convert single phase multiple two circuit units to a single supply circuit. Kit includes cover and screw for line side terminals.
- **Note:** No jumper bar kit is available to convert three phase multiple two circuit units to a single supply circuit.
- **Auxiliary Horizontal Overflow Pan Accessory RXBM-**

Nominal Cooling Capacity-Tons	Auxiliary Horizontal Overflow Pan Accessory Model Number
1 1/2 - 3	RXBM-AC48
3 1/2 - 5	RXBM-AC61

Grounding

- This product must be sufficiently grounded in accordance with National Electrical Code (C.E.C. in Canada) and any applicable local ordinance.
- A grounding lug is provided.

• Auxiliary Electric Heater Kits RXBH-

Heater Kits include circuit breakers which meet UL and cUL requirements for service disconnect. See the Electric Heat Electrical Data in this specification sheet for specific Heater Kit Model numbers.

• Horizontal Adapter Kit RXHH-

This horizontal adapter kit is used to convert Upflow/Downflow only models to horizontal flow. See the following table to order proper horizontal adapter kit.

Coil Model	Horizontal Adapter Kit Model Number (Single Qty.)	Horizontal Adapter Kit Model Number (10-Pack Qty.)
2414	RXHH-A01	RXHH-A01 x 10
2417	RXHH-A02	RXHH-A02 x 10
3617/3621	RXHH-A03	RXHH-A03 x 10
3821/4821/4824	RXHH-A04	RXHH-A04 x 10
3621HT/4821MT/6021ST	RXHH-06	RXHH-06 x 10
6024	RXHH-A05	RXHH-A05 x 10

• External Filter Base RXHF-

Model Cabinet Size	Filter Size In. [mm]	Part Number*	A	B
17	16 x 20 [406 x 508]	RXHF-17	15.70	17.5
21	20 x 20 [508 x 508]	RXHF-21	19.20	21.0
24	25 x 20 [635 x 508]	RXHF-24	22.70	25.5

*Accommodates 1" or 2" filter

[] Designates Metric Conversions

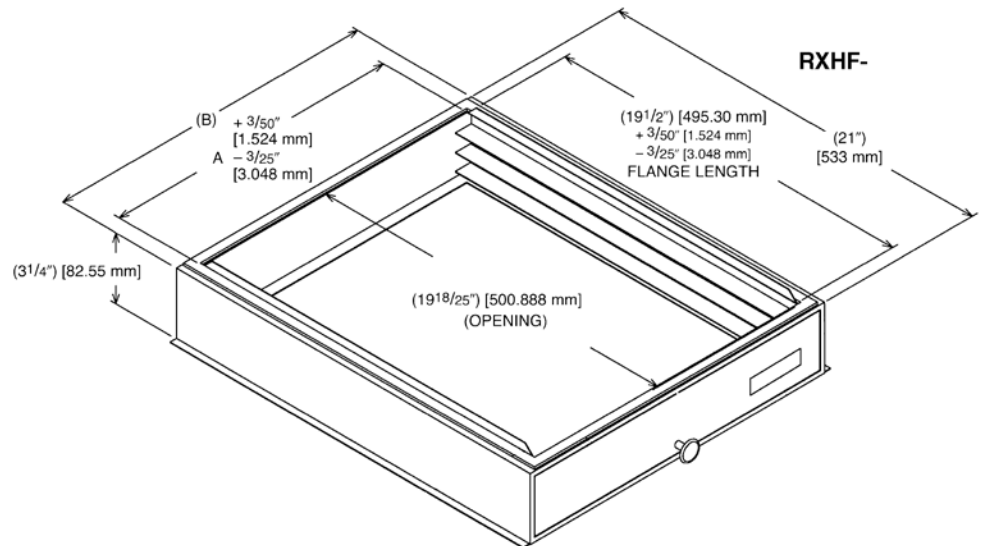
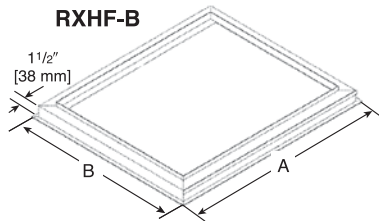



The new degree of comfort.®

Endeavor™ Line Air Handlers



RH3VZ

Motor: Constant CFM

Airflow Stages: 3-Stage

Expansion Device: Thermal Expansion Valve (TXV)

Efficiencies: Up to 16 SEER2



Table of Contents

Features & Benefits	3
Model Number Identification	4
Dimensional Data	5-6
Unit Dimensions & Weights	7
Airflow Directional Data	8
Airflow Performance Data	9
Electrical Data	10-14
Limited Warranty	16

Features and Benefits

- **Constant CFM Motor:** When paired with the EcoNet® Smart Thermostat, the motor gradually auto-adjusts from low capacity to 100% of capacity to meet comfort requirements – allowing for ultimate humidity control, quieter sounds levels and year-round energy savings

When paired with a 24V two-stage thermostat, the air handler runs in 3-speeds to match airflow with outdoor unit

- **PlusOne® Diagnostics - Easy & Quick Diagnostics & Ongoing Monitoring with Bluetooth Technology & EcoNet®:** With the Rheem Contractor & EcoNet® Apps, built-in technology makes monitoring, troubleshooting and repairing the product easier than ever before

The Rheem® Endeavor™ Line with the Rheem® Contractor App via Bluetooth technology, features up to 62% faster overall diagnostics over other residential HVAC brands¹

- **No Dip Switches = Fast Seamless Final Installation:** The Rheem Endeavor™ Line, with Rheem® Contractor App-based commissioning via Bluetooth technology, features up to 54% faster installation over other residential HVAC brands*

- **New Rheem® Air Handler Control Board (AHC):** Enables constant CFM airflow

Introduces Bluetooth connectivity for access to advanced diagnostic information from the Contractor App on your mobile device

Maintains EcoNet® diagnostics for remote access when shared by the homeowner

[] Designates Metric Conversions

- **Aluminum Indoor Coil Design:** Are constructed of aluminum fins bonded to internally grooved aluminum tubing and are more corrosion resistant
- **Quieter Sound Levels:** Provided by sturdy cabinet construction with 1.0 inch of foil faced insulation for quieter sound characteristics
- **Versatile 4-Way Convertible Compact Design:** Allows for upflow, downflow, horizontal left and horizontal right applications, even in the smallest of spaces
- **Rugged Steel, Compact Cabinet Construction:** Designed for added strength and versatility
- **Field-installed Auxiliary Heater Kits:** Provide exact heat for indoor comfort and include circuit breakers which meet UL and cUL requirements for service disconnect
- **Less than 2% Cabinet Air Leakage at 1-inch H₂O:** When tested in accordance with ASHRAE Standard 193

¹Per a 2022 MIAT Residential HVAC Time Study on base and mid-tier Endeavor™ Line products and commercially available competitor units of similar product tier.

Air Handlers

<u>R</u>	<u>H</u>	<u>3</u>	<u>V</u>	<u>Z</u>	<u>24</u>	<u>17</u>	<u>S</u>	<u>T</u>	<u>A</u>	<u>C</u>	<u>N</u>	<u>J</u>
Brand	Product Category	Stages Of Airflow	Motor Type	Refrigerant	Capacity	Width	Efficiency	Metering	Major Series	Controls	Coil Series	Voltage
R - Rheem	H - Multipoise Air Handler	3 - 3+ Stage	V - Constant CFM	Z - R-410A	24 - 2.0T 36 - 3.0T 48 - 4.0T 60 - 5.0T	17 - 17.5" 21 - 21" 24 - 24.5"	S - Standard	T - TXV	A - 1st Design	C - Communicating	N - N Coil	J - 208-240/1/60

AVAILABLE MODELS
RH3VZ2417STACNJ
RH3VZ3617STACNJ
RH3VZ4821STACNJ
RH3VZ6024STACNJ

STANDARD EQUIPMENT
Equipped standard with an EcoNet® Air Handler control board that allows it to directly communicate with the EcoNet® Smart Thermostat. The EcoNet® Smart Thermostat serves as the hub of communication for a home's Heating, Cooling, and Water Heating systems, and is required to operate an EcoNet® Enabled Heating and Cooling system in fully communicating mode. Built in WiFi enables remote operation of EcoNet® Enabled equipment from the mobile-friendly web portal or mobile apps.
WiFi broadband internet connection required. Download the EcoNet® App from the App Store or Google Play to set up your EcoNet® Smart Thermostat. Receipt of notification depend on home WiFi set up. WiFi broadband internet connection required.
Selectable continuous fan "on" options.
The most compact unit design available, all standard heat air handler models only 42-1/2 to 57 inches [1079 to 1448 mm] high.
Attractive pre-painted cabinet exterior.
Rugged steel cabinet construction, designed for added strength and versatility.
1.0" foil faced insulation mechanically retained in blower compartment.
Four leg rubber insulated motor mount.
Field-installed auxiliary heater kit includes circuit breakers that meet UL and cUL requirements as a service disconnect switch.
Blower housing with integrated controls, motor and blower. Slide out design for service and maintenance convenience.
Field convertible for vertical upflow, vertical downflow, horizontal left hand or right hand air supply.
3 combustible floor base accessories fit all model sizes when required for downflow installations on combustible floors.
Indoor coil design provides low air side pressure drop, high performance and extremely compact size. All coils come with PVC condensate elbow standard.
Coils are constructed of aluminum fins bonded to internally grooved aluminum tubing.
Coils are tested at the factory with an extensive refrigerant leak check.
Coils have copper sweat refrigerant connections.
Coils utilize chatleff metering device connections.
Molded polymer corrosion resistant condensate drain pan is provided on all indoor coils.
Supply duct flanges provided as standard on air handler cabinet.
Provisions for field electrical connections available from either side or top of the air handler cabinet.
Connection point for high voltage wiring is inside the air handler cabinet. Low voltage connection is made on the outside of the air handler cabinet.
Concentric knockouts are provided for power connection to cabinet. Installer may pull desired hole size up to 2 inches [51 mm] for 1-1/2 inch [38 mm] conduit.
Front refrigerant and drain connections.

[] Designates Metric Conversions

Unit Dimensions

Return Air Opening Dimensions

Model Cabinet Size	Return Air Opening Width (Inches)	Return Air Opening Depth/Length (Inches)
17	15 ⁷ / ₈	19 ³ / ₄
21	19 ³ / ₈	19 ³ / ₄
24	22 ⁷ / ₈	19 ³ / ₄

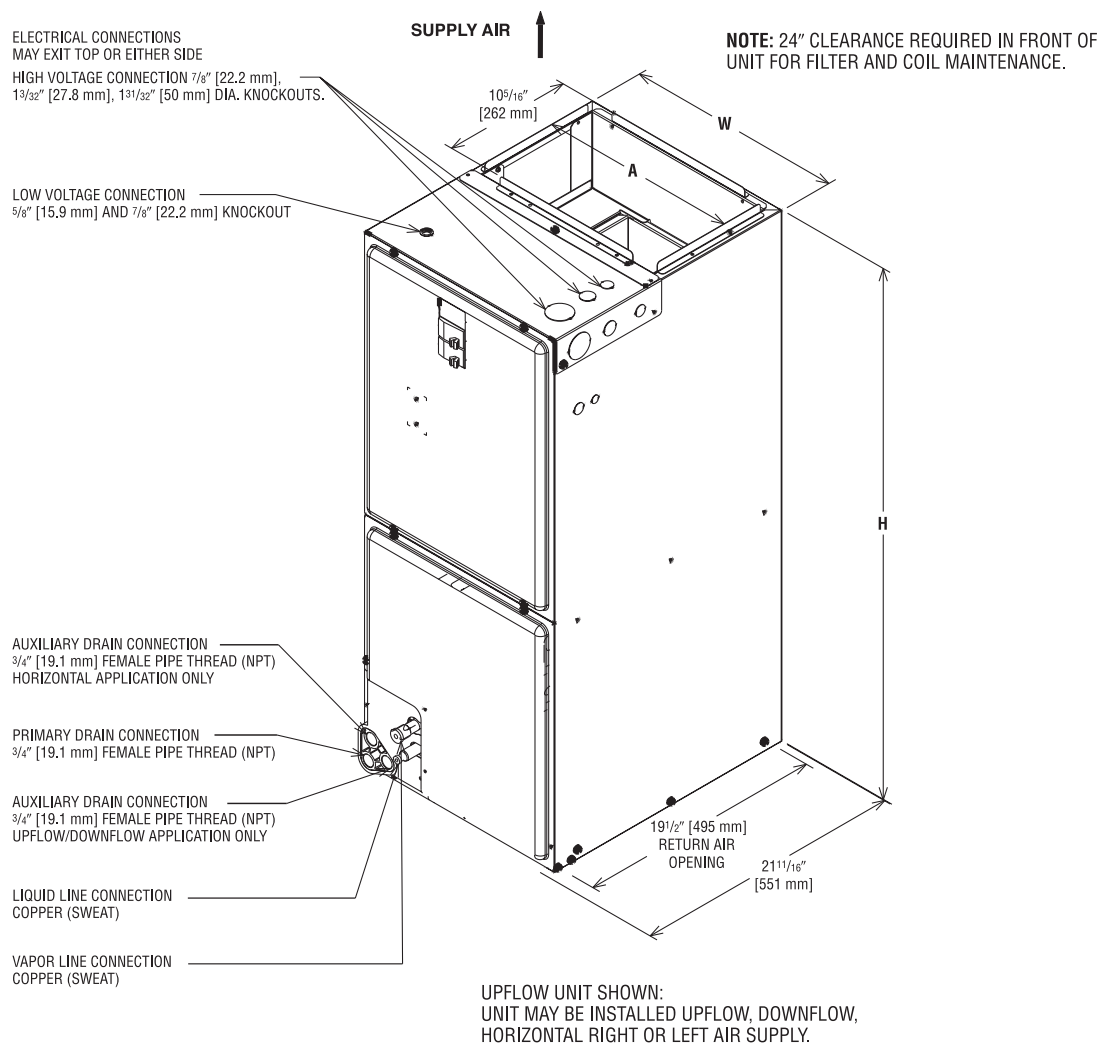

[] Designates Metric Conversions

FIGURE 6
VERTICAL DOWNFLOW & HORIZONTAL RIGHT APPLICATION

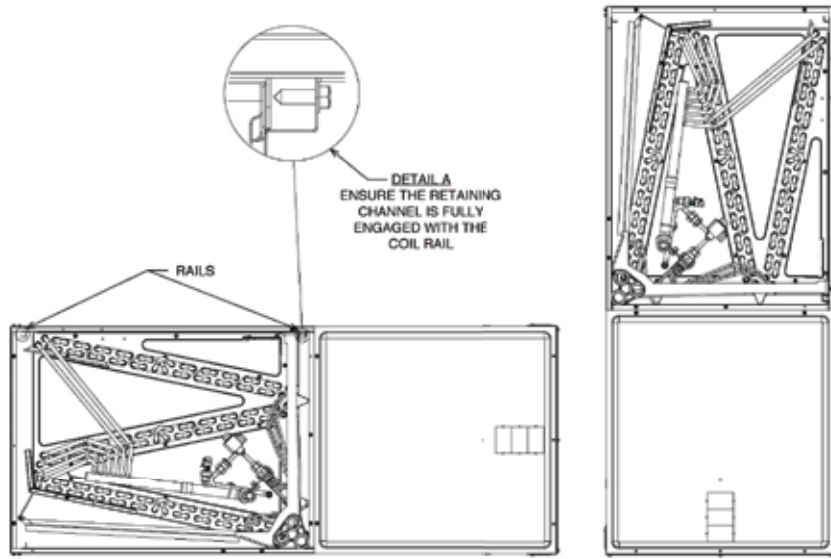
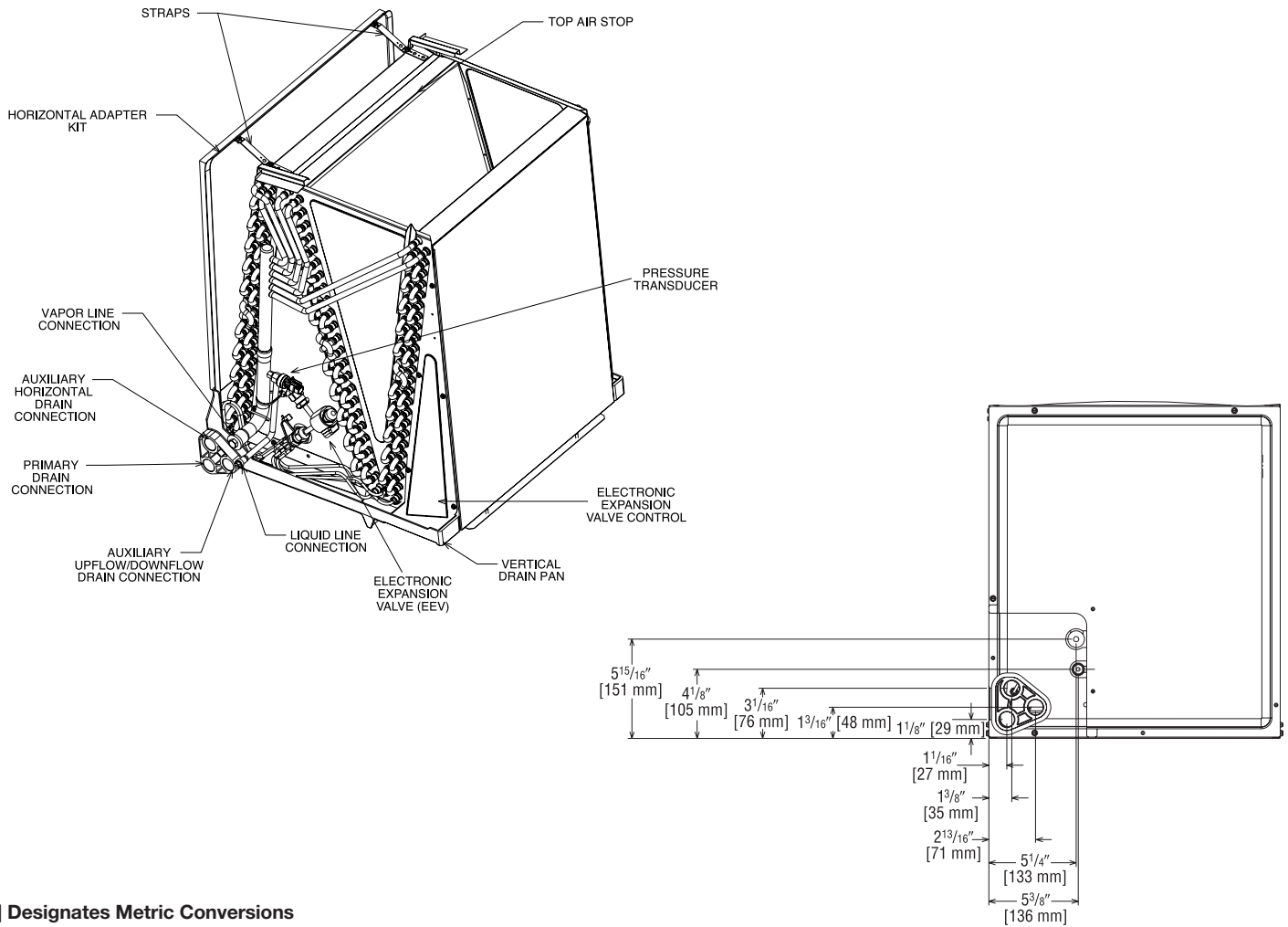

FIGURE 7
INDOOR COIL AND DRAIN PAN SET-UP



[] Designates Metric Conversions

Unit Dimensions & Weights

Model Size RH3VZ	Refrigerant Connections Sweat (In.) [mm] ID		Unit Width "W" In. [mm]	Unit Height "H" In. [mm]	Supply Duct "A" In. [mm]	Unit Weight/ Shipping Weight (Lbs.) [kg]
	Liquid	Vapor				
2417STACN	3/8 [9.53]	3/4 [19.05]	17 1/2 [444.5]	42 1/2 [1080]	16 [406]	91/105 [41/48]
3617STACN	3/8 [9.53]	3/4 [19.05]	17 1/2 [444.5]	42 1/2 [1080]	16 [406]	99/113 [45/51]
4821STACN	3/8 [9.53]	7/8 [22.23]	21 [533.0]	50 1/2 [1282]	19 1/2 [495]	129/145 [59/66]
6024STACN	3/8 [9.53]	7/8 [22.23]	24 1/2 [622.3]	55 1/2 [1410]	23 [584]	158/175 [72/79]

[] Designates Metric Conversions

Airflow Directional Data

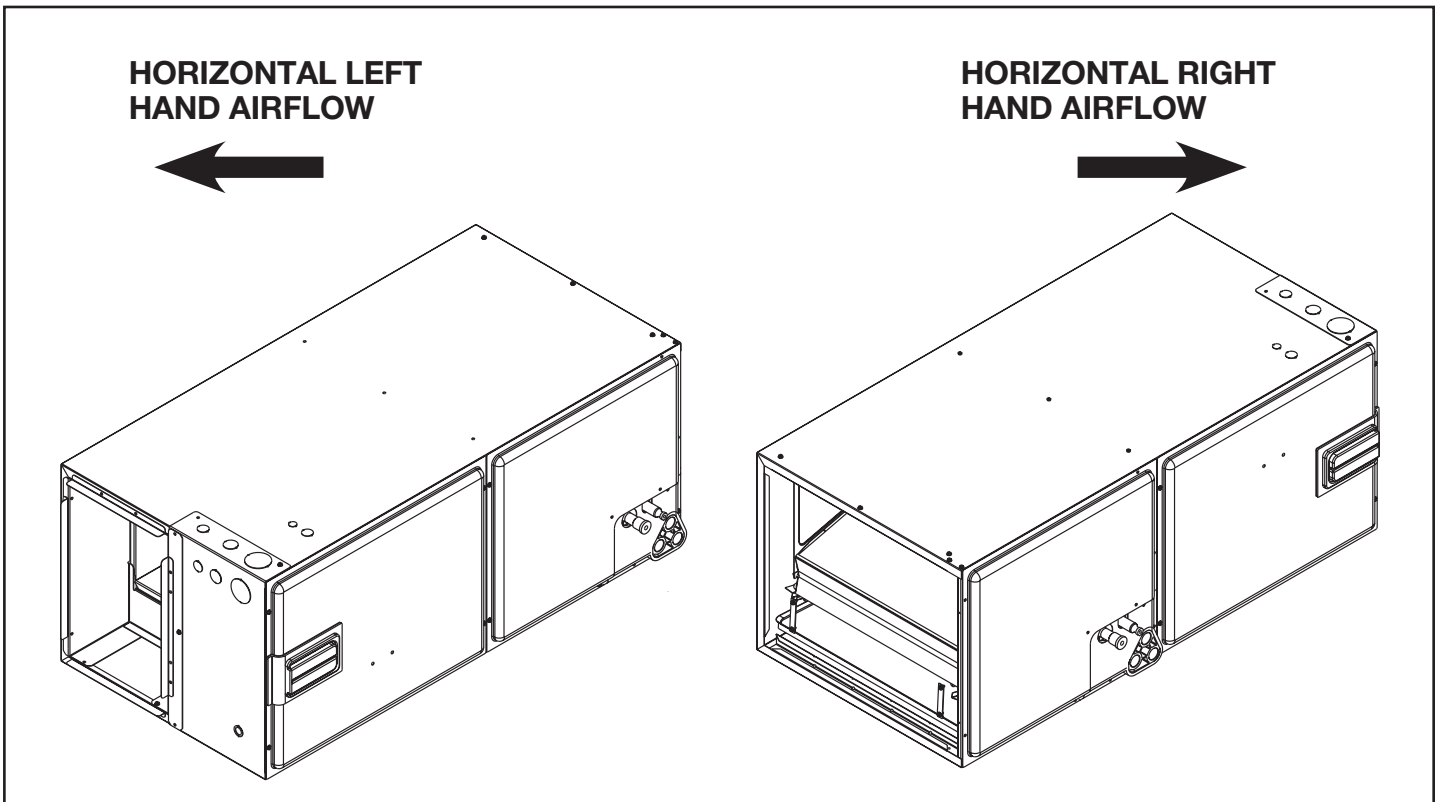
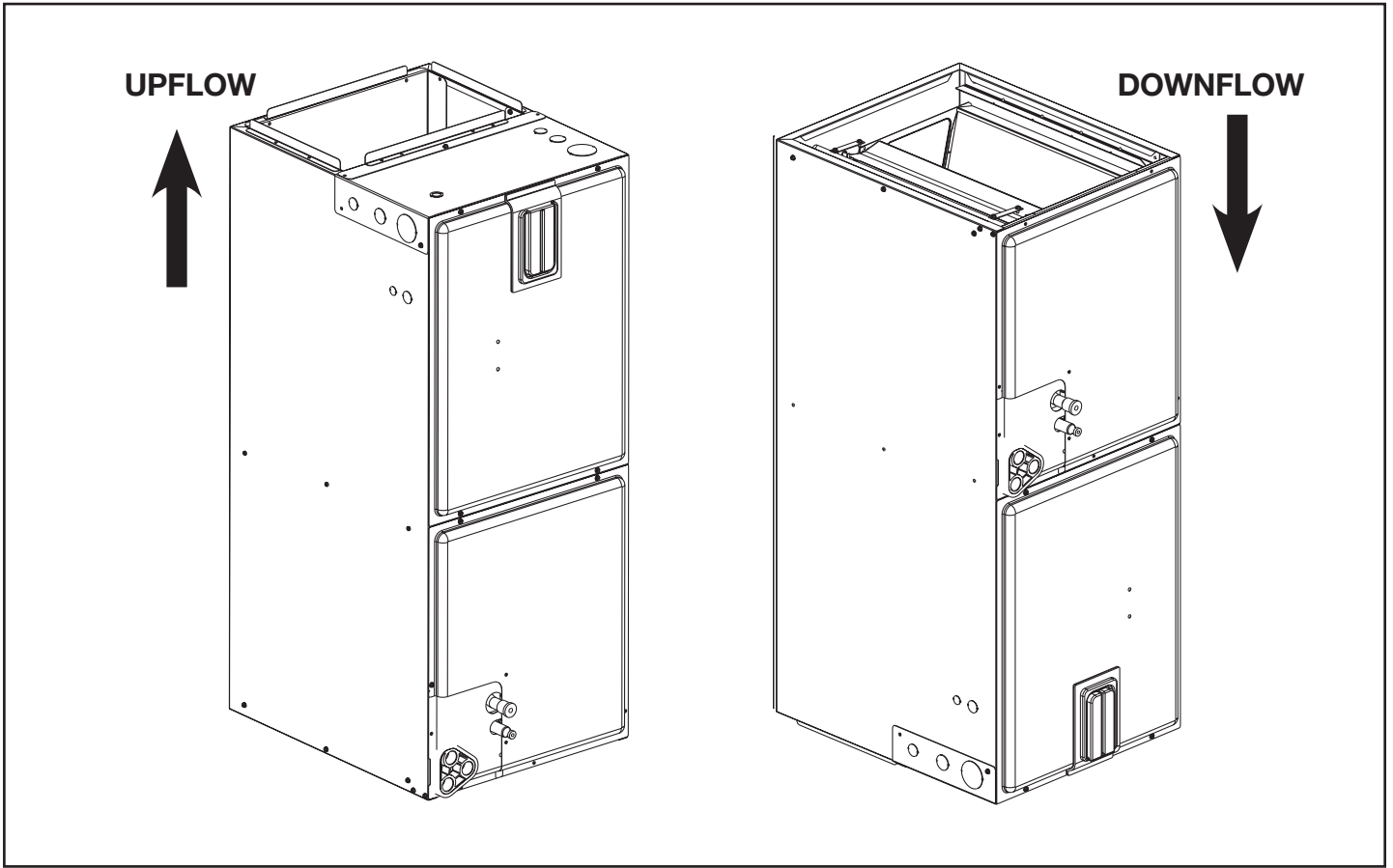

208V/240V Airflow Performance Data – RH3V (Constant Torque (ECM) Motor)

Rated Airflow for RH3VZ Air-Handlers + RA15/RA16 Condensing Units & RP16 Heat Pumps					
Air Handler Model	Outdoor Model	RH3VZ Airflow (EcoNet®)			
		Cooling Mode CFM [L/s]		Heating Mode CFM [L/s]	
		Minimum	Maximum	Minimum	Maximum
RH3VZ2417STACN	RA15AZ24	340 [160]	750 [354]	—	—
	RA16AZ24	340 [160]	750 [354]	—	—
	RP16AZ24	360 [170]	750 [354]	360 [170]	750 [354]
RH3VZ3617STACN	RA15AZ36	500 [236]	1125 [531]	—	—
	RA16AZ36	500 [236]	1125 [531]	—	—
	RP16AZ36	500 [236]	1125 [531]	500 [236]	1125 [531]
RH3VZ4821STACN	RA15AZ48	650 [307]	1450 [684]	—	—
	RA16AZ48	650 [307]	1450 [684]	—	—
	RP16AZ48	650 [307]	1450 [684]	650 [307]	1450 [684]
RH3VZ6024STACN	RA15AZ60	810 [382]	1800 [850]	—	—
	RA16AZ60	810 [382]	1800 [850]	—	—
	RP16AZ60	810 [382]	1800 [850]	810 [382]	1800 [850]

[] Designates Metric Conversions

Electrical Data – Blower Motor Only – No Electric Heat RH3V

Model RH3VZ	Voltage	Phase*	Hertz	HP [W]	RPM	Motor Amps.	Minimum Circuit Ampacity	Maximum Overcurrent Protection
2417STACNJ	208/240	1	60	1/3 [249]	300-1300	2.8	4	15
3617STACNJ				1/2 [373]	300-1300	4.6	6	15
4821STACNJ				3/4 [559]	300-1300	5.4	7	15
6024STACNJ				3/4 [559]	300-1300	5.2	7	15

*Blower motors are all single-phase motors

[] Designates Metric Conversions

Electrical Data – With Electric Heat RH3V

Installation of the U.L. Listed original equipment manufacturer provided heater kits listed in the following table is recommended for all auxiliary heating requirements.

Air Handler Model	Heater Model Number	Heater kW (208/240V)	Ph/Hz	No. Elements – kW per	Type Supply Circuit Single Circuit Multiple Circuit	Heater Amps.	Blower Motor Amps	Minimum Circuit Ampacity	Maximum Overcurrent Protection
RH3VZ2417STACNJ	RXBH-1724?03J-B	2.3/3.0	1/60	1-3.0	SINGLE	11.1/12.5	2.8	18/20	20/20
	RXBH-1724?05J-B	3.6/4.8	1/60	1-4.8	SINGLE	17.4/20	2.8	26/29	30/30
	RXBH-1724?07J-B	5.4/7.2	1/60	2-3.6	SINGLE	26/30	2.8	36/41	40/45
	RXBH-1724?10J-B	7.2/9.6	1/60	2-4.8	SINGLE	34.7/40	2.8	47/54	50/60
	RXBH-1724A13J-B	9.4/12.5	1/60	3-4.17	SINGLE	45.2/52.1	2.8	60/69	60/70
		3.1/4.2	1/60	1-4.17	MULTIPLE CKT 1	15/17.5	2.8	23/26	25/30
		6.3/8.3	1/60	2-4.17	MULTIPLE CKT 2	30.3/34.6	0	38/44	40/45
	RXBH-17A05C-B	3.6/4.8	3/60	1-4.8	SINGLE	10/11.6	2.8	16/18	20/20
	RXBH-24A05C-B	3.6/4.8	3/60	1-4.8	SINGLE	10/11.6	2.8	16/18	20/20
	RXBH-1724B05C-B	3.6/4.8	3/60	1-4.8	SINGLE	10/11.6	2.8	16/18	20/20
	RXBH-1724A07C-B	5.4/7.2	3/60	2-3.6	SINGLE	15/17.4	2.8	23/26	25/30
	RXBH-1724A10C-B	7.2/9.6	3/60	2-4.8	SINGLE	20/23.1	2.8	29/33	30/35
	RXBH-1724A13C-B	9.4/12.5	3/60	3-4.17	SINGLE	26.1/30.1	2.8	37/42	40/45
RH3VZ3617STACNJ	RXBH-1724?03J-B	2.3/3.0	1/60	1-3.0	SINGLE	11.1/12.5	4.6	20/22	20/25
	RXBH-1724?05J-B	3.6/4.8	1/60	1-4.8	SINGLE	17.4/20	4.6	28/31	30/35
	RXBH-1724?07J-B	5.4/7.2	1/60	2-3.6	SINGLE	26/30	4.6	39/44	40/45
	RXBH-1724?10J-B	7.2/9.6	1/60	2-4.8	SINGLE	34.7/40	4.6	50/56	50/60
	RXBH-1724A13J-B	9.4/12.5	1/60	3-4.17	SINGLE	45.2/52.1	4.6	63/71	70/80
		3.1/4.2	1/60	1-4.17	MULTIPLE CKT 1	15/17.5	4.6	25/28	25/30
		6.3/8.3	1/60	2-4.17	MULTIPLE CKT 2	30.3/34.6	0	38/44	40/45
	RXBH-1724A15J-B	10.8/14.4	1/60	3-4.8	SINGLE	52/60	4.6	71/81	80/90
	RXBH-1724A15J-B	3.6/4.8	1/60	1-4.8	MULTIPLE CKT 1	17.4/20	4.6	28/31	30/35
		7.2/9.6	1/60	2-4.8	MULTIPLE CKT 2	34.7/40	0	44/50	45/50
	RXBH-1724A18J-B	12.8/17.0	1/60	3-5.68	SINGLE	61.6/70.9	4.6	83/95	90/100
	RXBJ-1724A18J-B	4.3/5.7	1/60	1-5.68	MULTIPLE CKT 1	20.7/23.8	4.6	32/36	35/40
		8.5/11.3	1/60	2-5.68	MULTIPLE CKT 2	40.9/47.1	0	52/59	60/60
	RXBH-17A05C-B	3.6/4.8	3/60	1-4.8	SINGLE	10/11.6	4.6	19/21	20/25
	RXBH-24A05C-B	3.6/4.8	3/60	1-4.8	SINGLE	10/11.6	4.6	19/21	20/25
	RXBH-1724B05C-B	3.6/4.8	3/60	1-4.8	SINGLE	10/11.6	4.6	19/21	20/25
	RXBH-1724A07C-B	5.4/7.2	3/60	2-3.6	SINGLE	15/17.4	4.6	25/28	25/30
	RXBH-1724A10C-B	7.2/9.6	3/60	2-4.8	SINGLE	20/23.1	4.6	31/35	35/35
	RXBH-1724A13C-B	9.4/12.5	3/60	3-4.17	SINGLE	26.1/30.1	4.6	39/44	40/45
	RXBH-1724A15C-B	10.8/14.4	3/60	3-4.8	SINGLE	30/34.7	4.6	44/50	45/50
	RXBH-1724A18C-B	12.8/17.0	3/60	3-5.68	SINGLE	35.6/40.9	4.6	51/57	60/60

? = A/B/C Heater Connection Types

A = Breaker

B = Terminal Block

C = Pullout Disconnect

[] Designates Metric Conversions

Electrical Data – With Electric Heat RH3V (Con't.)

Installation of the U.L. Listed original equipment manufacturer provided heater kits listed in the following table is recommended for all auxiliary heating requirements.

Air Handler Model	Heater Model Number	Heater kW (208/240V)	Ph/Hz	No. Elements – kW per	Type Supply Circuit Single Circuit Multiple Circuit	Heater Amps.	Blower Motor Amps	Minimum Circuit Ampacity	Maximum Overcurrent Protection
RH3VZ4821STACNJ	RXBH-1724703J-B	2.3/3.0	1/60	1-3.0	SINGLE	11.1/12.5	5.4	21/23	25/25
	RXBH-1724705J-B	3.6/4.8	1/60	1-4.8	SINGLE	17.4/20	5.4	29/32	30/35
	RXBH-1724707J-B	5.4/7.2	1/60	2-3.6	SINGLE	26/30	5.4	40/45	40/45
	RXBH-1724710J-B	7.2/9.6	1/60	2-4.8	SINGLE	34.7/40	5.4	51/57	60/60
	RXBH-1724A13J-B	9.4/12.5	1/60	3-4.17	SINGLE	45.2/52.1	5.4	64/72	70/80
	RXBH-1724A13J-B	3.1/4.2	1/60	1-4.17	MULTIPLE CKT 1	15/17.5	5.4	26/29	30/30
		6.3/8.3	1/60	2-4.17	MULTIPLE CKT 2	30.3/34.6	0	38/44	40/45
	RXBH-1724A15J-B	10.8/14.4	1/60	3-4.8	SINGLE	52/60	5.4	72/82	80/90
	RXBH-1724A15J-B	3.6/4.8	1/60	1-4.8	MULTIPLE CKT 1	17.4/20	5.4	29/32	30/35
		7.2/9.6	1/60	2-4.8	MULTIPLE CKT 2	34.7/40	0	44/50	45/50
	RXBH-1724A18J-B	12.8/17.0	1/60	3-5.68	SINGLE	61.6/70.9	5.4	84/96	90/100
	RXBJ-1724A18J-B	4.3/5.7	1/60	1-5.68	MULTIPLE CKT 1	20.7/23.8	5.4	33/37	35/40
		8.5/11.3	1/60	2-5.68	MULTIPLE CKT 2	40.9/47.1	0	52/59	60/60
	RXBH-24A20J-B	14.4/19.2	1/60	4-4.8	SINGLE	69.3/80	5.4	94/107	100/110
	RXBH-1724A20J-B	7.2/9.6	1/60	2-4.8	MULTIPLE CKT 1	34.7/40	5.4	51/57	60/60
		7.2/9.6	1/60	2-4.8	MULTIPLE CKT 2	34.7/40	0	44/50	45/50
	RXBH-24A25J-B	18.0/24.0	1/60	6-4.0	SINGLE	86.6/100	5.4	115/132	125/150
		6.0/8.0	1/60	2-4.0	MULTIPLE CKT 1	28.9/33.4	5.4	43/49	45/50
		6.0/8.0	1/60	2-4.0	MULTIPLE CKT 2	28.9/33.4	0	37/42	40/45
		6.0/8.0	1/60	2-4.0	MULTIPLE CKT 3	28.9/33.4	0	37/42	40/45
	RXBH-24A30J-B	21.6/28.8	1/60	6-4.8	SINGLE	103.9/120	5.4	137/157	150/175
		7.2/9.6	1/60	2-4.8	MULTIPLE CKT 1	34.7/40	5.4	51/57	60/60
		7.2/9.6	1/60	2-4.8	MULTIPLE CKT 2	34.7/40	0	44/50	45/50
		7.2/9.6	1/60	2-4.8	MULTIPLE CKT 3	34.7/40	0	44/50	45/50
	RXBH-17A05C-B	3.6/4.8	3/60	1-4.8	SINGLE	10/11.6	5.4	20/22	20/25
	RXBH-24A05C-B	3.6/4.8	3/60	1-4.8	SINGLE	10/11.6	5.4	20/22	20/25
	RXBH-1724B05C-B	3.6/4.8	3/60	1-4.8	SINGLE	10/11.6	5.4	20/22	20/25
	RXBH-1724A07C-B	5.4/7.2	3/60	2-3.6	SINGLE	15/17.4	5.4	26/29	30/30
	RXBH-1724A10C-B	7.2/9.6	3/60	2-4.8	SINGLE	20/23.1	5.4	32/36	35/40
	RXBH-1724A13C-B	9.4/12.5	3/60	3-4.17	SINGLE	26.1/30.1	5.4	40/45	40/45
	RXBH-1724A15C-B	10.8/14.4	3/60	3-4.8	SINGLE	30/34.7	5.4	45/51	45/60
	RXBH-1724A18C-B	12.8/17.0	3/60	3-5.68	SINGLE	35.6/40.9	5.4	52/58	60/60
	RXBH-24A20C-B	14.4/19.2	3/60	4-4.8	SINGLE	40/46.2	5.4	57/65	60/70
	RXBH-1724A20J-B	7.2/9.6	3/60	2-4.8	MULTIPLE CKT 1	20/23.1	5.4	32/36	35/40
		7.2/9.6	3/60	2-4.8	MULTIPLE CKT 2	20/23.1	0	25/29	25/30
	RXBH-24A25C-B	18.0/24.0	3/60	6-4.0	SINGLE	50/57.7	5.4	70/79	70/80
	RXBH-1724A20J-B	9.0/12.0	3/60	3-4.0	MULTIPLE CKT 1	25/28.9	5.4	38/43	40/45
		9.0/12.0	3/60	3-4.0	MULTIPLE CKT 2	25/28.9	0	32/37	35/40
	RXBH-24A30C-B	21.6/28.8	3/60	6-4.8	SINGLE	60/69.3	5.4	82/94	90/100
	RXBH-1724A20J-B1	10.8/14.4	3/60	3-4.8	MULTIPLE CKT 1	30/34.7	5.4	45/51	45/60
		10.8/14.4	3/60	3-4.8	MULTIPLE CKT 2	30/34.7	0	38/44	40/45

? = A/B/C Heater Connection Types

A = Breaker

B = Terminal Block

C = Pullout Disconnect

[] Designates Metric Conversions

Electrical Data – With Electric Heat RH3V (Con't.)

Installation of the U.L. Listed original equipment manufacturer provided heater kits listed in the following table is recommended for all auxiliary heating requirements.

Air Handler Model	Heater Model Number	Heater kW (208/240V)	Ph/Hz	No. Elements – kW per	Type Supply Circuit Single Circuit Multiple Circuit	Heater Amps.	Blower Motor Amps	Minimum Circuit Ampacity	Maximum Overcurrent Protection
RH3VZ6024STACNJ	RXBH-1724?03J-B	2.3/3.0	1/60	1-3.0	SINGLE	11.1/12.5	5.2	21/23	25/25
	RXBH-1724?05J-B	3.6/4.8	1/60	1-4.8	SINGLE	17.4/20	5.2	29/32	30/35
	RXBH-1724?07J-B	5.4/7.2	1/60	2-3.6	SINGLE	26/30	5.2	39/44	40/45
	RXBH-1724?10J-B	7.2/9.6	1/60	2-4.8	SINGLE	34.7/40	5.2	50/57	50/60
	RXBH-1724A13J-B	9.4/12.5	1/60	3-4.17	SINGLE	45.2/52.1	5.2	63/72	70/80
	RXBH-1724A13J-B	3.1/4.2	1/60	1-4.17	MULTIPLE CKT 1	15/17.5	5.2	26/29	30/30
		6.3/8.3	1/60	2-4.17	MULTIPLE CKT 2	30.3/34.6	0	38/44	40/45
	RXBH-1724A15J-B	10.8/14.4	1/60	3-4.8	SINGLE	52/60	5.2	72/82	80/90
	RXBH-1724A15J-B	3.6/4.8	1/60	1-4.8	MULTIPLE CKT 1	17.4/20	5.2	29/32	30/35
		7.2/9.6	1/60	2-4.8	MULTIPLE CKT 2	34.7/40	0	44/50	45/50
	RXBH-1724A18J-B	12.8/17.0	1/60	3-5.68	SINGLE	61.6/70.9	5.2	84/96	90/100
	RXBJ-1724A18J-B	4.3/5.7	1/60	1-5.68	MULTIPLE CKT 1	20.7/23.8	5.2	33/37	35/40
		8.5/11.3	1/60	2-5.68	MULTIPLE CKT 2	40.9/47.1	0	52/59	60/60
	RXBH-24A20J-B	14.4/19.2	1/60	4-4.8	SINGLE	69.3/80	5.2	94/107	100/110
	RXBH-1724A20J-B	7.2/9.6	1/60	2-4.8	MULTIPLE CKT 1	34.7/40	5.2	50/57	50/60
		7.2/9.6	1/60	2-4.8	MULTIPLE CKT 2	34.7/40	0	44/50	45/50
	RXBH-24A25J-B	18.0/24.0	1/60	6-4.0	SINGLE	86.6/100	5.2	115/132	125/150
		6.0/8.0	1/60	2-4.0	MULTIPLE CKT 1	28.9/33.4	5.2	43/49	45/50
		6.0/8.0	1/60	2-4.0	MULTIPLE CKT 2	28.9/33.4	0	37/42	40/45
	RXBH-24A30J-B	6.0/8.0	1/60	2-4.0	MULTIPLE CKT 3	28.9/33.4	0	37/42	40/45
		21.6/28.8	1/60	6-4.8	SINGLE	103.9/120	5.2	137/157	150/175
		7.2/9.6	1/60	2-4.8	MULTIPLE CKT 1	34.7/40	5.2	50/57	50/60
	RXBH-1724A30J-B	7.2/9.6	1/60	2-4.8	MULTIPLE CKT 2	34.7/40	0	44/50	45/50
		7.2/9.6	1/60	2-4.8	MULTIPLE CKT 3	34.7/40	0	44/50	45/50
		7.2/9.6	1/60	2-4.8	MULTIPLE CKT 3	34.7/40	0	44/50	45/50
	RXBH-17A05C-B	3.6/4.8	3/60	1-4.8	SINGLE	10/11.6	5.2	19/21	20/25
	RXBH-24A05C-B	3.6/4.8	3/60	1-4.8	SINGLE	10/11.6	5.2	19/21	20/25
	RXBH-1724B05C-B	3.6/4.8	3/60	1-4.8	SINGLE	10/11.6	5.2	19/21	20/25
	RXBH-1724A07C-B	5.4/7.2	3/60	2-3.6	SINGLE	15/17.4	5.2	26/29	30/30
	RXBH-1724A10C-B	7.2/9.6	3/60	2-4.8	SINGLE	20/23.1	5.2	32/36	35/40
	RXBH-1724A13C-B	9.4/12.5	3/60	3-4.17	SINGLE	26.1/30.1	5.2	40/45	40/45
	RXBH-1724A15C-B	10.8/14.4	3/60	3-4.8	SINGLE	30/34.7	5.2	44/50	45/50
	RXBH-1724A18C-B	12.8/17.0	3/60	3-5.68	SINGLE	35.6/40.9	5.2	51/58	60/60
	RXBH-24A20C-B	14.4/19.2	3/60	4-4.8	SINGLE	40/46.2	5.2	57/65	60/70
	RXBH-1724A20J-B	7.2/9.6	3/60	2-4.8	MULTIPLE CKT 1	20/23.1	5.2	32/36	35/40
		7.2/9.6	3/60	2-4.8	MULTIPLE CKT 2	20/23.1	0	25/29	25/30
	RXBH-24A25C-B	18.0/24.0	3/60	6-4.0	SINGLE	50/57.7	5.2	69/79	70/80
	RXBH-1724A20J-B	9.0/12.0	3/60	3-4.0	MULTIPLE CKT 1	25/28.9	5.2	38/43	40/45
		9.0/12.0	3/60	3-4.0	MULTIPLE CKT 2	25/28.9	0	32/37	35/40
	RXBH-24A30C-B	21.6/28.8	3/60	6-4.8	SINGLE	60/69.3	5.2	82/94	90/100
RXBH-1724A20J-B	10.8/14.4	3/60	3-4.8	MULTIPLE CKT 1	30/34.7	5.2	44/50	45/50	
	10.8/14.4	3/60	3-4.8	MULTIPLE CKT 2	30/34.7	0	38/44	40/45	

? = A/B/C Heater Connection Types

A = Breaker

B = Terminal Block

C = Pullout Disconnect

[] Designates Metric Conversions

Electrical Wiring

Power Wiring

- Field wiring must comply with the National Electrical Code (C.E.C. in Canada) and any applicable local ordinance.
- Supply wiring must be 75°C minimum copper conductors only.
- See electrical data for product Ampacity rating and Circuit Protector requirement.

Accessories

• Combustible Floor Base RXHB-

Model Cabinet Size	Combustible Floor Base Model Number
17	RXHB-17
21	RXHB-21
24	RXHB-24

- **Jumper Bar Kit 3 Ckt. to 1 Ckt. RXBJ-A31** is used to convert single phase multiple three circuit units to a single supply circuit. Kit includes cover and screw for line side terminals.
- **Jumper Bar Kit 2 Ckt. to 1 Ckt. RXBJ-A21** is used to convert single phase multiple two circuit units to a single supply circuit. Kit includes cover and screw for line side terminals.
- **Note:** No jumper bar kit is available to convert three phase multiple two circuit units to a single supply circuit.

• Auxiliary Horizontal Overflow Pan Accessory RXBM-

Nominal Cooling Capacity-Tons	Auxiliary Horizontal Overflow Pan Accessory Model Number
2 - 3	RXBM-AC48
4 - 5	RXBM-AC61

• Supply and Return Air Sensor Kit RXHT-A02

The RXHT-A02 Thermistor Kit is to be used with the air handler control to monitor the system return and leaving air temperatures. These temperatures can be monitored with the EcoNet® communicating thermostat.

Grounding

- This product must be sufficiently grounded in accordance with National Electrical Code (C.E.C. in Canada) and any applicable local ordinance.
- A grounding lug is provided.

• Auxiliary Electric Heater Kits RXBH-

Heater Kits include circuit breakers which meet UL and cUL requirements for service disconnect. See the Electric Heat Electrical Data in this specification sheet for specific Heater Kit Model numbers.

• Horizontal Adapter Kit RXHH-

This horizontal adapter kit is used to convert Upflow/Downflow only models to horizontal flow. See the following table to order proper horizontal adapter kit.

Coil Model	Horizontal Adapter Kit Model Number (Single Qty.)	Horizontal Adapter Kit Model Number (10-Pack Qty.)
2414	RXHH-A01	RXHH-A01 x 10
2417	RXHH-A02	RXHH-A02 x 10
2421/3617/3621	RXHH-A03	RXHH-A03 x 10
4821/4824/6021	RXHH-A06	RXHH-A06 x 10
6024	RXHH-A05	RXHH-A05 x 10

• External Filter Base RXHF-

Model Cabinet Size	Filter Size In. [mm]	Part Number*	A	B
17	16 x 20 [406 x 508]	RXHF-17	15.70	17.5
21	20 x 20 [508 x 508]	RXHF-21	19.20	21.0
24	25 x 20 [635 x 508]	RXHF-24	22.70	25.5

*Accommodates 1" or 2" filter

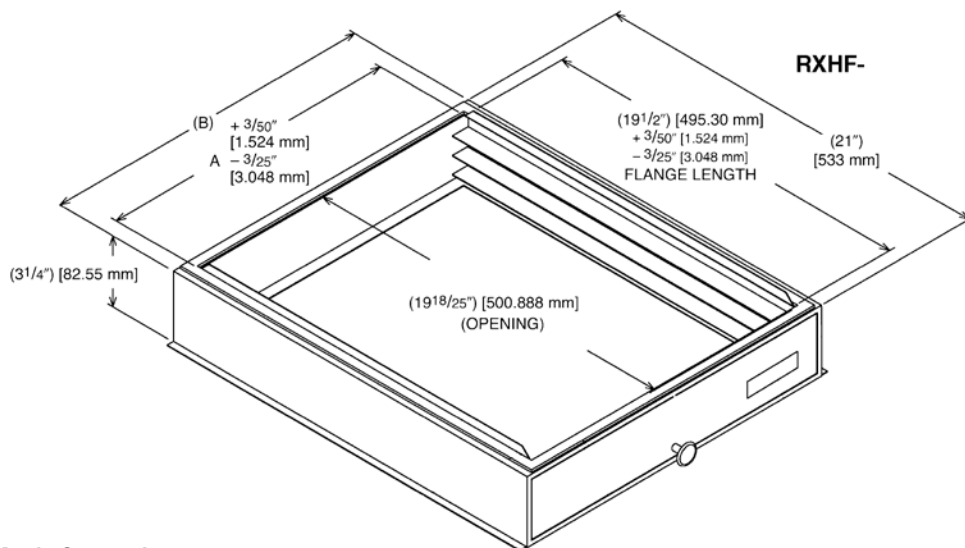

[] Designates Metric Conversions



The new degree of comfort.®

Endeavor™ Line Air Handlers



RHMVZ

Motor: Constant CFM

Airflow Stages: Modulating

Expansion Device: Electronic Expansion Valve (EEV)

Efficiencies: 18+ SEER2



The Bluetooth® word mark and logos are registered trademarks owned by Bluetooth SIG, Inc. and any use of such marks by Rheem® is under license. Other trademarks and trade names are those of their respective owners.

Table of Contents

Features & Benefits	3
Model Number Identification	4
Dimensional Data	5-7
Airflow Directional Data	8
Airflow Performance Data	9
Electrical Data	10-15
Limited Warranty	16

Features and Benefits

- **Constant CFM Motor¹:** Truly variable speed technology allows for ultimate humidity control, quieter sound levels and contributes to year-round energy savings
- **Quietest Operation¹:** Provided by Modulating operation and truly variable speed airflow technology and sturdy cabinet construction with 1.0 inch of foil faced insulation for some of the quietest sound characteristics
- **PlusOne[®] Diagnostics:** With the Rheem Contractor & EcoNet[®] Apps, built-in EcoNet[®] & Bluetooth² technology makes monitoring, troubleshooting and repairing the product easier than ever before
- **Dip Switch Free Installation Commissioning via Bluetooth Technology:** Seamless final install step without DIP switch configuration using the Rheem Contractor App.
- **EcoNet[®] Enabled Air Handler:**
 - The latest in sensor technology and the EcoNet[®] monitoring system provides a new level of protection, control and energy savings
 - Allows on-the-go control and receipt of system alerts by the homeowner via the EcoNet[®] Smart Thermostat and EcoNet[®] App³
- **Aluminum Indoor Coil Design:** Are constructed of aluminum fins bonded to internally grooved aluminum tubing and are more corrosion resistant
- **Versatile 4-Way Convertible Compact Design:** Allows for upflow, downflow, horizontal left and horizontal right applications, even in the smallest of spaces
- **Rugged Steel, Compact Cabinet Construction:** Designed for added strength and versatility
- **Field-installed Auxiliary Heater Kits:** Provide exact heat for indoor comfort and include circuit breakers which meet UL and cUL requirements for service disconnect
- **Less than 2% Cabinet Air Leakage at 1-inch H₂O:** When tested in accordance with AHRAE Standard 193

¹Based on manufacturer's air handler offering, and the product's airflow stages, motor type and cabinet insulation. Sound levels are also dependent on air handler location and installation.

²The Bluetooth[®] word mark and logos are registered trademarks owned by Bluetooth SIG, Inc. and any use of such marks by Rheem[®] is under license. Other trademarks and trade names are those of their respective owners.

³WIFI broadband internet connection required. Download the EcoNet[®] App from the App Store[®] or Google Play[®] to set up your EcoNet[®] Smart Thermostat. Receipt of notifications depend on home WIFI set up. Amazon, Alexa and all related logos are trademarked of Amazon.com, Inc. or its affiliates.

Air Handlers

<u>R</u>	<u>H</u>	<u>M</u>	<u>V</u>	<u>Z</u>	<u>24</u>	<u>17</u>	<u>S</u>	<u>E</u>	<u>A</u>	<u>C</u>	<u>N</u>	<u>A</u>
Brand		Stages Of Airflow	Motor Type	Refrigerant	Capacity	Width	Efficiency	Metering	Major Series	Controls	Coil Series	Voltage
R - Rheem	H - Multipoise Air Handler	M - Modulating	V - Constant CFM	Z - R-410A	24 - 2.0T 30 - 2.5T 36 - 3.0T 48 - 4.0T 60 - 5.0T	17 - 17.5" 21 - 21" 24 - 24.5"	S - Standard	E - EEV	A - 1st Design	C - Communicating U - Other Communicating	A - A Coil N - N Coil	J - 208-240/1/60

Available Models
RHMVZ2417SEACNJ
RHMVZ2421HEACNJ
RHMVZ2421MEACNJ
RHMVZ2421HEACAJ
RHMVZ6021SEACAJ
RHMVZ6024SEACNJ

Standard Equipment
Compact unit design - all standard heat air handler models are only 42-1/2 to 57 inches [1079 to 1448 mm] high
Attractive pre-painted cabinet exterior
Rugged wall steel cabinet construction
1.0" foil faced insulation for excellent thermal and sound performance
Four leg blower motor mount
Blower housing with controls, motor and blower.
Slide-out blower design for service & maintenance convenience
Traditional open wire element design for heat applications
Field convertible for vertical, downflow, horizontal left hand or right hand air supply
Indoor coil desing provideds low air side pressure drop, high performance and compact size
Coils constructed of aluminum fins bonded to internally grooved aluminum tubing
Coils are tested at the factory with an extensive refrigerant leak check
Coils have copper sweat refrigerant connections
Coils utilize chatleff metering device connections
Molded poymer corrosion resistant condensate drain pan on all indoor coils
Supply duct flanges
Provisions for field electrical, connections available form either side of top of cabinet
Connection point for high and low voltage wiring
Concentric knockouts are provided for power connection

[] Designates Metric Conversions

Unit Dimensions

Return Air Opening Dimensions

Model Cabinet Size	Return Air Opening Width (Inches)	Return Air Opening Depth/Length (Inches)
17	15 ⁷ / ₈	19 ³ / ₄
21	19 ³ / ₈	19 ³ / ₄
24	22 ⁷ / ₈	19 ³ / ₄

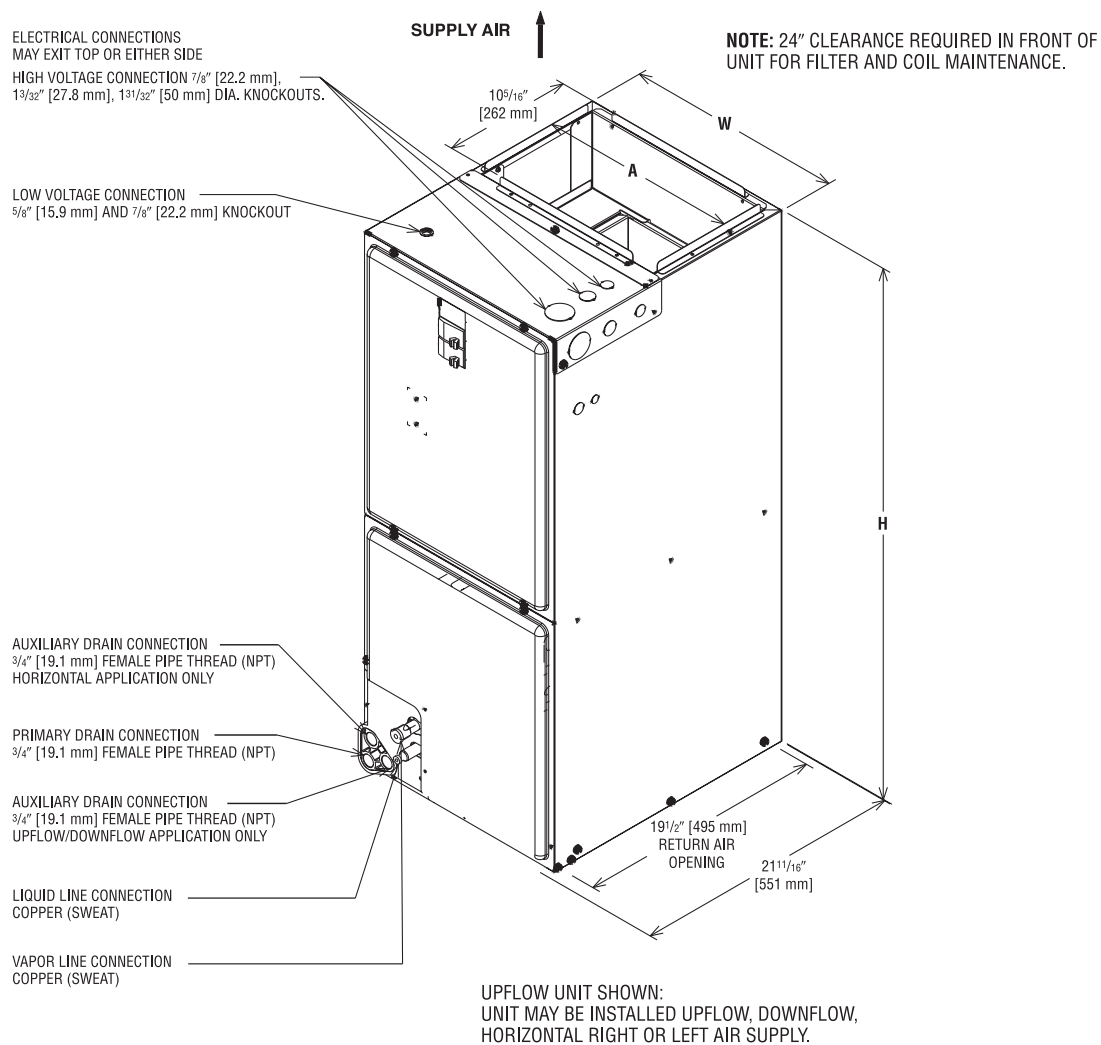

[] Designates Metric Conversions

FIGURE 6
VERTICAL DOWNFLOW & HORIZONTAL RIGHT APPLICATION

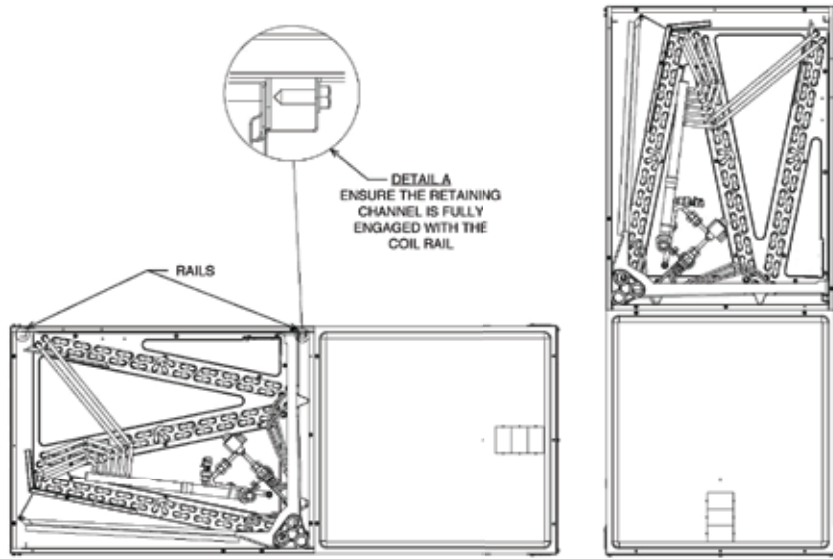
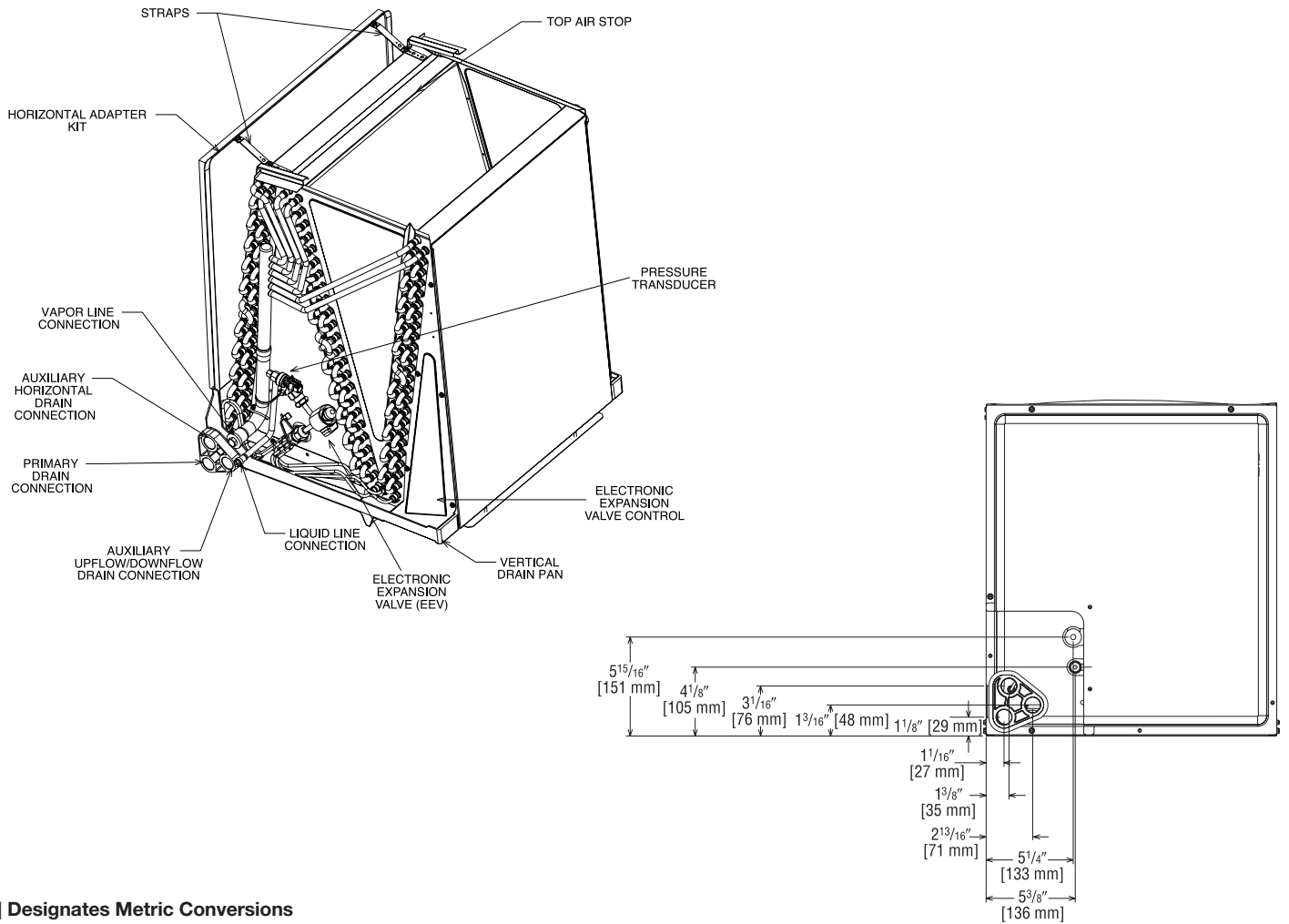

FIGURE 7
INDOOR COIL AND DRAIN PAN SET-UP



[] Designates Metric Conversions

Unit Dimensions

Return Air Opening Dimensions

Model Cabinet Size	Return Air Opening Width (Inches)	Return Air Opening Depth/Length (Inches)
17	15 ⁷ / ₈	19 ³ / ₄
21	19 ³ / ₈	19 ³ / ₄
24	22 ⁷ / ₈	19 ³ / ₄

[] Designates Metric Conversions

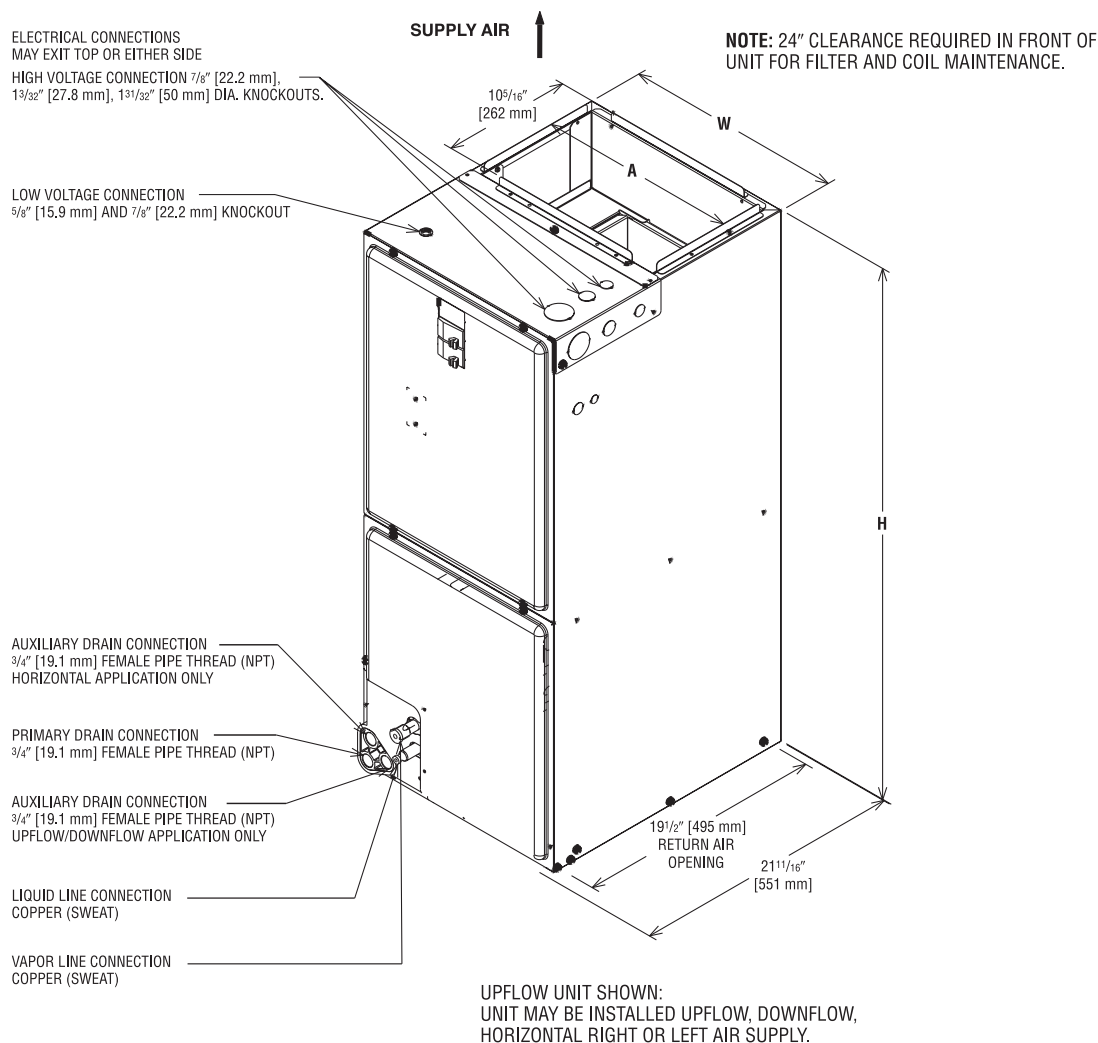

Unit Dimensions & Weights

Model Size RHMVZ	Refrigerant Connections Sweat (In.) [mm] ID		Unit Width "W" In. [mm]	Unit Height "H" In. [mm]	Supply Duct "A" In. [mm]	Unit Weight/ Shipping Weight (Lbs.) [kg]
	Liquid	Vapor				
2417SEACN	3/8 [9.53]	3/4 [19.05]	17 ¹ / ₂ [445]	42 ¹ / ₂ [1080]	16 [406]	91/105 [41/48]
2421MEACN	3/8 [9.53]	3/4 [19.05]	21 [533]	42 ¹ / ₂ [1080]	19 ¹ / ₂ [495]	103/118 [47/54]
2421HEACN	3/8 [9.53]	7/8 [22.23]	21 [533]	50 ¹ / ₂ [1282]	19 ¹ / ₂ [495]	123/139 [56/63]
2421HEACA	3/8 [9.53]	7/8 [22.23]	21 [533]	57 [1448]	19 ¹ / ₂ [495]	140/152 [64/69]
6021SEACA	3/8 [9.53]	7/8 [22.23]	21 [533]	57 [1448]	19 ¹ / ₂ [495]	140/152 [64/69]
6024SEACN	3/8 [9.53]	7/8 [22.23]	24 ¹ / ₂ [622]	55 ¹ / ₂ [1410]	23 [584]	159/176 [72/80]

Airflow Directional Data

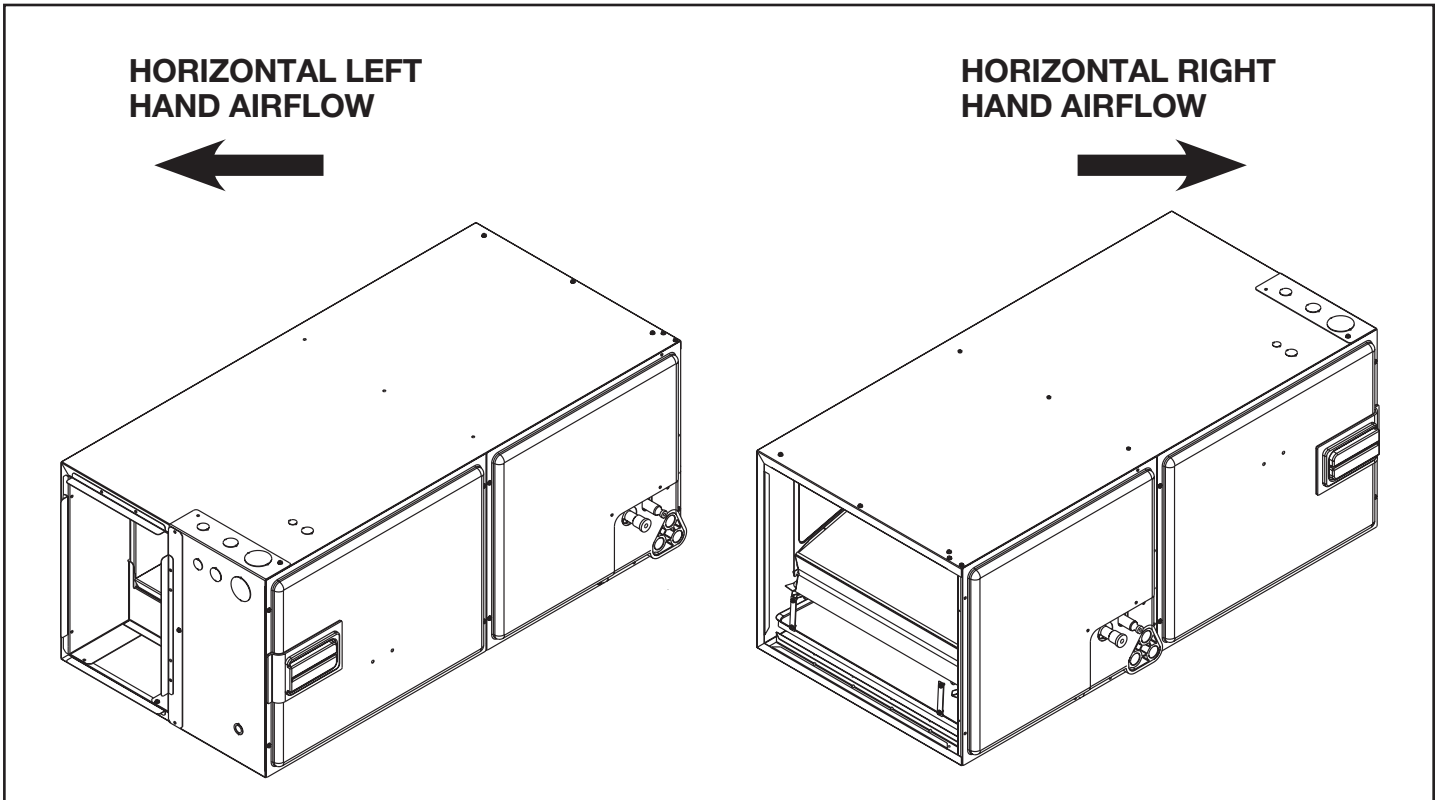
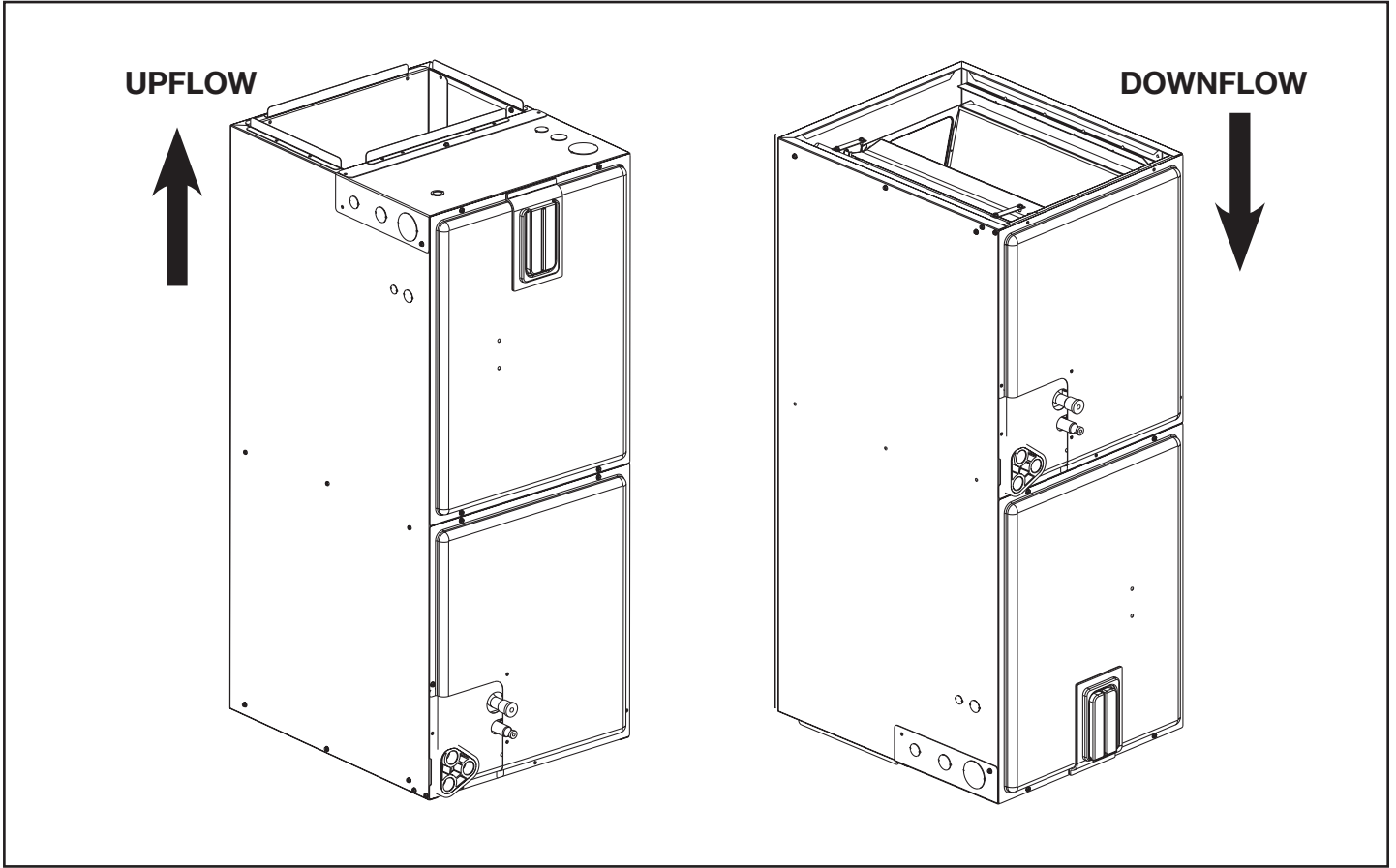

Airflow Performance

Airflow performance data is based on cooling performance with a coil and no filter in place. Select performance table for appropriate unit size, voltage and number of electric heaters to be used. Make sure external static applied to unit allows operation within the minimum and maximum limits shown in

table below for both cooling and electric heat operation. For optimum blower performance, operate the unit in the .3 [8 mm] to .7 inches [18 mm] W.C. external static range. Units with coils should be applied with a minimum of .1 inch [3 mm] W.C. external static range.

Airflow Operating Limits

Rated Airflow for RHMVZ Air-Handlers + RA18 Condensing Units & RP18 Heat Pumps					
Air Handler Model	Outdoor Model	RHMVZ Air-Flow (EcoNet®)			
		Cooling Mode CFM [L/s]		Heating Mode CFM [L/s]	
		Minimum	Maximum	Minimum	Maximum
RHMVZ2417SEACN	RA18AZ24	310 [146]	840 [396]	—	—
RHMVZ2421MEACN	RA18AZ24	310 [146]	840 [396]	—	—
RHMVZ2421HEACN	RA18AZ24	310 [146]	840 [396]	—	—
RHMVZ2421HEACA	RP18AZ24	500 [236]	800 [378]	600 [283]	800 [378]
RHMVZ6021SEACA	RA18AZ36	580 [274]	1210 [571]	—	—
	RA18AZ48	475 [224]	1565 [739]	—	—
	RA18AZ60	516 [244]	1725 [814]	—	—
	RP18AZ36	516 [244]	1200 [566]	960 [453]	1300 [614]
	RP18AZ48	550 [260]	1600 [755]	950 [448]	1500 [708]
RHMVZ6024SEACN	RP18AZ60	1100 [519]	1700 [802]	1100 [519]	1800 [850]
	RA18AZ36	580 [274]	1210 [571]	—	—
	RA18AZ48	475 [224]	1565 [739]	—	—
	RA18AZ60	516 [244]	1725 [814]	—	—

[] Designates Metric Conversions

Electrical Data – Blower Motor Only – No Electric Heat RHMVZ

Model RHMVZ	Voltage	Phase*	Hertz	HP [W]	RPM	Motor Amps.	Minimum Circuit Ampacity	Maximum Overcurrent Protection
2417SEACN	208/240	1	60	1/3	300-1300	2.8	4	15
2421MEACN		1		1/3		2.7	4	15
2421HEACN		1		1/2		3.5	5	15
2421HEACA		1		3/4		5.7	8	15
6021SEACA		1		3/4		5.7	8	15
6024SEACN		1		3/4		5.2	7	15

Electrical Data – With Electric Heat RHMVZ

Air Handler Model	Heater Model Number	Heater kW (208/240V)	Ph/Hz	No. Elements - kW per	Type Supply Circuit Single Circuit Multiple Circuit	Heater Circuit Amps	Tested Blower Motor Amps	Minimum Circuit Ampacity	Maximum Overcurrent Protection
RHMVZ2417SEACNJ	RXBH-1724?03J-B	2.3/3.0	1/60	1-3.0	SINGLE	11.1/12.5	2.8	18/20	20/20
	RXBH-1724?05J-B	3.6/4.8	1/60	1-4.8	SINGLE	17.4/20	2.8	26/29	30/30
	RXBH-1724?07J-B	5.4/7.2	1/60	2-3.6	SINGLE	26/30	2.8	36/41	40/45
	RXBH-1724?10J-B	7.2/9.6	1/60	2-4.8	SINGLE	34.7/40	2.8	47/54	50/60
	RXBH-1724A13J-B	9.4/12.5	1/60	3-4.17	SINGLE	45.2/52.1	2.8	60/69	60/70
		3.1/4.2	1/60	1-4.17	MULTIPLE CKT 1	15/17.5	2.8	23/26	25/30
		6.3/8.3	1/60	2-4.17	MULTIPLE CKT 2	30.3/34.6	0	38/44	40/45
	RXBH-17A05C-B	3.6/4.8	3/60	1-4.8	SINGLE	10/11.6	2.8	16/18	20/20
	RXBH-24A05C-B	3.6/4.8	3/60	1-4.8	SINGLE	10/11.6	2.8	16/18	20/20
	RXBH-1724B05C-B	3.6/4.8	3/60	1-4.8	SINGLE	10/11.6	2.8	16/18	20/20
	RXBH-1724A07C-B	5.4/7.2	3/60	2-3.6	SINGLE	15/17.4	2.8	23/26	25/30
	RXBH-1724A10C-B	7.2/9.6	3/60	2-4.8	SINGLE	20/23.1	2.8	29/33	30/35
RXBH-1724A13C-B	9.4/12.5	3/60	3-4.17	SINGLE	26.1/30.1	2.8	37/42	40/45	
RHMVZ2421MEACNJ	RXBH-1724?03J-B	2.3/3.0	1/60	1-3.0	SINGLE	11.1/12.5	2.7	18/19	20/20
	RXBH-1724?05J-B	3.6/4.8	1/60	1-4.8	SINGLE	17.4/20	2.7	26/29	30/30
	RXBH-1724?07J-B	5.4/7.2	1/60	2-3.6	SINGLE	26/30	2.7	36/41	40/45
	RXBH-1724?10J-B	7.2/9.6	1/60	2-4.8	SINGLE	34.7/40	2.7	47/54	50/60
	RXBH-1724A13J-B	9.4/12.5	1/60	3-4.17	SINGLE	45.2/52.1	2.7	60/69	60/70
		3.1/4.2	1/60	1-4.17	MULTIPLE CKT 1	15/17.5	2.7	23/26	25/30
		6.3/8.3	1/60	2-4.17	MULTIPLE CKT 2	30.3/34.6	0	38/44	40/45
	RXBH-17A05C-B	3.6/4.8	3/60	1-4.8	SINGLE	10/11.6	2.7	16/18	20/20
	RXBH-24A05C-B	3.6/4.8	3/60	1-4.8	SINGLE	10/11.6	2.7	16/18	20/20
	RXBH-1724B05C-B	3.6/4.8	3/60	1-4.8	SINGLE	10/11.6	2.7	16/18	20/20
	RXBH-1724A07C-B	5.4/7.2	3/60	2-3.6	SINGLE	15/17.4	2.7	23/26	25/30
	RXBH-1724A10C-B	7.2/9.6	3/60	2-4.8	SINGLE	20/23.1	2.7	29/33	30/35
RXBH-1724A13C-B	9.4/12.5	3/60	3-4.17	SINGLE	26.1/30.1	2.7	36/41	40/45	

Electrical Data – With Electric Heat RHMVZ (Con't.)

Air Handler Model	Heater Model Number	Heater kW (208/240V)	Ph/Hz	No. Elements - kW per	Type Supply Circuit Single Circuit Multiple Circuit	Heater Circuit Amps	Tested Blower Motor Amps	Minimum Circuit Ampacity	Maximum Overcurrent Protection
RHMVZ2421HEACNJ	RXBH-1724?03J-B	2.3/3.0	1/60	1-3.0	SINGLE	11.1/12.5	3.5	19/20	20/20
	RXBH-1724?05J-B	3.6/4.8	1/60	1-4.8	SINGLE	17.4/20	3.5	27/30	30/30
	RXBH-1724?07J-B	5.4/7.2	1/60	2-3.6	SINGLE	26/30	3.5	37/42	40/45
	RXBH-1724?10J-B	7.2/9.6	1/60	2-4.8	SINGLE	34.7/40	3.5	48/55	50/60
	RXBH-1724A13J-B	9.4/12.5	1/60	3-4.17	SINGLE	45.2/52.1	3.5	61/70	70/70
		3.1/4.2	1/60	1-4.17	MULTIPLE CKT 1	15/17.5	3.5	24/27	25/30
		6.3/8.3	1/60	2-4.17	MULTIPLE CKT 2	30.3/34.6	0	38/44	40/45
	RXBH-17A05C-B	3.6/4.8	3/60	1-4.8	SINGLE	10/11.6	3.5	17/19	20/20
	RXBH-24A05C-B	3.6/4.8	3/60	1-4.8	SINGLE	10/11.6	3.5	17/19	20/20
	RXBH-1724B05C-B	3.6/4.8	3/60	1-4.8	SINGLE	10/11.6	3.5	17/19	20/20
	RXBH-1724A07C-B	5.4/7.2	3/60	2-3.6	SINGLE	15/17.4	3.5	24/27	25/30
	RXBH-1724A10C-B	7.2/9.6	3/60	2-4.8	SINGLE	20/23.1	3.5	30/34	30/35
RXBH-1724A13C-B	9.4/12.5	3/60	3-4.17	SINGLE	26.1/30.1	3.5	37/42	40/45	
RHMVZ2421HEACAJ	RXBH-1724?03J-B	2.3/3.0	1/60	1-3.0	SINGLE	11.1/12.5	5.7	21/23	25/25
	RXBH-1724?05J-B	3.6/4.8	1/60	1-4.8	SINGLE	17.4/20	5.7	29/33	30/35
	RXBH-1724?07J-B	5.4/7.2	1/60	2-3.6	SINGLE	26/30	5.7	40/45	40/45
	RXBH-1724?10J-B	7.2/9.6	1/60	2-4.8	SINGLE	34.7/40	5.7	51/58	60/60
	RXBH-1724A13J-B	9.4/12.5	1/60	3-4.17	SINGLE	45.2/52.1	5.7	64/73	70/80
		3.1/4.2	1/60	1-4.17	MULTIPLE CKT 1	15/17.5	5.7	26/29	30/30
		6.3/8.3	1/60	2-4.17	MULTIPLE CKT 2	30.3/34.6	0	38/44	40/45
	RXBH-17A05C-B	3.6/4.8	3/60	1-4.8	SINGLE	10/11.6	5.7	20/22	20/25
	RXBH-24A05C-B	3.6/4.8	3/60	1-4.8	SINGLE	10/11.6	5.7	20/22	20/25
	RXBH-1724B05C-B	3.6/4.8	3/60	1-4.8	SINGLE	10/11.6	5.7	20/22	20/25
	RXBH-1724A07C-B	5.4/7.2	3/60	2-3.6	SINGLE	15/17.4	5.7	26/29	30/30
	RXBH-1724A10C-B	7.2/9.6	3/60	2-4.8	SINGLE	20/23.1	5.7	33/36	35/40
RXBH-1724A13C-B	9.4/12.5	3/60	3-4.17	SINGLE	26.1/30.1	5.7	40/45	40/45	

Electrical Data – With Electric Heat RHMVZ (Con't.)

Air Handler Model	Heater Model Number	Heater kW (208/240V)	Ph/Hz	No. Elements - kW per	Type Supply Circuit Single Circuit Multiple Circuit	Heater Circuit Amps	Tested Blower Motor Amps	Minimum Circuit Ampacity	Maximum Overcurrent Protection
RHMVZ6021SEACAJ	RXBH-1724?03J-B	2.3/3.0	1/60	1-3.0	SINGLE	11.1/12.5	5.7	21/23	25/25
	RXBH-1724?05J-B	3.6/4.8	1/60	1-4.8	SINGLE	17.4/20	5.7	29/33	30/35
	RXBH-1724?07J-B	5.4/7.2	1/60	2-3.6	SINGLE	26/30	5.7	40/45	40/45
	RXBH-1724?10J-B	7.2/9.6	1/60	2-4.8	SINGLE	34.7/40	5.7	51/58	60/60
	RXBH-1724A13J-B	9.4/12.5	1/60	3-4.17	SINGLE	45.2/52.1	5.7	64/73	70/80
		3.1/4.2	1/60	1-4.17	MULTIPLE CKT 1	15/17.5	5.7	26/29	30/30
		6.3/8.3	1/60	2-4.17	MULTIPLE CKT 2	30.3/34.6	0	38/44	40/45
	RXBH-1724A15J-B	10.8/14.4	1/60	3-4.8	SINGLE	52/60	5.7	73/83	80/90
	RXBH-1724A15J-B	3.6/4.8	1/60	1-4.8	MULTIPLE CKT 1	17.4/20	5.7	29/33	30/35
		7.2/9.6	1/60	2-4.8	MULTIPLE CKT 2	34.7/40	0	44/50	45/50
	RXBH-1724A18J-B	12.8/17.0	1/60	3-5.68	SINGLE	61.6/70.9	5.7	85/96	90/100
	RXBJ-1724A18J-B	4.3/5.7	1/60	1-5.68	MULTIPLE CKT 1	20.7/23.8	5.7	33/37	35/40
		8.5/11.3	1/60	2-5.68	MULTIPLE CKT 2	40.9/47.1	0	52/59	60/60
	RXBH-24A20J-B	14.4/19.2	1/60	4-4.8	SINGLE	69.3/80	5.7	94/108	100/110
	RXBH-1724A20J-B	7.2/9.6	1/60	2-4.8	MULTIPLE CKT 1	34.7/40	5.7	51/58	60/60
		7.2/9.6	1/60	2-4.8	MULTIPLE CKT 2	34.7/40	0	44/50	45/50
	RXBH-24A25J-B	18.0/24.0	1/60	6-4.0	SINGLE	86.6/100	5.7	116/133	125/150
		6.0/8.0	1/60	2-4.0	MULTIPLE CKT 1	28.9/33.4	5.7	44/49	45/50
		6.0/8.0	1/60	2-4.0	MULTIPLE CKT 2	28.9/33.4	0	37/42	40/45
		6.0/8.0	1/60	2-4.0	MULTIPLE CKT 3	28.9/33.4	0	37/42	40/45
	RXBH-24A30J-B	21.6/28.8	1/60	6-4.8	SINGLE	103.9/120	5.7	137/158	150/175
	RXBH-1724A30J-B	7.2/9.6	1/60	2-4.8	MULTIPLE CKT 1	34.7/40	5.7	51/58	60/60
		7.2/9.6	1/60	2-4.8	MULTIPLE CKT 2	34.7/40	0	44/50	45/50
		7.2/9.6	1/60	2-4.8	MULTIPLE CKT 3	34.7/40	0	44/50	45/50
	RXBH-17A05C-B	3.6/4.8	3/60	1-4.8	SINGLE	10/11.6	5.7	20/22	20/25
	RXBH-24A05C-B	3.6/4.8	3/60	1-4.8	SINGLE	10/11.6	5.7	20/22	20/25
	RXBH-1724B05C-B	3.6/4.8	3/60	1-4.8	SINGLE	10/11.6	5.7	20/22	20/25
	RXBH-1724A07C-B	5.4/7.2	3/60	2-3.6	SINGLE	15/17.4	5.7	26/29	30/30
	RXBH-1724A10C-B	7.2/9.6	3/60	2-4.8	SINGLE	20/23.1	5.7	33/36	35/40
	RXBH-1724A13C-B	9.4/12.5	3/60	3-4.17	SINGLE	26.1/30.1	5.7	40/45	40/45
	RXBH-1724A15C-B	10.8/14.4	3/60	3-4.8	SINGLE	30/34.7	5.7	45/51	45/60
	RXBH-1724A18C-B	12.8/17.0	3/60	3-5.68	SINGLE	35.6/40.9	5.7	52/59	60/60
	RXBH-24A20C-B	14.4/19.2	3/60	4-4.8	SINGLE	40/46.2	5.7	58/65	60/70
	RXBH-1724A20J-B	7.2/9.6	3/60	2-4.8	MULTIPLE CKT 1	20/23.1	5.7	33/36	35/40
		7.2/9.6	3/60	2-4.8	MULTIPLE CKT 2	20/23.1	0	25/29	25/30
	RXBH-24A25C-B	18.0/24.0	3/60	6-4.0	SINGLE	50/57.7	5.7	70/80	70/80
	RXBH-1724A20J-B	9.0/12.0	3/60	3-4.0	MULTIPLE CKT 1	25/28.9	5.7	39/44	40/45
		9.0/12.0	3/60	3-4.0	MULTIPLE CKT 2	25/28.9	0	32/37	35/40
	RXBH-24A30C-B	21.6/28.8	3/60	6-4.8	SINGLE	60/69.3	5.7	83/94	90/100
	RXBH-1724A20J-B	10.8/14.4	3/60	3-4.8	MULTIPLE CKT 1	30/34.7	5.7	45/51	45/60
10.8/14.4		3/60	3-4.8	MULTIPLE CKT 2	30/34.7	0	38/44	40/45	

Electrical Data – With Electric Heat RHMVZ (Con't.)

Air Handler Model	Heater Model Number	Heater kW (208/240V)	Ph/Hz	No. Elements - kW per	Type Supply Circuit Single Circuit Multiple Circuit	Heater Circuit Amps	Tested Blower Motor Amps	Minimum Circuit Ampacity	Maximum Overcurrent Protection
RHMVZ6024SEACNJ	RXBH-1724?03J-B	2.3/3.0	1/60	1-3.0	SINGLE	11.1/12.5	5.2	21/23	25/25
	RXBH-1724?05J-B	3.6/4.8	1/60	1-4.8	SINGLE	17.4/20	5.2	29/32	30/35
	RXBH-1724?07J-B	5.4/7.2	1/60	2-3.6	SINGLE	26/30	5.2	39/44	40/45
	RXBH-1724?10J-B	7.2/9.6	1/60	2-4.8	SINGLE	34.7/40	5.2	50/57	50/60
	RXBH-1724A13J-B	9.4/12.5	1/60	3-4.17	SINGLE	45.2/52.1	5.2	63/72	70/80
	RXBH-1724A13J-B	3.1/4.2	1/60	1-4.17	MULTIPLE CKT 1	15/17.5	5.2	26/29	30/30
		6.3/8.3	1/60	2-4.17	MULTIPLE CKT 2	30.3/34.6	0	38/44	40/45
	RXBH-1724A15J-B	10.8/14.4	1/60	3-4.8	SINGLE	52/60	5.2	72/82	80/90
	RXBH-1724A15J-B	3.6/4.8	1/60	1-4.8	MULTIPLE CKT 1	17.4/20	5.2	29/32	30/35
		7.2/9.6	1/60	2-4.8	MULTIPLE CKT 2	34.7/40	0	44/50	45/50
	RXBH-1724A18J-B	12.8/17.0	1/60	3-5.68	SINGLE	61.6/70.9	5.2	84/96	90/100
	RXBJ-1724A18J-B	4.3/5.7	1/60	1-5.68	MULTIPLE CKT 1	20.7/23.8	5.2	33/37	35/40
		8.5/11.3	1/60	2-5.68	MULTIPLE CKT 2	40.9/47.1	0	52/59	60/60
	RXBH-24A20J-B	14.4/19.2	1/60	4-4.8	SINGLE	69.3/80	5.2	94/107	100/110
	RXBH-1724A20J-B	7.2/9.6	1/60	2-4.8	MULTIPLE CKT 1	34.7/40	5.2	50/57	50/60
		7.2/9.6	1/60	2-4.8	MULTIPLE CKT 2	34.7/40	0	44/50	45/50
	RXBH-24A25J-B	18.0/24.0	1/60	6-4.0	SINGLE	86.6/100	5.2	115/132	125/150
		6.0/8.0	1/60	2-4.0	MULTIPLE CKT 1	28.9/33.4	5.2	43/49	45/50
		6.0/8.0	1/60	2-4.0	MULTIPLE CKT 2	28.9/33.4	0	37/42	40/45
		6.0/8.0	1/60	2-4.0	MULTIPLE CKT 3	28.9/33.4	0	37/42	40/45
	RXBH-24A30J-B	21.6/28.8	1/60	6-4.8	SINGLE	103.9/120	5.2	137/157	150/175
	RXBH-1724A30J-B	7.2/9.6	1/60	2-4.8	MULTIPLE CKT 1	34.7/40	5.2	50/57	50/60
		7.2/9.6	1/60	2-4.8	MULTIPLE CKT 2	34.7/40	0	44/50	45/50
		7.2/9.6	1/60	2-4.8	MULTIPLE CKT 3	34.7/40	0	44/50	45/50
	RXBH-17A05C-B	3.6/4.8	3/60	1-4.8	SINGLE	10/11.6	5.2	19/21	20/25
	RXBH-24A05C-B	3.6/4.8	3/60	1-4.8	SINGLE	10/11.6	5.2	19/21	20/25
	RXBH-1724B05C-B	3.6/4.8	3/60	1-4.8	SINGLE	10/11.6	5.2	19/21	20/25
	RXBH-1724A07C-B	5.4/7.2	3/60	2-3.6	SINGLE	15/17.4	5.2	26/29	30/30
	RXBH-1724A10C-B	7.2/9.6	3/60	2-4.8	SINGLE	20/23.1	5.2	32/36	35/40
	RXBH-1724A13C-B	9.4/12.5	3/60	3-4.17	SINGLE	26.1/30.1	5.2	40/45	40/45
	RXBH-1724A15C-B	10.8/14.4	3/60	3-4.8	SINGLE	30/34.7	5.2	44/50	45/50
	RXBH-1724A18C-B	12.8/17.0	3/60	3-5.68	SINGLE	35.6/40.9	5.2	51/58	60/60
	RXBH-24A20C-B	14.4/19.2	3/60	4-4.8	SINGLE	40/46.2	5.2	57/65	60/70
	RXBH-1724A20J-B	7.2/9.6	3/60	2-4.8	MULTIPLE CKT 1	20/23.1	5.2	32/36	35/40
		7.2/9.6	3/60	2-4.8	MULTIPLE CKT 2	20/23.1	0	25/29	25/30
	RXBH-24A25C-B	18.0/24.0	3/60	6-4.0	SINGLE	50/57.7	5.2	69/79	70/80
	RXBH-1724A20J-B	9.0/12.0	3/60	3-4.0	MULTIPLE CKT 1	25/28.9	5.2	38/43	40/45
		9.0/12.0	3/60	3-4.0	MULTIPLE CKT 2	25/28.9	0	32/37	35/40
	RXBH-24A30C-B	21.6/28.8	3/60	6-4.8	SINGLE	60/69.3	5.2	82/94	90/100
	RXBH-1724A20J-B	10.8/14.4	3/60	3-4.8	MULTIPLE CKT 1	30/34.7	5.2	44/50	45/50
		10.8/14.4	3/60	3-4.8	MULTIPLE CKT 2	30/34.7	0	38/44	40/45

Electrical Wiring

Power Wiring

- Field wiring must comply with the National Electrical Code (C.E.C. in Canada) and any applicable local ordinance.
- Supply wiring must be 75°C minimum copper conductors only.
- See electrical data for product Ampacity rating and Circuit Protector requirement.

Accessories

• Combustible Floor Base RXHB-

Model Cabinet Size	Combustible Floor Base Model Number
17	RXHB-17
21	RXHB-21
24	RXHB-24

- **Jumper Bar Kit 3 Ckt. to 1 Ckt. RXBJ-A31** is used to convert single phase multiple three circuit units to a single supply circuit. Kit includes cover and screw for line side terminals.
- **Jumper Bar Kit 2 Ckt. to 1 Ckt. RXBJ-A21** is used to convert single phase multiple two circuit units to a single supply circuit. Kit includes cover and screw for line side terminals.
- **Note:** No jumper bar kit is available to convert three phase multiple two circuit units to a single supply circuit.

• Auxiliary Horizontal Overflow Pan Accessory RXBM-

Nominal Cooling Capacity-Tons	Auxiliary Horizontal Overflow Pan Accessory Model Number
2 - 3	RXBM-AC48
4 - 5	RXBM-AC61

• Supply and Return Air Sensor Kit RXHT-A02

The RXHT-A02 Thermistor Kit is to be used with the air handler control to monitor the system return and leaving air temperatures. These temperatures can be monitored with the EcoNet communicating thermostat.

Grounding

- This product must be sufficiently grounded in accordance with National Electrical Code (C.E.C. in Canada) and any applicable local ordinance.
- A grounding lug is provided.

• Auxiliary Electric Heater Kits RXBH-

Heater Kits include circuit breakers which meet UL and cUL requirements for service disconnect. See the Electric Heat Electrical Data in this specification sheet for specific Heater Kit Model numbers.

• Horizontal Adapter Kit RXHH-

This horizontal adapter kit is used to convert Upflow/Downflow only models to horizontal flow. See the following table to order proper horizontal adapter kit.

Coil Model	Horizontal Adapter Kit Model Number (Single Qty.)	Horizontal Adapter Kit Model Number (10-Pack Qty.)
2414	RXHH-A01	RXHH-A01 x 10
2417	RXHH-A02	RXHH-A02 x 10
2421/3617/3621	RXHH-A03	RXHH-A03 x 10
4821/4824/6021	RXHH-A06	RXHH-A06 x 10
6024	RXHH-A05	RXHH-A05 x 10

• External Filter Base RXHF-

Model Cabinet Size	Filter Size In. [mm]	Part Number*	A	B
17	16 x 20 [406 x 508]	RXHF-17	15.70	17.5
21	20 x 20 [508 x 508]	RXHF-21	19.20	21.0
24	25 x 20 [635 x 508]	RXHF-24	22.70	25.5

*Accommodates 1" or 2" filter

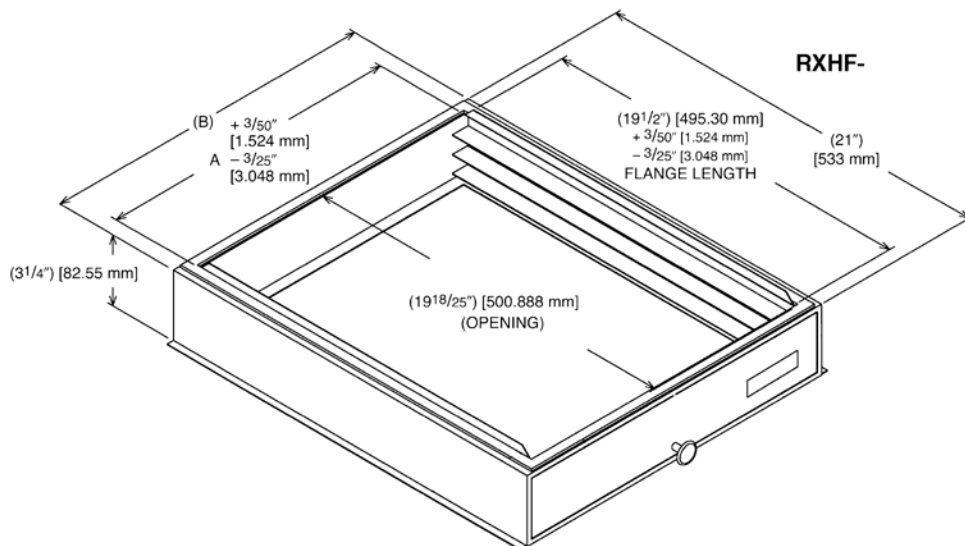

[] Designates Metric Conversions