

ENDEAVOR™



H E A T P U M P A N D A I R C O N D I T I O N E R G U I D E



Rheem.com/Endeavor

High Performance and Sustainability Have Never Felt So Good

Keep consistently comfortable year-round with the Rheem® Endeavor™ Line of Heat Pumps and Air Conditioners. The Rheem Endeavor Line offers an excellent range of choices designed for lasting energy-efficient comfort that saves you money while delivering peace of mind.



Relax with Consistently Hot... or Cold Temperatures



PEACE-OF-MIND PERFORMANCE

Relax, you're covered by one of the best warranties in the industry¹ —up to 10 Year Limited Parts + 10 Year Conditional Unit Replacement².



QUIET OPERATION

Efficient home comfort shouldn't be noisy. That's why our air conditioners and heat pumps are designed with acoustics in mind. Integrated sound-dampening features such as refrigerant tubing design, fan blade approach, composite base pan and innovative compressor and drive technologies let you enjoy more efficiency —and less noise³.



REDUCED EMISSIONS

Households generate 72%⁴ of greenhouse gas emissions, so switching to a heat pump can make a big difference for the environment —today.



HIGH COMFORT

Inverter-driven, variable speed compressor⁵ (between 40% and 100% of capacity), variable speed twin rotary compressor⁶ (between 40% and 70% of capacity, ramping up to 100% when required), two-stage⁷ (high, low) or single-stage⁸ technology work to continuously meet your ever-changing cooling needs. You'll enjoy steady temperature and advanced humidity control that combine to exceed your optimal comfort expectations.



EcoNet[®]



Several of the Rheem Endeavor Line Heat Pumps and Air Conditioners operate with the easy-to-use EcoNet Smart Thermostat, which optimizes system performance and provides a new level of protection and precision comfort with features like:

- Communication with latest sensor technology
- Control of your thermostat from anywhere via the EcoNet App⁹
- Alerts sent directly to your phone or email



Helping You Live Both Comfortably and Sustainably

Several of the Rheem Endeavor Line Heat Pumps and Air Conditioners have earned our Sustainability Standout Seal, indicating they're among the best of the best. We created the Seal to help you more easily find the products that save energy, save money and save the planet.



Among Heat Pumps and Air Conditioners, These Are Stars

Earning ENERGY STAR[®] recognition means products meet strict energy efficiency guidelines set by the U.S. Environmental Protection Agency and several of the Rheem Endeavor Heat Pumps and Air Conditioners are ENERGY STAR[®] certified, offering annual energy cost savings¹⁰.



Simplified Install & Service with Bluetooth Technology

Built-in Bluetooth[®] connectivity¹¹ on many of the Heat Pump and Air Conditioner models make it faster and easier for your contractor to install and service your new system. This can help lower your costs and help make your home comfortable again —fast.



TESTED. TRUSTED. TOUGH.

From the smallest part to complete comfort systems, we build quality into everything we make so we can be sure it's tough enough to deliver the ultimate performance you can count on day after day, year after year. That reliability is what makes Rheem different —and better.



We Thought of Everything... & Then Some

We evaluate every detail of a product from top to bottom, inside and out and every angle in between. That's 360+1. And that's why you can count on these heat pumps and air conditioners to bring you and your family years of efficient and dependable comfort.

Rheem® Endeavor™ Line Heat Pump Series*

*ENERGY STAR® certified
RP15AZ will launch in 2023



Welcome year-round comfort into your home with the Rheem® Endeavor™ Line of Heat Pumps. Each model is designed to provide super-efficient and consistent heating and cooling technology to keep your utility bills dependably low, season after season.

	Prestige®	Classic Plus®	Classic®	Select™
	RP18AZ	RP16AZ	RP14AZ	WP14AZ
Cooling & Heating Efficiency¹²	19 SEER2 / 12.5 EER2 / 8.5 HSPF2	17 SEER2 / 10.4 EER2 / 8.1 HSPF2	14.3 SEER2 / 9 EER2 / 7.5 HSPF2	14.3 SEER2 / 9 EER2 / 7.5 HSPF2
Nominal Sizes	2 to 5 tons	2 to 5 tons	1.5 to 5 tons	1.5 to 5 tons
Cabinet Type Designator	iM	iM	iM	iC
Cooling & Heating Capacities	22.8 to 54 kBTU	22.8 to 56 kBTU	17.1 to 55.5 kBTU	17.1 to 55.5 kBTU
EcoNet® Enabled	Yes	Yes	No	No
Sound Rating³ (as low as)	58 dB	60 dB	72 dB	72 dB
Compressor Type	Inverter Driven, Variable Speed	Inverter Driven, Variable Speed Twin Rotary	Two-Stage	Two-Stage
Condenser Coil Type	3/8 in.	7mm ¹³	7mm ¹³	7mm ¹³
ENERGY STAR® Certified¹⁰	Yes	No	No	No
Bluetooth Connectivity¹¹	Yes	Yes	No	No
PlusOne® Features & More (PlusOnes indicated in bold)	Expanded Valve Space and Triple Service Access Rheem Contractor and EcoNet Apps®, built-in EcoNet and Bluetooth technology allows for easy install and diagnostics	Expanded Valve Space and Triple Service Access Rheem Contractor and EcoNet Apps®, built-in EcoNet and Bluetooth technology allows for easy install and diagnostics	Expanded Valve Space and Triple Service Access	n/a
Compatible Thermostat	EcoNet Smart Thermostat — Two-Stage 24V (Emergency Only)	EcoNet Smart Thermostat — Two-Stage 24V (Three-Speed Operation Only)	Two-Stage 24V	Two-Stage 24V
Sustainability Standout	Yes	Yes	No	No
Limited Warranty¹	Parts – 10 years — Unit Replacement – 10 years (registration required)	Parts – 10 years — Unit Replacement – 10 years (registration required)	Conditional Parts – 10 years (registration required)	Parts – 5 years

Rheem® Endeavor™ Line Air Conditioner Series



Keep cool, even when the utility bill arrives, with the Rheem® Endeavor™ Line of Air Conditioners. Each model is designed to provide super high efficiency, keeping your home dependably comfortable.

	Prestige®	Classic Plus®		Classic®		Select™		
	RA18AZ	RA16AZ	RA15AZ	RA14AZ	RA13NZ	WA15AZ	WA14AZ	WA13NZ
Cooling Efficiency¹²	19 SEER2 / 12 EER2	17 SEER2 / 10.5 EER2	15.2 SEER2 / 9.8 EER2	15.2 SEER2 / 12 EER2	15.2 SEER2 / 12 EER2	15.2 SEER2 / 9.8 EER2	15.2 SEER2 / 12 EER2	15.2 SEER2 / 12 EER2
Nominal Sizes	2 to 5 tons	2 to 5 tons	2 to 5 tons	1.5 to 5 tons	1.5 to 5 tons	2 to 5 tons	1.5 to 5 tons	1.5 to 5 tons
Cabinet Type Designator	iM	iM	iM	iM	iM	iC	iC	iC
Cooling Capacities	22.8 to 54 kBTU	22.8 to 56 kBTU	22.8 to 56 kBTU	17.1 to 55.5 kBTU	17.1 to 55.5 kBTU	22.8 to 56 kBTU	17.1 to 55.5 kBTU	17.1 to 55.5 kBTU
EcoNet® Enabled	Yes	Yes	Yes	No	No	No	No	No
Sound Rating³ (as low as)	54 dB	72 dB	72 dB	69 dB	68 dB	60 dB	69 dB	68 dB
Compressor Type	Inverter Driven, Variable Speed	Inverter Driven, Variable Speed Twin Rotary	Inverter Driven, Variable Speed Twin Rotary	Single-Stage	Single-Stage	Inverter Driven, Variable Speed Twin Rotary	Single-Stage	Single-Stage
Condenser Coil Type	3/8 in.	7mm ¹³	7mm ¹³	7mm ¹³	7mm ¹³	7mm ¹³	7mm ¹³	7mm ¹³
ENERGY STAR® Certified¹⁰	Yes	No	No	Yes	Yes	No	Yes	Yes
Bluetooth Connectivity¹¹	Yes	Yes	Yes	No	No	Yes	No	No
PlusOne® Features & More (PlusOnes indicated in bold)	Expanded Valve Space and Triple Service Access Rheem Contractor and EcoNet Apps®, built-in EcoNet and Bluetooth technology allows for easy install and diagnostics	Expanded Valve Space and Triple Service Access Rheem Contractor and EcoNet Apps®, built-in EcoNet and Bluetooth technology allows for easy install and diagnostics	Expanded Valve Space and Triple Service Access Rheem Contractor and EcoNet Apps®, built-in EcoNet and Bluetooth technology allows for easy install and diagnostics	Expanded Valve Space and Triple Service Access	Expanded Valve Space and Triple Service Access	n/a	n/a	n/a
Compatible Thermostat	EcoNet Smart Thermostat — Two-Stage 24V (Emergency Only)	EcoNet Smart Thermostat — Two-Stage 24V (Three-speed Operation Only)	EcoNet Smart Thermostat — Two-Stage 24V (Three-speed Operation Only)	Single-Stage 24V	Single-Stage 24V	Two-Stage 24V	Single-Stage 24V	Single-Stage 24V
Sustainability Standout	Yes	Yes	Yes	No	No	No	No	No
Limited Warranty¹	Parts – 10 years — Unit Replacement – 10 years (registration required)	Parts – 10 years — Unit Replacement – 10 years (registration required)	Parts – 10 years	Conditional Parts – 10 years (registration required)	Conditional Parts – 10 years (registration required)	Parts – 5 years	Parts – 5 years	Parts – 5 years





Rheem.com

Nearly 100 Years of Innovation

As the only brand bringing innovative air and water solutions to homes and businesses around the world, Rheem continues to deliver advanced comfort, savings and experiences to our customers—just as we've done for nearly 100 years.



Rheem USA

5600 Old Greenwood Road
Fort Smith, Arkansas 72908



Rheem Canada Ltd. / Ltée

125 Edgeware Road, Unit 1
Brampton, Ontario L6Y 0P5

In keeping with its policy of continuous progress and product improvement, Rheem reserves the right to make changes without notice.

¹Registration is required for the conditional parts and unit replacement warranty (if applicable). For complete details of the limited and conditional warranties, including applicable terms and conditions, contact your local Contractor or go to Rheem.com for a copy of the product warranty certificate. ²Refer to the chart for specific warranty terms by product. ³Based on Internal R&D Testing, May 2022. Sound levels are also dependent on proper installation and location of outdoor product. ⁴Residential Building Electrification in CA: Consumer economics, greenhouse gases and grid impacts, April 2019. ⁵Applies to RP18AZ and RA18AZ models. ⁶Applies to the RP16AZ, RA16AZ, RA15AZ and WA15AZ models. ⁷Applies to the RP14AZ model and WP14AZ. ⁸Applies to RP14AZ, RA14AZ, RA13NZ, WP14AZ, WA14AZ and WA13NZ models. ⁹WiFi broadband internet connection required. Download the EcoNet® App from the App Store® or Google Play™ to set up your EcoNet Smart Thermostat. Receipt of notifications depend on home WiFi set up. Amazon, Alexa and all related logos are trademarks of Amazon.com, Inc. or its affiliates. ¹⁰Proper sizing and installation of equipment is critical to achieve optimal performance. Split system air conditioners and heat pumps must be matched with appropriate coil components to meet ENERGY STAR® criteria. Ask your contractor for details or visit EnergyStar.gov. ¹¹Applies to RP18AZ, RP16AZ, RA18AZ, RA16AZ, RA15AZ and WA15AZ models. ¹²SEER (Seasonal Energy Efficiency Rating) / EER (Energy Efficiency Ratio) / HSPF (Heating Seasonal Performance Factor): The higher the SEER / EER / HSPF rating, the more efficient the unit. ¹³5-ton models feature a 3/8 in. condenser coil.



System option with heat pumps only

© 2022 Rheem Manufacturing Company. Rheem trademarks owned by Rheem Manufacturing Company.
Printed in the USA | 10/22 | QG | Form No. M11-1100



The new degree of comfort.®

Endeavor™ Line Select® Series iC Air Conditioners



WA14AZ

Cooling Efficiency up to: 15.2 SEER2/12 EER2

Nominal Sizes: 1½ to 5 Ton [5.28 to 17.6 kW]

Cooling Capacities: 17.1 to 55.5 kBTU [5.0 to 16.3 kW]



† A.F.U.E. (Annual Fuel Utilization Efficiency) calculated in accordance with Department of Energy test procedures.

****Proper sizing and installation of equipment is critical to achieve optimal performance. Split system air conditioners and heat pumps must be matched with appropriate coil components to meet Energy Star. Ask your Contractor for details or visit www.energystar.gov.***

Table of Contents

Features & Benefits	3
Model Number Identification	4
General Data/Electrical Data	5
Accessories	6
Weighted Sound Power	6
Unit Dimensions	7
Clearances	8
Control Wiring	9
Application Guidelines.....	9
Refrigerant Line Size Information	10-13
Performance Data	14
Limited Warranty	16

Features and Benefits

- **Fully Louvered Steel Cabinet:** Features durable construction to add protection from yard hazards, weather corrosion
- **Optimized 7 mm Coil Design:** Allows for improved airflow, heat transfer and energy consumption
- **Easily Accessible Control Box:** Ease of installation and serviceability

Air Conditioners

<u>W</u>	<u>A</u>	<u>14</u>	<u>A</u>	<u>Z</u>	<u>18</u>	<u>A</u>	<u>J</u>	<u>1</u>	<u>N</u>	<u>A</u>
Brand	Product Category	SEER2	Region	Refrigerant	Capacity BTU/HR	Major Series	Voltage	Type	Controls	Minor Series
W - Rheem Select	A - Air Conditioners	14 - 13.8/14.3 SEER2	A - All	Z - R-410A	18 - 18,000 [5.28 kW] 24 - 24,000 [7.03 kW] 30 - 30,000 [8.79 kW] 36 - 36,000 [10.55 kW] 42 - 42,000 [12.31 kW] 48 - 48,000 [14.07 kW] 60 - 60,000 [17.58 kW]	A - 1st Design	J - 208/230/1/60	1 - 1-Stage	N - Non-Communicating	A - 1st Design

[] Designates Metric Conversions

AVAILABLE MODELS
WA14AZ18AJ1NA
WA14AZ24AJ1NA
WA14AZ30AJ1NA
WA14AZ36AJ1NA
WA14AZ42AJ1NA
WA14AZ48AJ1NA
WA14AZ60AJ1NA

STANDARD EQUIPMENT
R410-A Refrigerant
Scroll Compressor
Field Installed Filter Drier
Front Seating Service Valves
Internal Pressure Relief Valve
Internal Thermal Overload
Long Line Capability
Low Ambient Cabability with Kit
Optimized Venturi Airflow
Rust Resistant Screws
QR Code
External Gauge Ports

General Data							
GENERAL DATA							
Model No.	WA14AZ18	WA14AZ24	WA14AZ30	WA14AZ36	WA14AZ42	WA14AZ48	WA14AZ60
Nominal Tonnage	1.5	2.0	2.5	3.0	3.5	4.0	5.0
Valve Connections							
Liquid Line O.D. – in.	3/8	3/8	3/8	3/8	3/8	3/8	3/8
Suction Line O.D. – in.	3/4	3/4	3/4	3/4	7/8	7/8	7/8
Refrigerant (R410A) furnished oz.¹	94	115	120	124	149	153	203
Compressor Type	Scroll						
Outdoor Coil							
Net face area – Outer Coil	10.9	13.3	14.3	16.4	19.5	19.5	32.5
Net face area – Inner Coil	10.5	12.9	13.9	15.9	18.8	18.8	—
Tube diameter – in.	0.276	0.276	0.276	0.276	0.276	0.276	3/8
Number of rows	2	2	2	2	2	2	1
Fins per inch	24	24	24	24	24	24	22
Outdoor Fan							
Diameter – in.	20	24	24	24	24	24	26
Number of blades	2	2	2	2	3	3	3
Motor hp	1/7	1/6	1/6	1/6	1/5	1/5	1/3
CFM	2156	2723	2830	2991	3655	3655	5178
RPM	1075	825	825	825	850	850	910
watts	152	161	165	145	214	214	271
Shipping weight – lbs.	151	185	171	185	236	228	294
Operating weight – lbs.	144	178	164	178	229	221	287
Electrical Data							
Line Voltage Data (Volts-Phase-Hz)	208/230-1-60	208/230-1-60	208/230-1-60	208/230-1-60	208/230-1-60	208/230-1-60	208/230-1-60
Maximum overcurrent protection (amps)²	20	25	30	30	40	40	60
Minimum circuit ampacity³	14	18	19	20	24	24	40
Compressor							
Rated load amps	9	12	14	13	18	18	26
Locked rotor amps	43	60	68	83	110	102	150
Condenser Fan Motor							
Full load amps	0.8	0.8	0.8	0.8	1.0	1.0	2.8
Locked rotor amps	1.5	1.5	1.7	1.7	2.6	2.6	—

¹Refrigerant charge sufficient for 15 ft. length of refrigerant lines. For longer line set requirements see the installation instructions for information about set length and additional refrigerant charge required.

²HACR type circuit breaker or fuse.

³Refer to National Electrical Code manual to determine wire, fuse and disconnect size requirements.

Accessories

Model No.	WA14AZ18	WA14AZ24	WA14AZ30	WA14AZ36	WA14AZ42	WA14AZ48	WA14AZ60
Compressor crankcase heater*	44-17402-44	44-17402-44	44-17402-44	44-17402-44	44-17402-45	44-17402-45	44-17402-45
Low ambient control	RXAD-A08	RXAD-A08	RXAD-A08	RXAD-A08	RXAD-A08	RXAD-A08	RXAD-A08
Compressor sound cover	68-23427-26	68-23427-26	68-23427-26	68-23427-26	68-23427-25	68-23427-25	68-23427-25
Compressor hard start kit	SK-A1	SK-A1	SK-A1	SK-A1	SK-A1	SK-A1	SK-A1
Compressor time delay	RXMD-B01	RXMD-B01	RXMD-B01	RXMD-B01	RXMD-B01	RXMD-B01	RXMD-B01
Low pressure control	RXAC-A07	RXAC-A07	RXAC-A07	RXAC-A07	RXAC-A07	RXAC-A07	RXAC-A07
High pressure control	RXAB-A07	RXAB-A07	RXAB-A07	RXAB-A07	RXAB-A07	RXAB-A07	RXAB-A07
Liquid Line Solenoid (24 VAC, 50/60 Hz)	Solenoid Valve	200RD2T3TVLC	200RD2T3TVLC	200RD2T3TVLC	200RD2T3TVLC	200RD2T3TVLC	200RD2T3TVLC
	Solenoid Coil	61-AMG24V	61-AMG24V	61-AMG24V	61-AMG24V	61-AMG24V	61-AMG24V
Liquid Line Solenoid (120/240 VAC, 50/60 Hz)	Solenoid Valve	200RD2T3TVLC	200RD2T3TVLC	200RD2T3TVLC	200RD2T3TVLC	200RD2T3TVLC	200RD2T3TVLC
	Solenoid Coil	61-AMG120/240V	61-AMG120/240V	61-AMG120/240V	61-AMG120/240V	61-AMG120/240V	61-AMG120/240V

*Crankcase Heater recommended with Low Ambient Kit.

Weighted Sound Power Level (dBA)

Unit Size - Voltage, Series	Standard Rating (dBA)	TYPICAL OCTAVE BAND SPECTRUM (dBA without tone adjustment)						
		125	250	500	1000	2000	4000	8000
WA14AZ18	70.7	48.2	56.0	61.9	61.0	56.5	53.5	45.7
WA14AZ24	75.7	46.5	62.0	68.1	64.5	60.8	55.2	48.4
WA14AZ30	76.8	48.2	62.5	68.8	65.8	62.0	57.2	49.6
WA14AZ36	76.1	48.4	58.7	67.3	65.5	62.6	58.8	52.1
WA14AZ42	72.5	46.6	55.3	63.9	62.1	59.4	55.2	48.2
WA14AZ48	74.0	45.4	55.7	64.2	62.9	60.8	56.7	51.2
WA14AZ60	75.8	43.4	59.8	67.2	65.5	62.7	59.2	53.1

NOTE: Tested in accordance with AHRI Standard 270-08 (not listed in AHRI)

Unit Dimensions

MODEL NO.	OPERATING						SHIPPING							
	H (Height)		L (Length)		W (Width)		H (Height)		L (Length)		W (Width)	OP. WEIGHT LBS.	SHIPPING WEIGHT LBS.	
	INCHES	mm	INCHES	mm	INCHES	mm	INCHES	mm	INCHES	mm				
WA14AZ18AJ1NA	25.65	651.51	29.54	750	29.54	750	27.0625	687.3875	32.625	828.675	32.625	828.675	122	143
WA14AZ24AJ1NA	25.65	651.51	33.66	855	33.66	855	27.0625	687.3875	36.625	930.275	36.625	930.275	141	148
WA14AZ30AJ1NA	27.65	702.31	33.66	855	33.66	855	29.0625	738.1875	36.625	930.275	36.625	930.275	151	158
WA14AZ36AJ1NA	31.65	803.91	33.66	855	33.66	855	33.0625	839.7875	36.625	930.275	36.625	930.275	171	178
WA14AZ42AJ1NA	35.65	905.51	33.66	855	33.66	855	37.0625	941.3875	36.625	930.275	36.625	930.275	200	207
WA14AZ48AJ1NA	35.65	905.51	33.66	855	33.66	855	37.0625	941.3875	36.625	930.275	36.625	930.275	221	232
WA14AZ60AJ1NA	51.65	1311.91	35.54	903	35.54	903	53.0625	1347.7875	38.625	981.075	38.625	981.075	261	268

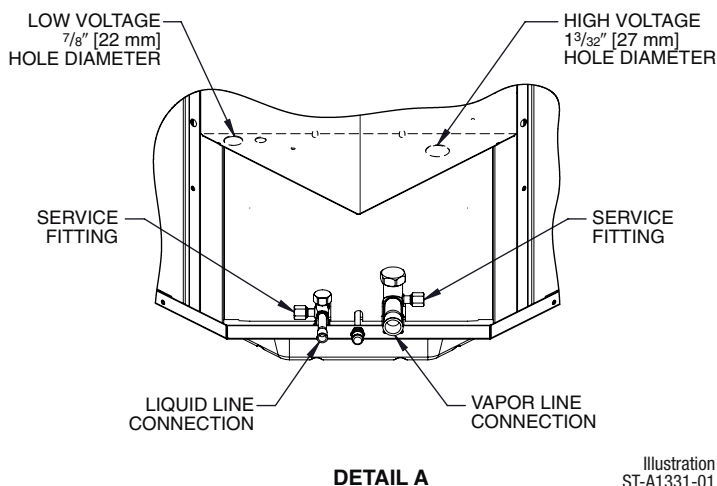
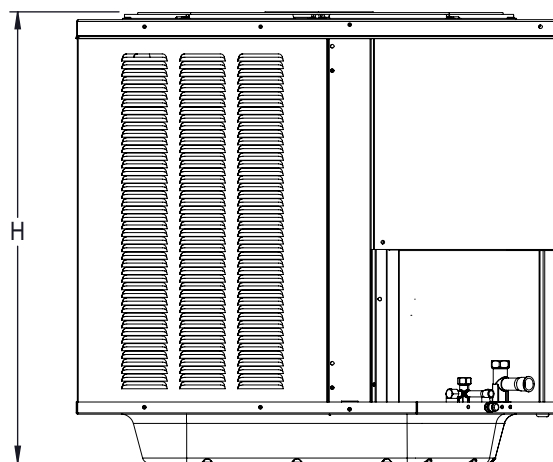
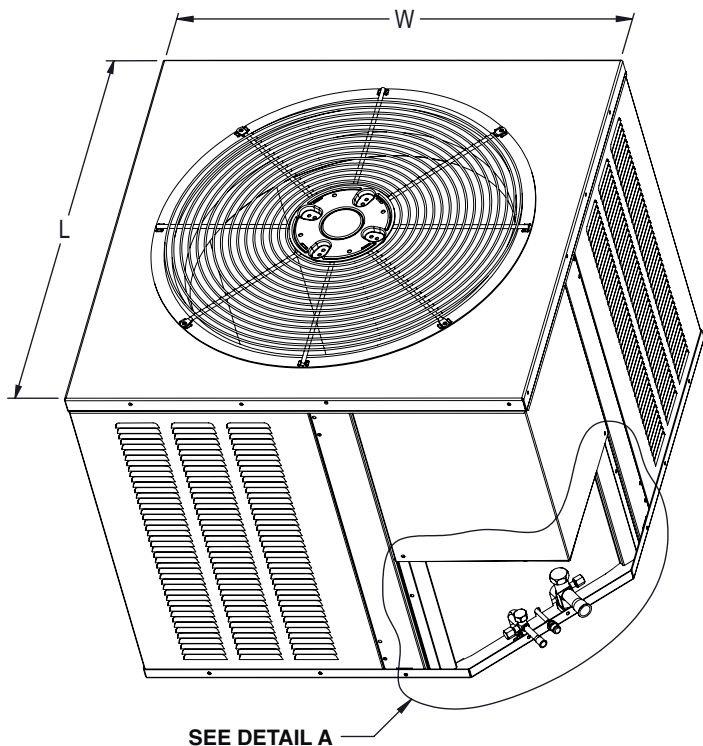
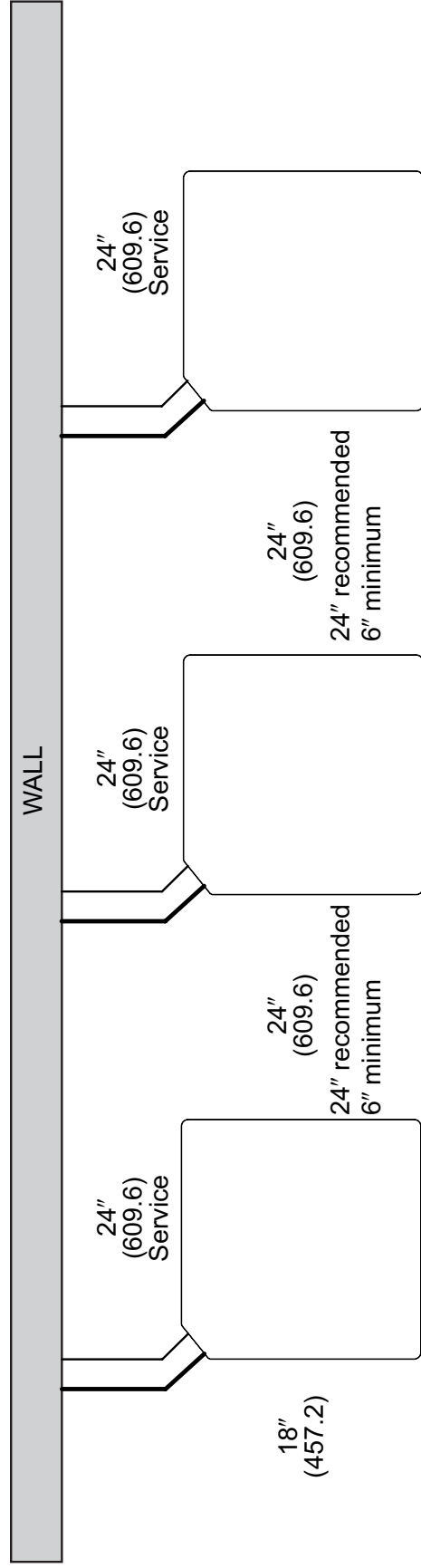
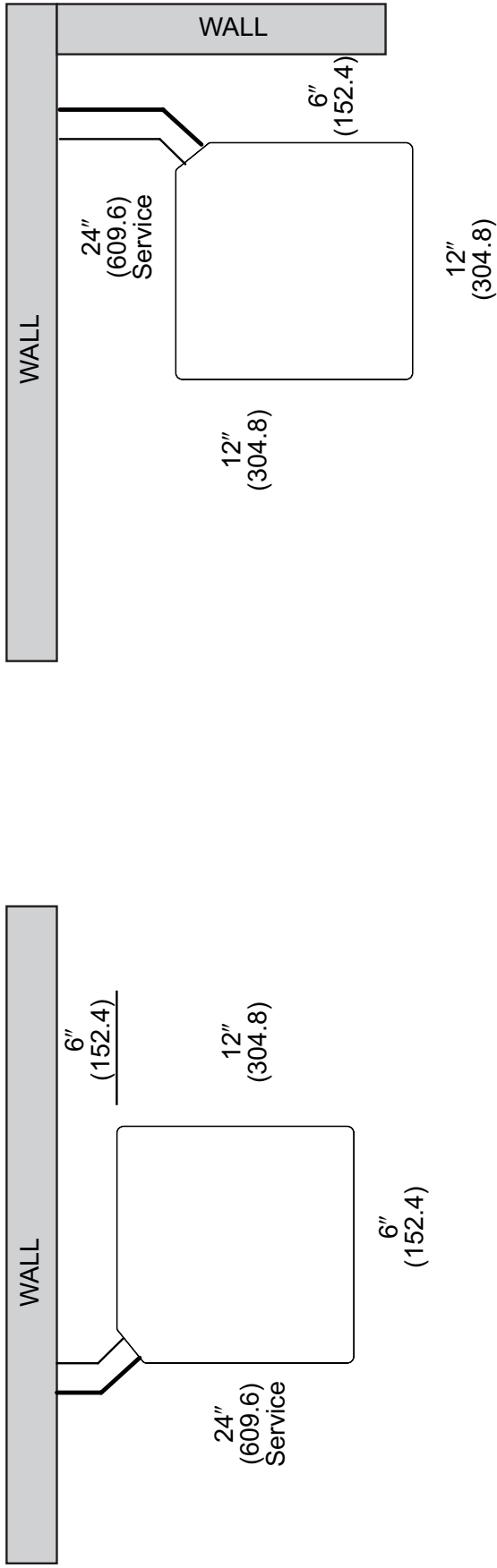

Illustration
ST-A1331-01
Rev. 10-20-2022

NOTE: Illustrations show the deep drawn basepan.

[] Designates Metric Conversions

CLEARANCES



NOTE: NUMBERS IN () = mm

IMPORTANT: When installing multiple units in an alcove, roof well or partially enclosed area, ensure there is adequate ventilation to prevent re-circulation of discharge air.

Control Wiring

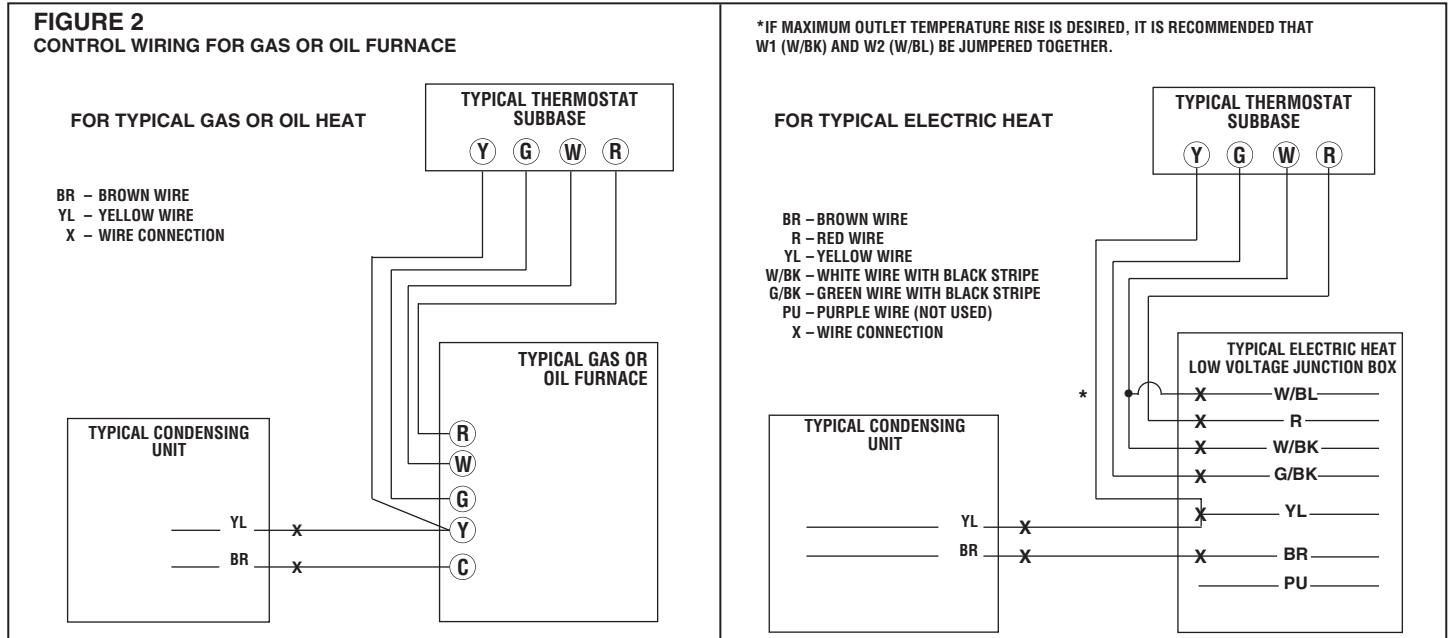

Application Guidelines

1. Intended for outdoor installation with free air inlet and outlet. Outdoor fan external static pressure available is less than 0.01 -in. wc.
2. Minimum outdoor operation air temperature for cooling mode without low-ambient operation accessory is 55°F (12.8°C).
3. Maximum outdoor operating air temperature is 125°F (51.7°C).
4. For reliable operation, unit should be level in all horizontal planes.
5. Use only copper wire for electric connections at unit. Aluminum and clad aluminum are not acceptable for the type of connector provided.
6. Do not apply capillary tube indoor coils to these units.
7. Factory-supplied filter drier must be installed.

Refrigerant Line Size Information

14.3 SEER2 Single-Stage Air-Conditioners															
Unit Size	Allowable Liquid Line Size	Allowable Suction Line Size	Apply Long Line Guidelines if Linear Line Length Exceeds Those Shown Below (Feet)	Equivalent Length (Feet)											
				< 25	26-50	51-75	76-100	101-125	126-150	151-175	176-200	201-225	226-250		
				Maximum Vertical Rise (Outdoor Unit Below Indoor Unit) * / Capacity Multiplier											
(-)A14AZ				25/1.00	50/0.99	62/0.98	43/0.98	24/0.97	57/0.97	NR	NR	NR	NR	NR	NR
1.5 Ton **SEE NOTE 3	1/4"	5/8"	N/A	25/1.00	50/0.99	62/0.98	43/0.98	24/0.97	57/0.97	NR	NR	NR	NR	NR	NR
	5/16"	5/8"	223	25/1.00	50/0.99	75/0.98	98/0.98	93/0.97	88/0.97	83/0.96	78/0.96	73/0.95	68/0.94	61/0.93	37/0.90
	3/8"	5/8"	148	25/1.00	50/0.99	75/0.98	100/0.98	100/0.97	100/0.97	100/0.96	100/0.96	100/0.95	100/0.94	98/0.93	89/0.90
	1/4"	3/4"	**	25/1.00	50/1.00	62/0.99	43/0.99	24/0.99	57/0.99	NR	NR	NR	NR	NR	NR
	5/16"	3/4"	**	25/1.00	50/1.00	75/0.99	98/0.99	93/0.99	88/0.99	83/0.99	78/0.98	73/0.98	68/0.98	61/0.93	37/0.90
	3/8"	3/4"	**	25/1.00	50/1.00	75/1.00	100/0.99	100/0.99	100/0.99	100/0.99	100/0.99	100/0.98	100/0.98	100/0.98	100/0.98
2 Ton	1/4"	5/8"	N/A	25/0.99	50/0.98	21/0.97	NR	NR	NR	NR	NR	NR	NR	NR	NR
	5/16"	5/8"	213	25/0.99	50/0.98	75/0.97	87/0.96	77/0.95	69/0.94	61/0.93	53/0.92	45/0.91	37/0.90	36/0.90	NR
	3/8"	5/8"	142	25/0.99	50/0.98	75/0.97	100/0.96	100/0.95	100/0.94	98/0.93	95/0.92	92/0.91	89/0.90	90/0.90	NR
	1/4"	3/4"	N/A	25/1.00	50/1.00	21/0.99	NR	NR	NR	NR	NR	NR	NR	NR	NR
	5/16"	3/4"	213	25/1.00	50/1.00	75/0.99	87/0.99	77/0.98	69/0.98	61/0.98	53/0.97	45/0.97	37/0.96	36/0.96	NR
	3/8"	3/4"	142	25/1.00	50/1.00	75/0.99	100/0.99	100/0.98	100/0.98	100/0.98	98/0.98	95/0.97	93/0.97	90/0.96	90/0.96
2.5 Ton	5/16"	5/8"	N/A	25/0.99	50/0.98	75/0.96	70/0.94	59/0.93	48/0.91	36/0.90	NR	NR	NR	NR	NR
	3/8"	5/8"	117	25/0.99	50/0.98	75/0.96	100/0.94	98/0.93	94/0.91	90/0.90	NR	NR	NR	NR	NR
	5/16"	3/4"	175	25/1.00	50/0.99	75/0.99	70/0.98	59/0.98	48/0.97	36/0.96	25/0.96	13/0.95	NR	36/0.96	NR
	3/8"	3/4"	117	25/1.00	50/0.99	75/0.99	100/0.98	98/0.98	94/0.97	90/0.96	86/0.96	82/0.95	78/0.95	90/0.96	78/0.95
	5/16"	5/8"	N/A	25/0.99	50/0.97	66/0.94	49/0.92	32/0.90	NR	NR	NR	NR	NR	NR	NR
	3/8"	5/8"	85	25/0.99	50/0.97	75/0.94	95/0.92	89/0.90	NR	NR	NR	NR	NR	NR	NR
3 Ton	5/16"	3/4"	128	25/1.00	50/0.99	66/0.98	49/0.98	32/0.97	15/0.96	NR	NR	NR	NR	NR	NR
	3/8"	3/4"	85	25/1.00	50/0.99	75/0.98	95/0.98	89/0.97	84/0.96	78/0.95	72/0.94	67/0.93	61/0.93	78/0.95	61/0.93
	1/2"	3/4"	43	25/1.00	50/0.99	75/0.98	100/0.98	100/0.97	100/0.96	100/0.96	100/0.95	100/0.93	100/0.93	100/0.95	100/0.93
	5/16"	7/8"	128	25/1.00	50/1.00	66/1.00	49/0.99	32/0.99	15/0.99	NR	NR	NR	NR	NR	NR
	3/8"	7/8"	85	25/1.00	50/1.00	75/1.00	95/0.99	89/0.99	84/0.99	78/0.98	72/0.98	67/0.98	61/0.97	78/0.98	61/0.97
	1/2"	7/8"	43	25/1.00	50/1.00	75/1.00	100/0.99	100/0.99	100/0.99	100/0.99	100/0.98	100/0.98	100/0.97	100/0.98	100/0.97
3.5 Ton	3/8"	3/4"	102	25/0.99	50/0.98	75/0.97	88/0.96	80/0.95	72/0.94	65/0.92	57/0.91	49/0.90	NR	65/0.92	NR
	1/2"	3/4"	51	25/0.99	50/0.98	75/0.97	100/0.96	100/0.95	100/0.94	100/0.92	100/0.91	100/0.90	NR	100/0.92	NR
	3/8"	7/8"	102	25/1.00	50/1.00	75/0.99	88/0.99	80/0.99	72/0.98	65/0.97	57/0.97	49/0.96	42/0.96	65/0.97	42/0.96
	1/2"	7/8"	51	25/1.00	50/1.00	75/0.99	100/0.99	100/0.99	100/0.98	100/0.98	100/0.97	100/0.97	100/0.96	100/0.97	100/0.96

NOTES:

- 1) Do not exceed 200 ft linear line length.
- 2) *Do not exceed 100 ft vertical separation if outdoor unit is above indoor unit.
- 3) **3/4" suction line should only be used for 1.5 ton systems if outdoor unit is below or at same level as indoor to assure proper oil return.
- 4) Always use the smallest liquid line allowable to minimize refrigerant charge.
- 5) Applications shaded in light gray indicate capacity multipliers between 0.90 and 0.96 which are not recommended, but are allowed.
- 6) Applications shaded in dark gray are not recommended due to excessive liquid or suction pressure drop.

Refrigerant Line Size Information (Con't.)

14.3 SEER2 Single-Stage Air-Conditioners													
Unit Size	Allowable Liquid Line Size	Allowable Suction Line Size	Apply Long Line Guidelines if Linear Line Length Exceeds Those Shown Below (Feet)	Equivalent Length (Feet)									
				< 25	26-50	51-75	76-100	101-125	126-150	151-175	176-200	201-225	226-250
				Maximum Vertical Rise (Outdoor Unit Below Indoor Unit) * / Capacity Multiplier									
4 Ton	3/8"	3/4"	110	25 / 0.99	50 / 0.98	75 / 0.96	77 / 0.95	67 / 0.93	57 / 0.92	46 / 0.91	NR	NR	NR
	1/2"	3/4"	55	25 / 0.99	50 / 0.98	75 / 0.96	100 / 0.95	100 / 0.93	100 / 0.92	100 / 0.91	NR	NR	NR
	3/8"	7/8"	110	25 / 1.00	50 / 0.99	75 / 0.99	77 / 0.98	67 / 0.97	57 / 0.97	46 / 0.96	36 / 0.96	26 / 0.95	15 / 0.95
	1/2"	7/8"	55	25 / 1.00	50 / 0.99	75 / 0.99	100 / 0.98	100 / 0.97	100 / 0.97	100 / 0.96	100 / 0.96	99 / 0.95	97 / 0.95
5 Ton	3/8"	3/4"	0	25 / 0.99	50 / 0.97	75 / 0.94	61 / 0.92	46 / 0.90	NR	NR	NR	NR	NR
	1/2"	3/4"	0	25 / 0.99	50 / 0.97	75 / 0.94	100 / 0.92	100 / 0.90	NR	NR	NR	NR	NR
	3/8"	7/8"	0	25 / 1.00	50 / 0.99	75 / 0.98	61 / 0.97	46 / 0.96	32 / 0.95	18 / 0.94	NR	NR	NR
	1/2"	7/8"	0	25 / 1.00	50 / 0.99	75 / 0.98	100 / 0.97	100 / 0.96	100 / 0.95	97 / 0.94	95 / 0.94	92 / 0.93	89 / 0.92
	3/8"	1-1/8"	0	25 / 1.01	50 / 1.01	75 / 1.00	61 / 1.00	46 / 0.99	32 / 0.99	18 / 0.99	NR	NR	NR
	1/2"	1-1/8"	0	25 / 1.01	50 / 1.01	75 / 1.00	100 / 1.00	100 / 0.99	100 / 0.99	97 / 0.99	95 / 0.99	92 / 0.99	89 / 0.98

NOTES:

- 1) Do not exceed 200 ft linear line length.
- 2) *Do not exceed 100 ft vertical separation if outdoor unit is above indoor unit.
- 3) **3/4" suction line should only be used for 1.5 ton systems if outdoor unit is below or at same level as indoor to assure proper oil return.
- 4) Always use the smallest liquid line allowable to minimize refrigerant charge.
- 5) Applications shaded in light gray indicate capacity multipliers between 0.90 and 0.96 which are not recommended, but are allowed.
- 6) Applications shaded in dark gray are not recommended due to excessive liquid or suction pressure drop.

Refrigerant Line Size Information (Con't.)

14.3 SEER2 Single-Stage Air-Conditioners																		
Unit Size	Allowable Liquid Line Size mm [in.]	Allowable Suction Line Size mm [in.]	Apply Long Line Guidelines if Linear Line Length Exceeds Those Shown Below (Feet)	Equivalent Length (Meters)							70-76							
				< 8	8-15	16-23	24-30	31-38	39-46	47-53		54-61	62-69					
				Maximum Vertical Rise (Outdoor Unit Below Indoor Unit) * / Capacity Multiplier														
(-)A14AZ				8 / 1.00	15 / 0.99	19 / 0.98	13 / 0.98	7 / 0.97	2 / 0.97	NR	NR	NR	NR	NR	NR	NR	NR	NR
5.3 KW [1.5 Ton] **SEE NOTE 3	6.35 [1/4]	15.88 [5/8]	N/A	8 / 1.00	15 / 0.99	19 / 0.98	13 / 0.98	7 / 0.97	2 / 0.97	NR	NR	NR	NR	NR	NR	NR	NR	NR
	7.94 [5/16]	15.88 [5/8]	68	8 / 1.00	15 / 0.99	23 / 0.98	30 / 0.98	28 / 0.97	27 / 0.97	25 / 0.96	24 / 0.96	22 / 0.95	21 / 0.94	21 / 0.94	21 / 0.94	21 / 0.94	21 / 0.94	21 / 0.94
	9.53 [3/8]	15.88 [5/8]	45	8 / 1.00	15 / 0.99	23 / 0.98	30 / 0.98	30 / 0.97	30 / 0.97	30 / 0.97	30 / 0.96	30 / 0.95	30 / 0.94	30 / 0.94	30 / 0.94	30 / 0.94	30 / 0.94	30 / 0.94
7.0 KW [2 Ton]	6.35 [1/4]	19.05 [3/4]**	N/A	8 / 1.00	15 / 1.00	19 / 0.99	13 / 0.99	7 / 0.99	2 / 0.99	NR	NR	NR	NR	NR	NR	NR	NR	NR
	7.94 [5/16]	19.05 [3/4]**	68	8 / 1.00	15 / 1.00	23 / 0.99	30 / 0.99	28 / 0.99	27 / 0.99	25 / 0.99	24 / 0.98	22 / 0.98	21 / 0.98	21 / 0.98	21 / 0.98	21 / 0.98	21 / 0.98	21 / 0.98
	9.53 [3/8]	19.05 [3/4]**	Metric	8 / 1.00	15 / 1.00	23 / 0.99	30 / 0.99	30 / 0.99	30 / 0.99	30 / 0.99	30 / 0.98	30 / 0.98	30 / 0.98	30 / 0.98	30 / 0.98	30 / 0.98	30 / 0.98	30 / 0.98
8.8 KW [2.5 Ton]	6.35 [1/4]	15.88 [5/8]	N/A	8 / 0.99	15 / 0.98	6 / 0.97	NR	NR	NR	NR	NR	NR	NR	NR	NR	NR	NR	NR
	7.94 [5/16]	15.88 [5/8]	59	8 / 0.99	15 / 0.98	23 / 0.97	27 / 0.96	23 / 0.95	21 / 0.94	19 / 0.93	16 / 0.92	14 / 0.91	11 / 0.90	11 / 0.90	11 / 0.90	11 / 0.90	11 / 0.90	11 / 0.90
	9.53 [3/8]	15.88 [5/8]	39	8 / 0.99	15 / 0.98	23 / 0.97	30 / 0.96	30 / 0.95	30 / 0.94	30 / 0.93	29 / 0.92	28 / 0.91	27 / 0.90	27 / 0.90	27 / 0.90	27 / 0.90	27 / 0.90	27 / 0.90
10.6 KW [3 Ton]	6.35 [1/4]	19.05 [3/4]	N/A	8 / 1.00	15 / 1.00	6 / 0.99	NR	NR	NR	NR	NR	NR	NR	NR	NR	NR	NR	NR
	7.94 [5/16]	19.05 [3/4]	59	8 / 1.00	15 / 1.00	23 / 0.99	27 / 0.99	23 / 0.98	21 / 0.98	18 / 0.93	15 / 0.91	14 / 0.91	11 / 0.90	11 / 0.90	11 / 0.90	11 / 0.90	11 / 0.90	11 / 0.90
	9.53 [3/8]	19.05 [3/4]	36	8 / 1.00	15 / 0.99	23 / 0.99	30 / 0.99	30 / 0.99	30 / 0.98	30 / 0.98	29 / 0.97	28 / 0.97	27 / 0.96	27 / 0.96	27 / 0.96	27 / 0.96	27 / 0.96	27 / 0.96
12.3 KW [3.5 Ton]	6.35 [1/4]	15.88 [5/8]	N/A	8 / 0.99	15 / 0.97	20 / 0.94	15 / 0.92	10 / 0.90	NR	NR	NR	NR	NR	NR	NR	NR	NR	NR
	7.94 [5/16]	15.88 [5/8]	26	8 / 0.99	15 / 0.97	23 / 0.94	29 / 0.92	27 / 0.90	NR	NR	NR	NR	NR	NR	NR	NR	NR	NR
	9.53 [3/8]	19.05 [3/4]	39	8 / 1.00	15 / 0.99	20 / 0.98	15 / 0.98	10 / 0.97	5 / 0.96	NR	NR	NR	NR	NR	NR	NR	NR	NR
12.70 [1/2]	6.35 [1/4]	19.05 [3/4]	26	8 / 1.00	15 / 0.99	23 / 0.98	29 / 0.98	27 / 0.97	26 / 0.96	26 / 0.96	26 / 0.96	26 / 0.96	26 / 0.96	26 / 0.96	26 / 0.96	26 / 0.96	26 / 0.96	26 / 0.96
	7.94 [5/16]	19.05 [3/4]	13	8 / 1.00	15 / 0.99	23 / 0.98	30 / 0.98	30 / 0.97	30 / 0.96	30 / 0.96	30 / 0.95	30 / 0.94	30 / 0.93	30 / 0.93	30 / 0.93	30 / 0.93	30 / 0.93	30 / 0.93
	9.53 [3/8]	22.23 [7/8]	39	8 / 1.00	15 / 1.00	20 / 1.00	15 / 0.99	10 / 0.99	5 / 0.99	NR	NR	NR	NR	NR	NR	NR	NR	NR
12.70 [1/2]	6.35 [1/4]	22.23 [7/8]	26	8 / 1.00	15 / 1.00	23 / 1.00	23 / 1.00	27 / 0.99	26 / 0.99	26 / 0.99	26 / 0.99	26 / 0.99	26 / 0.99	26 / 0.99	26 / 0.99	26 / 0.99	26 / 0.99	26 / 0.99
	7.94 [5/16]	22.23 [7/8]	13	8 / 1.00	15 / 1.00	23 / 1.00	23 / 1.00	30 / 0.99	30 / 0.99	30 / 0.99	30 / 0.99	30 / 0.98	30 / 0.98	30 / 0.98	30 / 0.98	30 / 0.98	30 / 0.98	30 / 0.98
	9.53 [3/8]	19.05 [3/4]	31	8 / 0.99	15 / 0.98	23 / 0.97	27 / 0.96	24 / 0.95	22 / 0.94	20 / 0.92	17 / 0.91	15 / 0.90	15 / 0.90	15 / 0.90	15 / 0.90	15 / 0.90	15 / 0.90	15 / 0.90
12.70 [1/2]	6.35 [1/4]	22.23 [7/8]	15	8 / 0.99	15 / 0.98	23 / 0.97	23 / 0.97	30 / 0.95	30 / 0.94	30 / 0.94	30 / 0.94	30 / 0.94	30 / 0.94	30 / 0.94	30 / 0.94	30 / 0.94	30 / 0.94	30 / 0.94
	7.94 [5/16]	22.23 [7/8]	31	8 / 1.00	15 / 1.00	23 / 0.99	27 / 0.99	24 / 0.99	22 / 0.98	20 / 0.97	17 / 0.97	15 / 0.96	13 / 0.96	13 / 0.96	13 / 0.96	13 / 0.96	13 / 0.96	13 / 0.96
	9.53 [3/8]	22.23 [7/8]	15	8 / 1.00	15 / 1.00	23 / 0.99	23 / 0.99	30 / 0.99	30 / 0.99	30 / 0.99	30 / 0.99	30 / 0.99	30 / 0.99	30 / 0.99	30 / 0.99	30 / 0.99	30 / 0.99	30 / 0.99

NOTES:

- 1) Do not exceed 200 ft linear line length.
- 2) *Do not exceed 100 ft vertical separation if outdoor unit is above indoor unit.
- 3) **3/4" suction line should only be used for 1.5 ton systems if outdoor unit is below or at same level as indoor to assure proper oil return.
- 4) Always use the smallest liquid line allowable to minimize refrigerant charge.
- 5) Applications shaded in light gray indicate capacity multipliers between 0.90 and 0.96 which are not recommended, but are allowed.
- 6) Applications shaded in dark gray are not recommended due to excessive liquid or suction pressure drop.

Refrigerant Line Size Information (Con't.)

14.3 SEER2 Single-Stage Air-Conditioners													
Unit Size	Allowable Liquid Line Size mm [in.]	Allowable Suction Line Size mm [in.]	Apply Long Line Guidelines if Linear Line Length Exceeds Those Shown Below (Feet)	Equivalent Length (Meters)							226-250		
				< 25	26-50	51-75	76-100	101-125	126-150	151-175		176-200	201-225
				Maximum Vertical Rise (Outdoor Unit Below Indoor Unit) * / Capacity Multiplier									
14.1 KW [4 Ton]	9.53 [3/8]	19.05 [3/4]	34	8 / 0.99	15 / 0.98	23 / 0.96	24 / 0.95	20 / 0.93	17 / 0.92	14 / 0.91	NR	NR	NR
	12.7 [1/2]	19.05 [3/4]	17	8 / 0.99	15 / 0.98	23 / 0.96	30 / 0.95	30 / 0.93	30 / 0.92	30 / 0.91	NR	NR	NR
	9.53 [3/8]	22.23 [7/8]	34	8 / 1.00	15 / 0.99	23 / 0.99	24 / 0.98	20 / 0.97	17 / 0.97	14 / 0.96	11 / 0.96	8 / 0.95	5 / 0.95
	12.7 [1/2]	22.23 [7/8]	17	8 / 1.00	15 / 0.99	23 / 0.99	30 / 0.98	30 / 0.97	30 / 0.97	30 / 0.96	30 / 0.96	30 / 0.95	30 / 0.95
17.6 KW [5 Ton]	9.53 [3/8]	19.05 [3/4]	0	8 / 0.99	15 / 0.97	23 / 0.94	19 / 0.92	14 / 0.90	NR	NR	NR	NR	NR
	12.7 [1/2]	19.05 [3/4]	0	8 / 0.99	15 / 0.97	23 / 0.94	30 / 0.92	30 / 0.90	NR	NR	NR	NR	NR
	9.53 [3/8]	22.23 [7/8]	0	8 / 1.00	15 / 0.99	23 / 0.98	19 / 0.97	14 / 0.96	10 / 0.95	5 / 0.94	NR	NR	NR
	12.7 [1/2]	22.23 [7/8]	0	8 / 1.00	15 / 0.99	23 / 0.98	30 / 0.97	30 / 0.96	30 / 0.95	30 / 0.94	29 / 0.94	28 / 0.93	27 / 0.92
	9.53 [3/8]	28.58 [1-1/8]	0	8 / 1.01	15 / 1.01	23 / 1.00	19 / 1.00	14 / 0.99	10 / 0.99	5 / 0.99	NR	NR	NR
	12.7 [1/2]	28.58 [1-1/8]	0	8 / 1.01	15 / 1.01	23 / 1.00	30 / 1.00	30 / 0.99	30 / 0.99	30 / 0.99	29 / 0.99	28 / 0.99	27 / 0.98

NOTES:

- 1) Do not exceed 200 ft linear line length.
- 2) *Do not exceed 100 ft vertical separation if outdoor unit is above indoor unit.
- 3) **3/4" suction line should only be used for 1.5 ton systems if outdoor unit is below or at same level as indoor to assure proper oil return.
- 4) Always use the smallest liquid line allowable to minimize refrigerant charge.
- 5) Applications shaded in light gray indicate capacity multipliers between 0.90 and 0.96 which are not recommended, but are allowed.
- 6) Applications shaded in dark gray are not recommended due to excessive liquid or suction pressure drop.

Performance Data @ AHRI Standard Conditions – Cooling

Designated Tested Combination (DTC)							
Outdoor Unit	Indoor Coil	Total Capacity BTU/H [kW]	Net Sensible BTU/H [kW]	Net Latent BTU/H [kW]	SEER2	EER2	Indoor CFM [L/s]
WA14AZ18AJ1	RCFZ2417STAN	17600 [5.2]	13500 [4.0]	4100 [1.2]	14.3	11.7	600 [283.2]
WA14AZ24AJ1	RCFZ2417STAN	22800 [6.7]	17500 [5.1]	5300 [1.6]	14.3	11.7	725 [342.2]
WA14AZ30AJ1	RCFZ3617STAN	28800 [8.4]	22100 [6.5]	6700 [2.0]	14.3	11.7	900 [424.8]
WA14AZ36AJ1	RCFZ3617STAN	34200 [10.0]	26200 [7.7]	8000 [2.3]	14.3	11.7	1025 [483.7]
WA14AZ42AJ1	RCFZ4821STAN	38500 [11.3]	29500 [8.6]	9000 [2.6]	14.3	11.7	1300 [613.5]
WA14AZ48AJ1	RCFZ4821STAN	45000 [13.2]	34500 [10.1]	10500 [3.1]	13.8	11.2	1425 [672.5]
WA14AZ60AJ1	RCFZ6024STAN	56000 [16.4]	42900 [12.6]	13100 [3.8]	13.8	11.2	1600 [755.1]

NOTE: This data includes DTC (Designated Test Combination) ratings and is for reference purposes only. A full listing of official ratings and system match-ups, along with downloadable certificates, can be accessed from the AHRI website: www.ahrirectory.org.

[] Designates Metric Conversions



The new degree of comfort.®

PRELIMINARY

Endeavor™ Line Select® Series iC Air Conditioners



This product meets a stringent set of our internally defined sustainability standards

WA15AZ

Cooling Efficiencies up to: 15.2 SEER2/9.8 EER2

Nominal Sizes: 2 to 5 Ton [7.0 to 17.6 kW]

Cooling Capacities: 17.1 to 55.5 kBTU [5.0 to 16.3 kW]



Table of Contents

Features & Benefits	3
Model Number Identification	4
General Data/Electrical Data	5
Accessories	6
Weighted Sound Power	6
Unit Dimensions	7
Clearances	8
Control Wiring	9
Application Guidelines.....	9
Refrigerant Line Size Information	10
Performance Data	11
Limited Warranty	12

Features and Benefits

- **Bluetooth Connectivity:** With the Rheem Contractor App, built-in technology makes advanced set-up, monitoring, troubleshooting and repairing the product easier than ever before
- **Variable Speed Twin Rotary Compressor & Inverter Drive:**
 - 3+ Stage Operation when installed with a 24V two-stage thermostat
 - Provides precise temperature control, advanced humidity control and greater efficiency
- **Swept Wing Fan Technology:** Features quieter operation and improved unit acoustics
- **7 mm Condenser Copper Coil:** Requires less refrigerant allowing for a smaller and lighter footprint while enhancing reliability
- **Pre-Painted Louvered Steel Cabinet:** Features durable construction to add protection from yard hazards, weather corrosion
- **Easily Accessible Control Box:** Leads to ease of installation and future serviceability

Air Conditioners

<u>W</u>	<u>A</u>	<u>15</u>	<u>A</u>	<u>Z</u>	<u>24</u>	<u>A</u>	<u>J</u>	<u>3</u>	<u>N</u>	<u>A</u>
Brand	Product Category	SEER2	Region	Refrigerant	Capacity BTU/HR	Major Series	Voltage	Type	Controls	Minor Series
W - Rheem Select	A - Air Conditioners	15 - 15.2 SEER2	A - All	Z - R-410A	24 - 24,000 [7.03 kW] 36 - 36,000 [10.55 kW] 48 - 48,000 [14.07 kW] 60 - 60,000 [17.58 kW]	A - 1st Design	J - 208/230/1/60	3 - 3+ Stage	N - Non-Communicating	A - 1st Design

[] Designates Metric Conversions

AVAILABLE MODELS	DESCRIPTION
WA15AZ24AJ3NA	Endeavor™ Line <i>Select</i> ® Series 2 ton 3+ Speed iM Air Conditioner – 208/230/1/60
WA15AZ36AJ3NA	Endeavor™ Line <i>Select</i> ® Series 3 ton 3+ Speed iM Air Conditioner – 208/230/1/60
WA15AZ48AJ3NA	Endeavor™ Line <i>Select</i> ® Series 4 ton 3+ Speed iM Air Conditioner – 208/230/1/60
WA15AZ60AJ3NA	Endeavor™ Line <i>Select</i> ® Series 5 ton 3+ Speed iM Air Conditioner – 208/230/1/60

STANDARD EQUIPMENT
R-410A Refrigerant
Twin Rotary Compressor
Field Installed Filter Drier
Front Seating Service Valves
Internal Pressure Relief Valve
Internal Thermal Overload
Long Line capability
Low Ambient capability with Kit
Optimized Venturi Airflow
Rust resistant screws
QR code
External gauge ports

General Data				
MODEL NO.	WA15AZ24AJ3	WA15AZ36AJ3	WA15AZ48AJ3	WA15AZ60AJ3
Nominal Tonnage	2.0	3.0	4.0	5.0
Valve Connections				
Liquid Line O.D. – in.	3/8	3/8	3/8	3/8
Suction Line O.D. – in.	3/4	3/4	7/8	7/8
Refrigerant (R410A) furnished oz.¹	91	119	130	154
Compressor Type	Twin Rotary			
Outdoor Coil				
Net face area – Outer Coil	11.79	14.4	16.42	17.88
Net face area – Inner Coil	—	—	—	—
Tube diameter – in.	0.276	0.276	0.276	0.276
Number of rows	1	1	1	1
Fins per inch	24	24	24	24
Outdoor Fan				
Diameter – in.	20	24	24	26
Number of blades	3	3	3	3
Motor hp	1/5	1/5	1/3	1/2
CFM	2908	4138	4529	5274
RPM	1075	1000	1075	1075
watts	170	267	294	370
Shipping weight – lbs.	COMING SOON			
Operating weight – lbs.				
Electrical Data				
Line Voltage Data (Volts-Phase-Hz)	208/230-1-60	208/230-1-60	208/230-1-60	208/230-1-60
Maximum overcurrent protection (amps)²	20	30	40	50
Minimum circuit ampacity³	12	20	25	32
Compressor				
Rated load amps	10	15	20	25
Locked rotor amps	65	70	96	119

¹Refrigerant charge sufficient for 15 ft. length of refrigerant lines. For longer line set requirements see the installation instructions for information about set length and additional refrigerant charge required.

²HACR type circuit breaker or fuse.

³Refer to National Electrical Code manual to determine wire, fuse and disconnect size requirements.

Accessories

MODEL NO.		WA15AZ24AJ3	WA15AZ36AJ3	WA15AZ48AJ3	WA15AZ60AJ3
Compressor crankcase heater*		N/A	N/A	N/A	N/A
Low ambient control		47-102709-10	47-102709-10	47-102709-10	47-102709-10
Compressor sound cover		68-23427-27	68-23427-28	68-23427-29	68-23427-29
Low pressure control		47-103454-01	47-103454-01	47-103454-01	47-103454-01
High pressure control		47-103669-02	47-103669-02	47-103669-02	47-103669-02
Liquid Line Solenoid (24 VAC, 50/60 Hz)	Solenoid Valve	200RD2T3TVLC	200RD2T3TVLC	200RD2T3TVLC	200RD2T3TVLC
	Solenoid Coil	61-AMG24V	61-AMG24V	61-AMG24V	61-AMG24V
Liquid Line Solenoid (120/240 VAC, 50/60 Hz)	Solenoid Valve	200RD2T3TVLC	200RD2T3TVLC	200RD2T3TVLC	200RD2T3TVLC
	Solenoid Coil	61-AMG120/240V	61-AMG120/240V	61-AMG120/240V	61-AMG120/240V

*Crankcase Heater recommended with Low Ambient Kit.

Weighted Sound Power Level (dBA)

Unit Size - Voltage, Series	Standard Rating (dBA) Low Speed/ High Speed	TYPICAL OCTAVE BAND SPECTRUM (dBA without tone adjustment)							Sound Power
		125	250	500	1000	2000	4000	8000	
WA15AZ24AJ3	63.3	35.9	47.9	55.3	53.2	50.4	47.1	43.8	Sound Blankets – Standard
	71.7	46.1	59.1	63.2	60.8	58.7	56.5	47.9	
WA15AZ36AJ3	61.4	38.5	48.0	53.8	49.2	45.9	47.0	47.4	
	72.9	47.5	59.5	64.9	60.7	62.6	57.0	49.6	
WA15AZ48AJ3	63.8	42.3	45.9	53.5	48.9	45.8	59.1	36.4	
	76.2	49.4	61.4	68.1	53.9	60.8	57.4	48.5	
WA15AZ60AJ3	65.7	39.7	49.0	58.2	54.5	52.2	53.8	41.3	
	76.7	49.3	64.6	68.1	65.1	62.6	58.6	53.0	

NOTE: Tested in accordance with AHRI Standard 270-08 (not listed in AHRI)

Unit Dimensions

MODEL NO.	OPERATING						SHIPPING					
	H (Height)		L (Length)		W (Width)		H (Height)		L (Length)		W (Width)	
	INCHES	mm	INCHES	mm	INCHES	mm	INCHES	mm	INCHES	mm	INCHES	mm
WA15AZ24AJ3	27.17	690	29.54	750	29.54	750	29.06	738	32.63	829	32.63	829
WA15AZ36AJ3	27.17	690	33.66	855	33.66	855	29.06	738	36.63	930	36.63	930
WA15AZ48AJ3	31.17	792	33.66	855	33.66	855	33.06	840	36.63	930	36.63	930
WA15AZ60AJ3	31.17	792	35.54	903	35.54	903	33.06	840	38.63	981	38.63	981

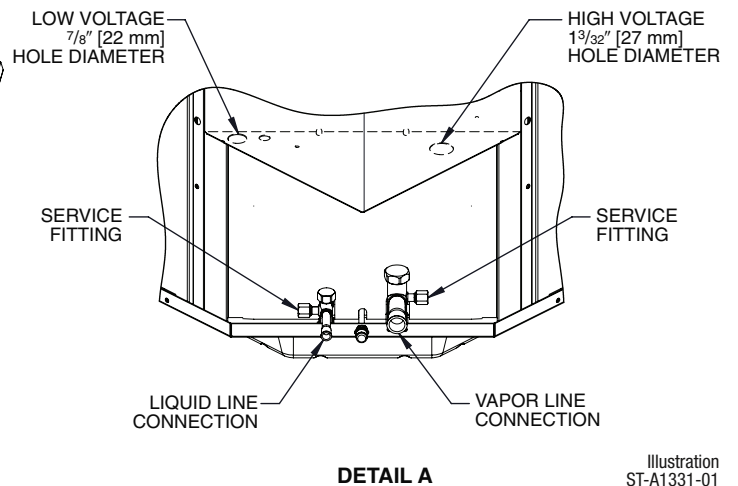
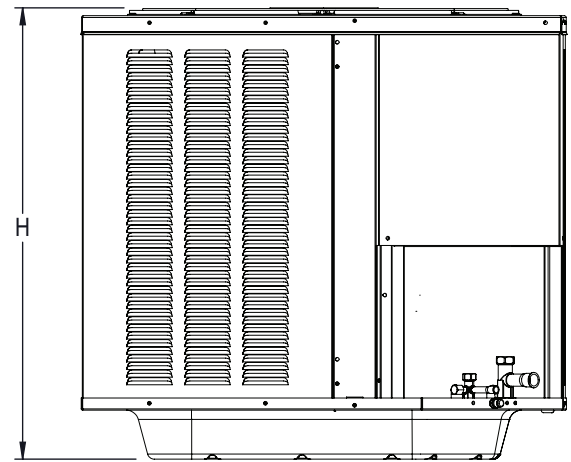
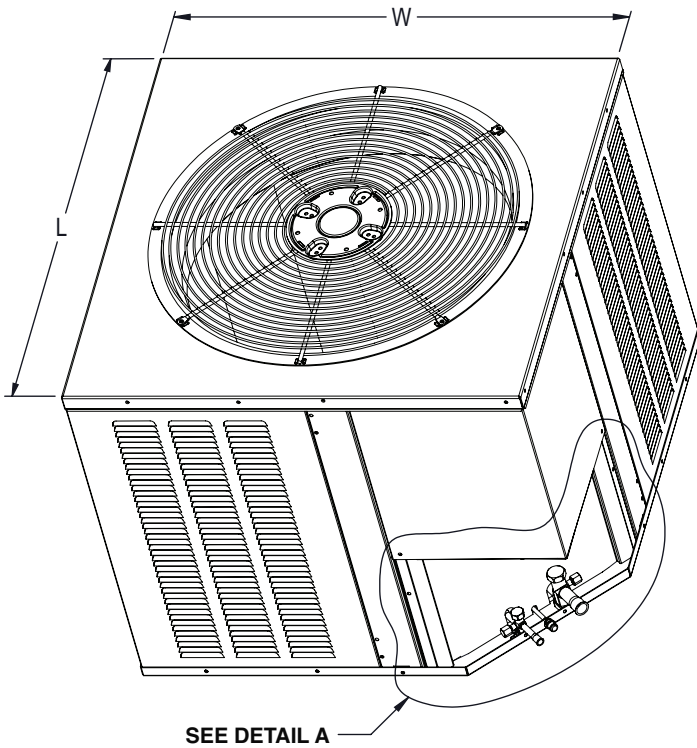
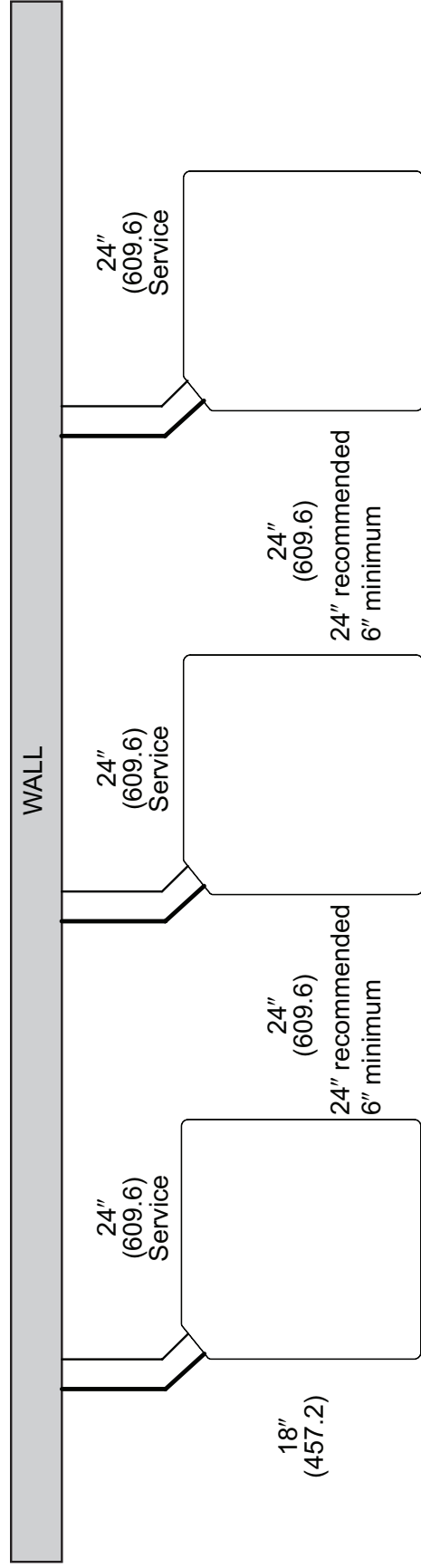
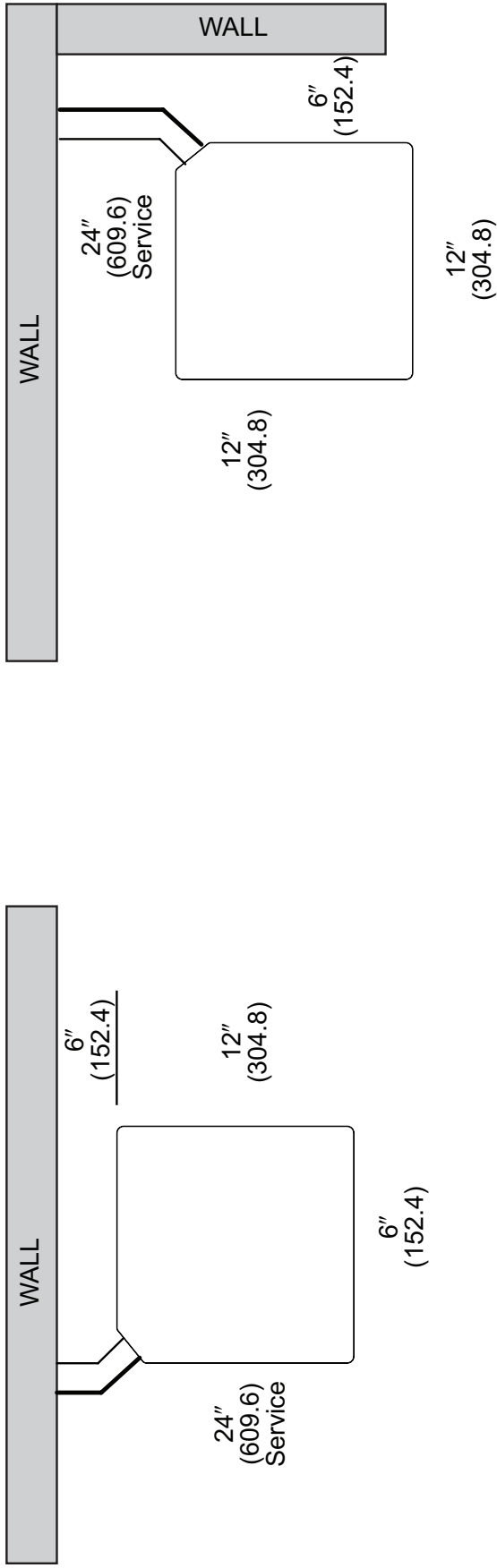

Illustration
ST-A1331-01
Rev. 10-20-2022

NOTE: Illustrations show the deep drawn basepan.

[] Designates Metric Conversions

CLEARANCES



NOTE: NUMBERS IN () = mm

IMPORTANT: When installing multiple units in an alcove, roof well or partially enclosed area, ensure there is adequate ventilation to prevent re-circulation of discharge air.

Control Wiring

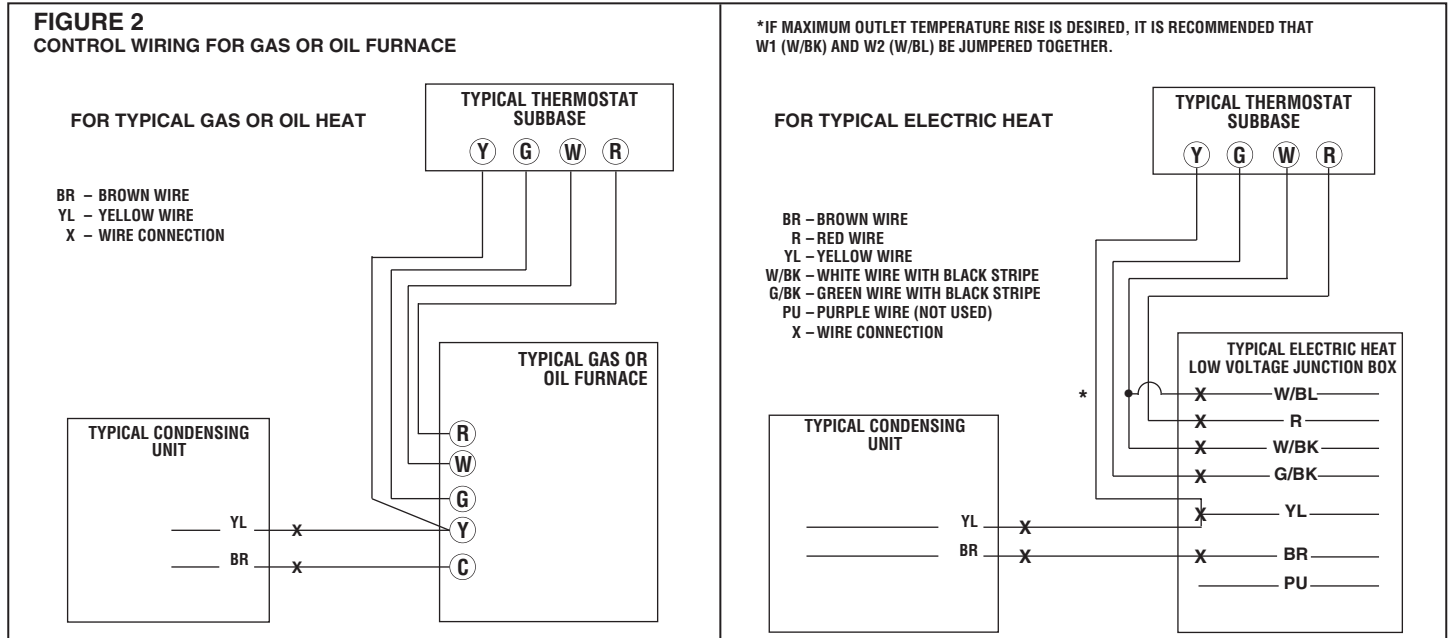

Application Guidelines

1. Intended for outdoor installation with free air inlet and outlet. Outdoor fan external static pressure available is less than 0.01 -in. wc.
2. Minimum outdoor operation air temperature for cooling mode without low-ambient operation accessory is 55°F (12.8°C).
3. Maximum outdoor operating air temperature is 125°F (51.7°C).
4. For reliable operation, unit should be level in all horizontal planes.
5. Use only copper wire for electric connections at unit. Aluminum and clad aluminum are not acceptable for the type of connector provided.
6. Do not apply capillary tube indoor coils to these units.
7. Factory-supplied filter drier must be installed.

Refrigerant Line Size Information

15/16 SEER2 VARIABLE SPEED AIR CONDITIONERS								
Unit Size	Allowable Liquid Line Size	Allowable Vapor Line Size	Outdoor Unit ABOVE or BELOW Indoor Unit Equivalent Length (Feet)					
			< 25	26-50	51-75	76-100	101-125	126-150
			Maximum Vertical Separation / Capacity Multiplier					
2.0 Ton **SEE NOTE 3	1/4"	5/8"	25/1.00	50/0.99	32/0.98	40/0.97	NR	NR
	5/16"	5/8"	25/1.00	50/0.99	50/0.98	50/0.97	50/0.96	50/0.95
	3/8"	5/8"	25/1.00	50/0.99	50/0.98	50/0.97	50/0.96	50/0.95
	1/4"	3/4"	25/1.00	50/1.00	32/0.99	40/0.99	NR	NR
	5/16"	3/4"	25/1.00	50/1.00	50/0.99	50/0.99	50/0.99	50/0.98
	3/8"	3/4"	25/1.00	50/1.00	50/0.99	50/0.99	50/0.99	50/0.98
3 Ton	5/16"	5/8"	25/0.99	50/0.97	50/0.95	50/0.93	37/0.91	NR
	3/8"	5/8"	25/0.99	50/0.97	50/0.95	50/0.93	50/0.91	NR
	5/16"	3/4"	25/1.00	50/0.99	50/0.99	50/0.98	37/0.97	22/0.96
	3/8"	3/4"	25/1.00	50/0.99	50/0.99	50/0.98	50/0.97	50/0.96
	1/2"	3/4"	25/1.00	50/0.99	50/0.99	50/0.98	50/0.97	50/0.96
4 Ton	3/8"	3/4"	25/0.99	50/0.98	50/0.97	50/0.96	50/0.94	50/0.93
	1/2"	3/4"	25/0.99	50/0.98	50/0.97	50/0.96	50/0.94	50/0.93
	3/8"	7/8"	25/1.00	50/0.99	50/0.99	50/0.98	50/0.98	50/0.97
	1/2"	7/8"	25/1.00	50/0.99	50/0.99	50/0.98	50/0.98	50/0.97
5 Ton	3/8"	3/4"	25/0.99	50/0.97	50/0.95	50/0.93	50/0.91	NR
	1/2"	3/4"	25/0.99	50/0.97	50/0.95	50/0.93	50/0.91	NR
	3/8"	7/8"	25/1.00	50/0.99	50/0.98	50/0.98	50/0.97	38/0.96
	1/2"	7/8"	25/1.00	50/0.99	50/0.98	50/0.98	50/0.97	50/0.96

NOTES:

- 1) Do not exceed 150 ft. linear line length.
- 2) *Do not exceed 50 ft. vertical separation between indoor and outdoor units.
- 3) **3/4" suction line should only be used for 2 ton systems if outdoor unit is below or at same level as indoor unit to assure proper oil return.
- 4) Always use the smallest liquid line allowable to minimize refrigerant charge.
- 5) Applications shaded in light gray indicate capacity multipliers between 0.90 and 0.96 which are not recommended, but are allowed.
- 6) Applications shaded in dark gray are not recommended due to excessive liquid or suction pressure drop.

[] Designates Metric Conversions

Refrigerant Line Size Information (Con't.)

15/16 SEER2 VARIABLE SPEED AIR CONDITIONERS								
Unit Size	Allowable Liquid Line Size	Allowable Vapor Line Size	Outdoor Unit ABOVE or BELOW Indoor Unit Equivalent Length (Meters)					
			< 8	8-15	16-23	23-31	31-38	38-46
			Maximum Vertical Separation / Capacity Multiplier					
2.0 Ton **SEE NOTE 3	6.35 [1/4]	15.88 [5/8]	8/1.00	15/0.99	10/0.98	10/0.97	NR	NR
	7.94 [5/16]	15.88 [5/8]	8/1.00	15/0.99	15/0.98	15/0.97	15/0.96	15/0.95
	9.53 [3/8]	15.88 [5/8]	8/1.00	15/0.99	15/0.98	15/0.97	15/0.96	15/0.95
	6.35 [1/4]	19.05 [3/4]**	8/1.00	15/0.99	10/0.99	12/0.99	NR	NR
	7.94 [5/16]	19.05 [3/4]**	8/1.00	15/0.99	15/0.99	15/0.99	15/0.99	15/0.98
	9.53 [3/8]	19.05 [3/4]**	8/1.00	15/0.99	15/0.99	15/0.99	15/0.99	15/0.98
3 Ton	7.94 [5/16]	15.88 [5/8]	8/0.99	15/0.97	15/0.95	15/0.93	11/0.91	NR
	9.53 [3/8]	15.88 [5/8]	8/0.99	15/0.97	15/0.95	15/0.93	15/0.91	NR
	7.94 [5/16]	19.05 [3/4]	8/1.00	15/0.99	15/0.99	15/0.98	11/0.97	7/0.96
	9.53 [3/8]	19.05 [3/4]	8/1.00	15/0.99	15/0.99	15/0.98	15/0.97	15/0.96
	12.7 [1/2]	19.05 [3/4]	8/1.00	15/0.99	15/0.99	15/0.98	15/0.97	15/0.96
4 Ton	9.53 [3/8]	19.05 [3/4]	8/0.99	15/0.98	15/0.97	15/0.96	15/0.94	15/0.93
	12.7 [1/2]	19.05 [3/4]	8/0.99	15/0.98	15/0.97	15/0.96	15/0.94	15/0.93
	9.53 [3/8]	22.23 [7/8]	8/1.00	15/0.99	15/0.99	15/0.98	15/0.98	15/0.97
	12.7 [1/2]	22.23 [7/8]	8/1.00	15/0.99	15/0.99	15/0.98	15/0.98	15/0.97
5 Ton	9.53 [3/8]	19.05 [3/4]	8/0.99	15/0.97	15/0.95	15/0.93	15/0.91	NR
	12.7 [1/2]	19.05 [3/4]	8/0.99	15/0.97	15/0.95	15/0.93	15/0.91	NR
	9.53 [3/8]	22.23 [7/8]	8/1.00	15/0.99	15/0.98	15/0.98	15/0.97	12/0.96
	12.7 [1/2]	22.23 [7/8]	8/1.00	15/0.99	15/0.98	15/0.98	15/0.97	15/0.97

NOTES:

- 1) Do not exceed 46 meters linear line length.
- 2) *Do not exceed 15 meters vertical separation between indoor and outdoor units.
- 3) **19.05mm [3/4 in.] vapor line should only be used for 2 ton systems if outdoor unit is below or at same level as indoor unit to assure proper oil return.
- 4) Always use the smallest liquid line allowable to minimize refrigerant charge.
- 5) Applications shaded in light gray indicate capacity multipliers between 0.90 and 0.96 which are not recommended, but are allowed.
- 6) Applications shaded in dark gray are not recommended due to excessive liquid or suction pressure drop.

Additional Oil, Oz.											
Lineset Length	50	60	70	80	90	100	110	120	130	140	150
2T	N/A	N/A	N/A	N/A	N/A	1	2	3	5	6	7
3T	N/A	N/A	N/A	N/A	N/A	N/A	1	2	3	5	6
4T	N/A	N/A	N/A	N/A	N/A	N/A	N/A	N/A	N/A	N/A	N/A
5T	N/A	N/A	N/A	N/A	N/A	N/A	N/A	N/A	N/A	N/A	N/A

Performance Data @ AHRI Standard Conditions – Cooling

Designated Tested Combination (DTC)							
Outdoor Unit	Air Handler	Total Capacity BTU/H [kW]	Net Sensible BTU/H [kW]	Net Latent BTU/H [kW]	SEER2	EER2	Indoor CFM [L/s]
WA15AZ24AJ3	RH3VZ2417STACN	22,800 [6.7]	17,600 [5.2]	5,200 [1.5]	15.2	9.8	750 [354.0]
WA15AZ36AJ3	RH3VZ3617STACN	34,200 [10.0]	26,600 [7.8]	7,600 [2.2]	15.2	9.8	1,125 [530.9]
WA15AZ48AJ3	RH3VZ4821STACN	45,500 [13.3]	35,500 [10.4]	10,000 [2.9]	15.2	9.8	1,425 [672.5]
WA15AZ60AJ3	RH3VZ6024STACN	55,500 [16.3]	43,000 [12.6]	12,500 [3.7]	15.2	9.8	1,675 [790.5]

NOTE: This data includes DTC (Designated Test Combination) ratings and is for reference purposes only. A full listing of official ratings and system match-ups, along with downloadable certificates, can be accessed from the AHRI website: www.ahridirectory.org.

[] Designates Metric Conversions



The new degree of comfort.®

Endeavor™ Line Classic® Series iM Air Conditioners



RA14AZ

Cooling Efficiency up to: 16 SEER2/13 EER2

Nominal Sizes: 1½ to 5 Ton [5.28 to 17.6 kW]

Cooling Capacities: 17.1 to 55.5 kBTU [5.0 to 16.3 kW]



† A.F.U.E. (Annual Fuel Utilization Efficiency) calculated in accordance with Department of Energy test procedures.

****Proper sizing and installation of equipment is critical to achieve optimal performance. Split system air conditioners and heat pumps must be matched with appropriate coil components to meet Energy Star. Ask your Contractor for details or visit www.energystar.gov.***

Table of Contents

Features & Benefits.....	3
Model Number Identification.....	4
General Data/Electrical Data.....	5
Accessories.....	6
Weighted Sound Power.....	6
Unit Dimensions.....	7
Clearances.....	8
Control Wiring.....	9
Refrigerant Line Size Information.....	10-13
Performance Data.....	14
Limited Warranty.....	16

Features and Benefits

- **Lighter Footprint & Less Environmental Impact from New 7mm Condenser Coil:** provided by a decrease in refrigerant requirements and an overall weight reduction
- **Efficient Cooling:** up to 16 SEER2/13 EER2
- **PlusOne Expanded Value Space:** 3in. – 4in. – 5 in. service valve space – provides a minimum working area of 27-square inches for easier access
- **PlusOne Triple Service Access:** 15 in. wide, industry leading corner service access – makes repairs easier and faster. The two fastener, removable corner allows optimal access to internal unit components. Individual louver panels come out once fastener is removed, for faster coil cleaning and easier cabinet reassembly
- **System Matching Simplicity:** matches to all tiers of gas furnaces
- **Modern Cabinet Aesthetics:** High curb appeal with visually appealing design
- **Curved Louver Panels:** provide ultimate coil protection, enhance cabinet strength, and increased cabinet rigidity
- **Diagnostic Service Window:** with two-fastener opening – provides access to the high and low pressure
- **External Gauge Port Access:** allows easy connection of “low-loss” gauge ports
- **QR Code:** provides technical information on demand for faster service calls
- **Fan Motor Harness:** with extra-long wires allows unit top to be removed without disconnecting fan wire

Air Conditioners

<u>R</u>	<u>A</u>	<u>14</u>	<u>A</u>	<u>Z</u>	<u>24</u>	<u>A</u>	<u>J</u>	<u>1</u>	<u>N</u>	<u>A</u>	<u>LHP</u>
Brand	Product Category	SEER2	Region	Refrigerant	Capacity BTU/HR	Major Series	Voltage	Type	Controls	Minor Series	Option Code
Rheem	A - Air Conditioners	13.8/14.3 SEER2	A - All	Z - R-410A	18 - 18,000 [5.28 kW] 24 - 24,000 [7.03 kW] 30 - 30,000 [8.79 kW] 36 - 36,000 [10.55 kW] 42 - 42,000 [12.31 kW] 48 - 48,000 [14.07 kW] 60 - 60,000 [17.58 kW]	A - 1st Design	J - 1ph, 208-230/60	1 - Single Stage	N - Non-Communicating	A - 1st Design	LHP - W/HLPC

[] Designates Metric Conversions

AVAILABLE MODELS	DESCRIPTION
RA14AZ18AJ1NA	Endeavor™ Line <i>Classic</i> ® Series 1 1/2 ton 14.3 SEER2 Single-Stage iM Air Conditioner-208/230/1/60
RA14AZ18AJ1NALHP	Endeavor™ Line <i>Classic</i> ® Series 1 1/2 ton 14.3 SEER2 Single-Stage iM Air Conditioner w/ High/Low Pressure-208/230/1/60
RA14AZ24AJ1NA	Endeavor™ Line <i>Classic</i> ® Series 2 ton 14.3 SEER2 Single-Stage iM Air Conditioner-208/230/1/60
RA14AZ24AJ1NALHP	Endeavor™ Line <i>Classic</i> ® Series 2 ton 14.3 SEER2 Single-Stage iM Air Conditioner w/ High/Low Pressure-208/230/1/60
RA14AZ30AJ1NA	Endeavor™ Line <i>Classic</i> ® Series 2 1/2 ton 14.3 SEER2 Single-Stage iM Air Conditioner-208/230/1/60
RA14AZ30AJ1NALHP	Endeavor™ Line <i>Classic</i> ® Series 2 1/2 ton 14.3 SEER2 Single-Stage iM Air Conditioner w/ High/Low Pressure-208/230/1/60
RA14AZ36AJ1NA	Endeavor™ Line <i>Classic</i> ® Series 3 ton 14.3 SEER2 Single-Stage iM Air Conditioner-208/230/1/60
RA14AZ36AJ1NALHP	Endeavor™ Line <i>Classic</i> ® Series 3 ton 14.3 SEER2 Single-Stage iM Air Conditioner w/ High/Low Pressure-208/230/1/60
RA14AZ42AJ1NA	Endeavor™ Line <i>Classic</i> ® Series 3 1/2 ton 14.3 SEER2 Single-Stage iM Air Conditioner-208/230/1/60
RA14AZ42AJ1NALHP	Endeavor™ Line <i>Classic</i> ® Series 3 1/2 ton 14.3 SEER2 Single-Stage iM Air Conditioner w/ High/Low Pressure-208/230/1/60
RA14AZ48AJ1NA	Endeavor™ Line <i>Classic</i> ® Series 4 ton 14.3 SEER2 Single-Stage iM Air Conditioner-208/230/1/60
RA14AZ48AJ1NALHP	Endeavor™ Line <i>Classic</i> ® Series 4 ton 14.3 SEER2 Single-Stage iM Air Conditioner w/ High/Low Pressure-208/230/1/60
RA14AZ60AJ1NA	Endeavor™ Line <i>Classic</i> ® Series 5 ton 14.3 SEER2 Single-Stage iM Air Conditioner-208/230/1/60
RA14AZ60AJ1NALHP	Endeavor™ Line <i>Classic</i> ® Series 5 ton 14.3 SEER2 Single-Stage iM Air Conditioner w/ High/Low Pressure-208/230/1/60

STANDARD EQUIPMENT
R-410A Refrigerant
Scroll Compressor
Field Installed Filter Drier
Front Seating Service Valves
Internal Pressure Relief Valve
Internal Thermal Overload
Long Line capability
Low Ambient capability with Kit
3-4-5 Expanded Valve Space
Composite Basepan
2 Screw Control Box Access
15" Access to Internal Components
Quick release louver panel design
No fasteners to remove along bottom
Optimized Venturi Airflow
Powder coated paint
Rust resistant screws
QR code
External gauge ports
Service trays

General Data							
GENERAL DATA							
MODEL NO.	RA14AZ18	RA14AZ24	RA14AZ30	RA14AZ36	RA14AZ42	RA14AZ48	RA14AZ60
Nominal Tonnage	1.5	2.0	2.5	3.0	3.5	4.0	5.0
Valve Connections							
Liquid Line O.D. – in.	3/8	3/8	3/8	3/8	3/8	3/8	3/8
Suction Line O.D. – in.	3/4	3/4	3/4	3/4	7/8	7/8	7/8
Refrigerant (R410A) furnished oz.¹	94	115	120	124	149	153	203
Compressor Type	Scroll						
Outdoor Coil							
Net face area – Outer Coil	10.9	13.3	14.3	16.4	19.5	19.5	32.5
Net face area – Inner Coil	10.5	12.9	13.9	15.9	18.8	18.8	—
Tube diameter – in.	0.276	0.276	0.276	0.276	0.276	0.276	0.375
Number of rows	2	2	2	2	2	2	1
Fins per inch	24	24	24	24	24	24	22
Outdoor Fan							
Diameter – in.	20	24	24	24	24	24	26
Number of blades	2	2	2	2	3	3	3
Motor hp	1/7	1/6	1/6	1/6	1/5	1/5	1/3
CFM	2156	2723	2830	2991	3655	3655	5178
RPM	1075	825	825	825	850	850	910
watts	152	161	165	145	214	214	271
Shipping weight – lbs.	151	185	197	217	259	250	294
Operating weight – lbs.	144	178	190	210	252	243	287
Electrical Data							
Line Voltage Data (Volts-Phase-Hz)	208/230-1-60	208/230-1-60	208/230-1-60	208/230-1-60	208/230-1-60	208/230-1-60	208/230-1-60
Maximum overcurrent protection (amps)²	20	25	30	30	40	40	60
Minimum circuit ampacity³	14	18	19	20	24	24	40
Compressor							
Rated load amps	9	12	14	13	18	18	26
Locked rotor amps	43	60	68	83	110	102	150
Condenser Fan Motor							
Full load amps	0.8	0.8	0.8	0.8	1.0	1.0	2.8
Locked rotor amps	1.5	1.5	1.7	1.7	2.6	2.6	—

¹Refrigerant charge sufficient for 15 ft. length of refrigerant lines. For longer line set requirements see the installation instructions for information about set length and additional refrigerant charge required.

²HACR type circuit breaker or fuse.

³Refer to National Electrical Code manual to determine wire, fuse and disconnect size requirements.

Accessories

MODEL NO.	RA14AZ18	RA14AZ24	RA14AZ30	RA14AZ36	RA14AZ42	RA14AZ48	RA14AZ60
Compressor crankcase heater*	44-17402-44	44-17402-44	44-17402-44	44-17402-44	44-17402-45	44-17402-45	44-17402-45
Low ambient control	RXAD-A08	RXAD-A08	RXAD-A08	RXAD-A08	RXAD-A08	RXAD-A08	RXAD-A08
Compressor sound cover	68-23427-26	68-23427-26	68-23427-26	68-23427-26	68-23427-25	68-23427-25	68-23427-25
Compressor hard start kit	SK-A1	SK-A1	SK-A1	SK-A1	SK-A1	SK-A1	SK-A1
Compressor time delay	RXMD-B01	RXMD-B01	RXMD-B01	RXMD-B01	RXMD-B01	RXMD-B01	RXMD-B01
Low pressure control	RXAC-A07	RXAC-A07	RXAC-A07	RXAC-A07	RXAC-A07	RXAC-A07	RXAC-A07
High pressure control	RXAB-A07	RXAB-A07	RXAB-A07	RXAB-A07	RXAB-A07	RXAB-A07	RXAB-A07
Liquid Line Solenoid (24 VAC, 50/60 Hz)	Solenoid Valve	200RD2T3TVLC	200RD2T3TVLC	200RD2T3TVLC	200RD2T3TVLC	200RD2T3TVLC	200RD2T3TVLC
	Solenoid Coil	61-AMG24V	61-AMG24V	61-AMG24V	61-AMG24V	61-AMG24V	61-AMG24V
Liquid Line Solenoid (120/240 VAC, 50/60 Hz)	Solenoid Valve	200RD2T3TVLC	200RD2T3TVLC	200RD2T3TVLC	200RD2T3TVLC	200RD2T3TVLC	200RD2T3TVLC
	Solenoid Coil	61-AMG120/240V	61-AMG120/240V	61-AMG120/240V	61-AMG120/240V	61-AMG120/240V	61-AMG120/240V
Classic Top Cap w/Label	91-101123-21	91-101123-21	91-101123-21	91-101123-21	91-101123-21	91-101123-21	91-101123-21

*Crankcase Heater recommended with Low Ambient Kit.

Weighted Sound Power Level (dBA)

UNIT SIZE- VOLTAGE, SERIES	STANDARD RATING (DBA)	TYPICAL OCTAVE BAND SPECTRUM (dBA without tone adjustment)						
		125	250	500	1000	2000	4000	8000
RA14AZ18	70.7	48.2	56.0	61.9	61.0	56.5	53.5	45.7
RA14AZ24	68.5	44.6	53.6	58.7	58.0	55.5	50.5	45.7
RA14AZ30	70.8	45.1	54.5	59.8	59.0	56.8	53.8	45.9
RA14AZ36	71.6	45.4	52.6	60.2	60.8	58.7	55.9	48.4
RA14AZ42	72.5	46.6	55.3	63.9	62.1	59.4	55.2	48.2
RA14AZ48	74.0	45.4	55.7	64.2	62.9	60.8	56.7	51.2
RA14AZ60	75.8	43.4	59.8	67.2	65.5	62.7	59.2	53.1

NOTE: Tested in accordance with AHRI Standard 270-08 (not listed in AHRI)

Unit Dimensions

MODEL NO.	OPERATING						SHIPPING					
	H (Height)		L (Length)		W (Width)		H (Height)		L (Length)		W (Width)	
	INCHES	mm	INCHES	mm	INCHES	mm	INCHES	mm	INCHES	mm	INCHES	mm
RA14AZ18	25.00	635	29.75	756	29.75	756	26.50	673	32.38	822	32.38	822
RA14AZ24	25.00	635	33.75	857	33.75	857	26.50	673	36.38	924	36.38	924
RA14AZ30	27.00	686	33.75	857	33.75	857	28.50	724	36.38	924	36.38	924
RA14AZ36	31.00	787	33.75	857	33.75	857	32.50	826	36.38	924	36.38	924
RA14AZ42	35.00	889	33.75	857	33.75	857	36.50	927	36.38	924	36.38	924
RA14AZ48	35.00	889	33.75	857	33.75	857	36.50	927	36.38	924	36.38	924
RA14AZ60	51.00	1295	35.75	908	35.75	908	52.50	1334	38.38	975	38.38	975

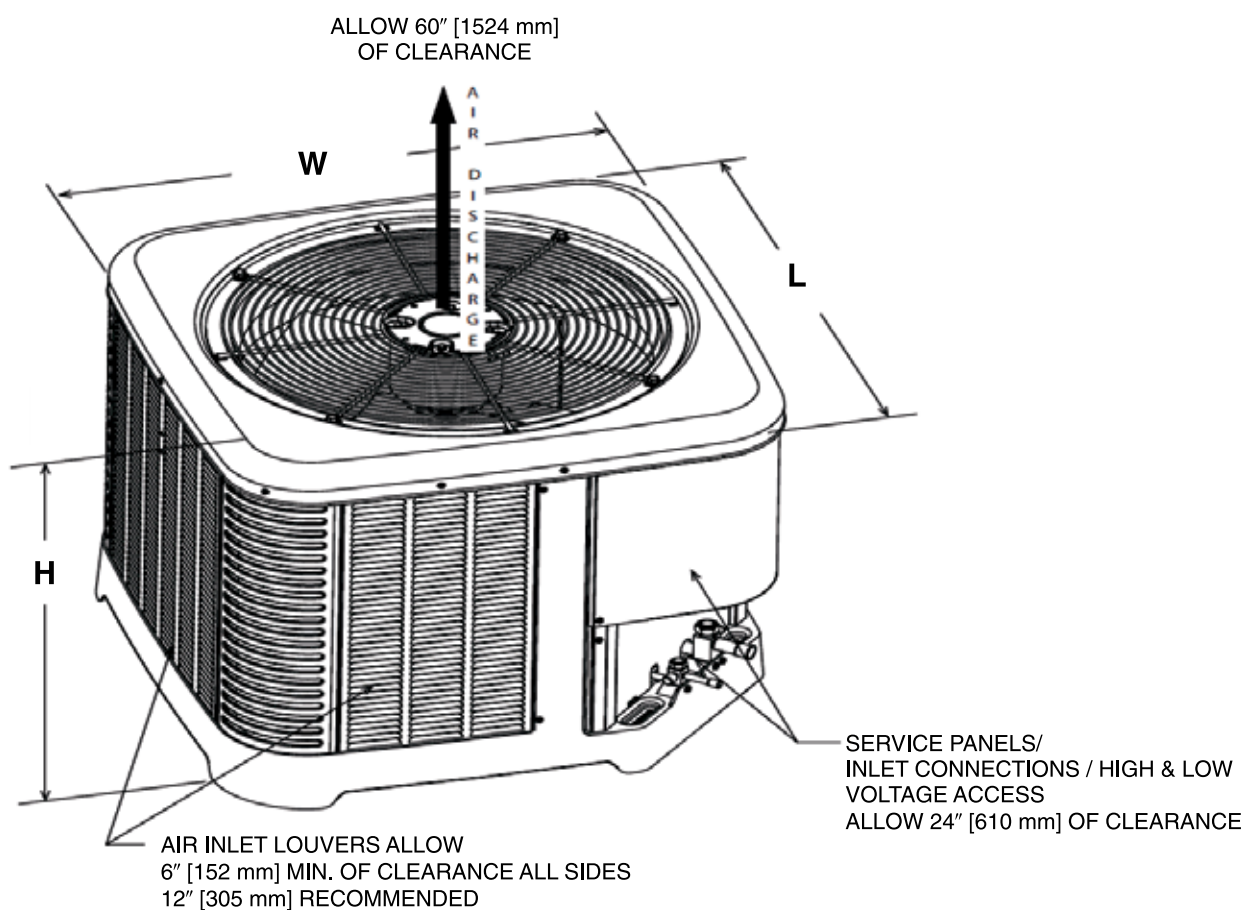

[] Designates Metric Conversions

ST-A1226-02-00

CLEARANCES

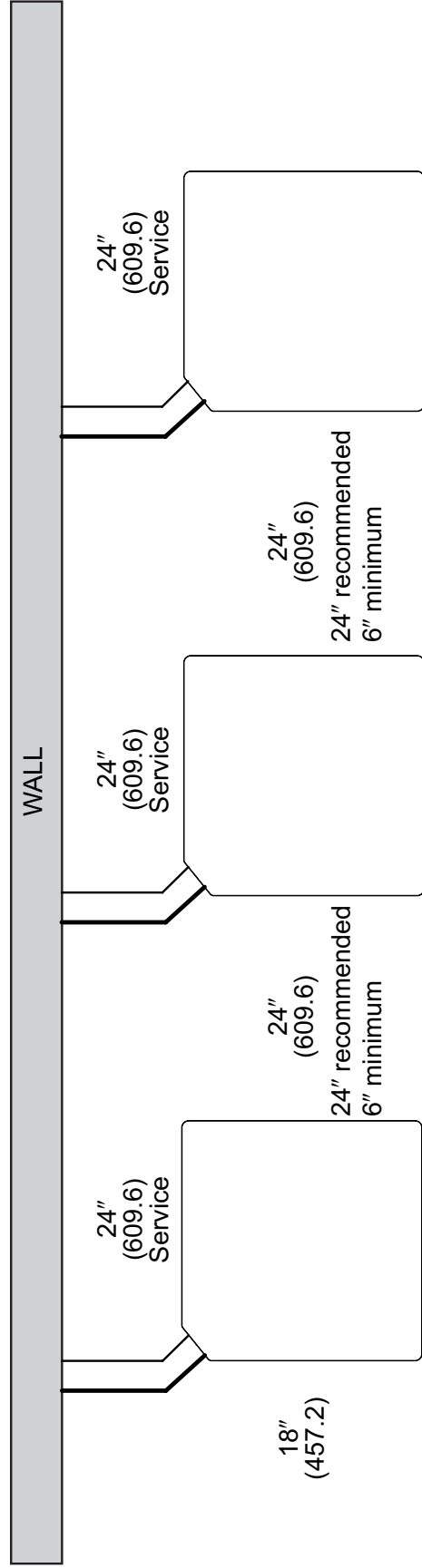
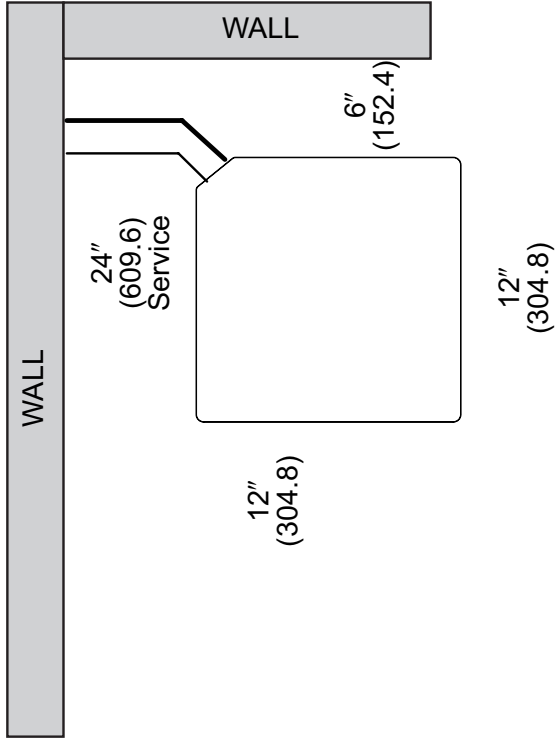
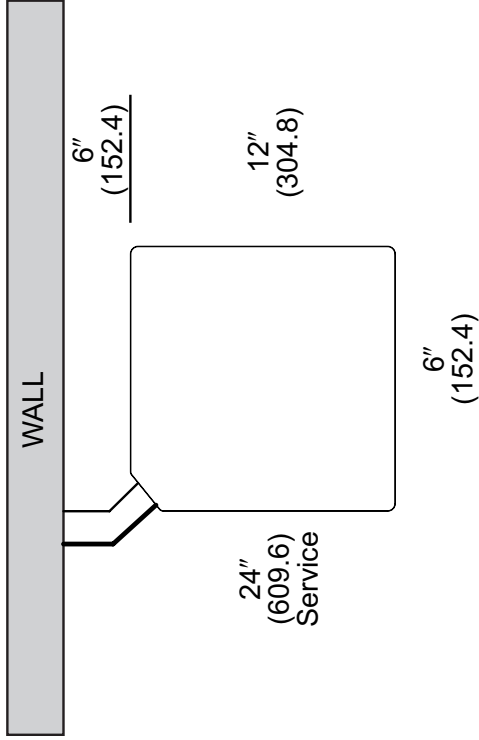

NOTE: NUMBERS IN () = mm

IMPORTANT: When installing multiple units in an alcove, roof well or partially enclosed area, ensure there is adequate ventilation to prevent re-circulation of discharge air.

Control Wiring

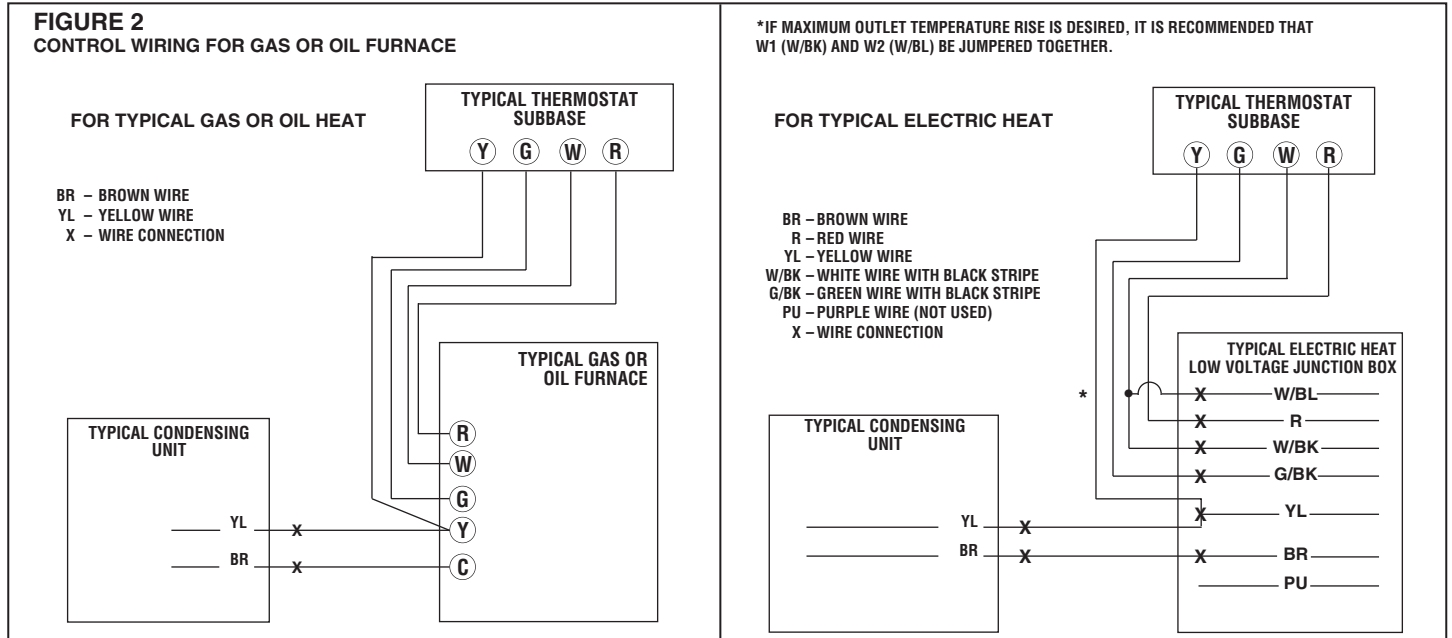

Application Guidelines

1. Intended for outdoor installation with free air inlet and outlet. Outdoor fan external static pressure available is less than 0.01 -in. wc.
2. Minimum outdoor operation air temperature for cooling mode without low-ambient operation accessory is 55°F (12.8°C).
3. Maximum outdoor operating air temperature is 125°F (51.7°C).
4. For reliable operation, unit should be level in all horizontal planes.
5. Use only copper wire for electric connections at unit. Aluminum and clad aluminum are not acceptable for the type of connector provided.
6. Do not apply capillary tube indoor coils to these units.
7. Factory-supplied filter drier must be installed.

Refrigerant Line Size Information

14.3 SEER2 SINGLE-STAGE AIR-CONDITIONERS																
UNIT SIZE	ALLOWABLE LIQUID LINE SIZE	ALLOWABLE SUCTION LINE SIZE	APPLY LONG LINE GUIDELINES IF LINEAR LINE LENGTH EXCEEDS THOSE SHOWN BELOW (FEET) (-JA14AZ)	EQUIVALENT LENGTH (FEET)												
				< 25	26-50	51-75	76-100	101-125	126-150	151-175	176-200	201-225	226-250			
				MAXIMUM VERTICAL RISE (OUTDOOR UNIT BELOW INDOOR UNIT) * / CAPACITY MULTIPLIER												
1.5 Ton **SEE NOTE 3	1/4"	5/8"	N/A	25 / 1.00	50 / 0.99	62 / 0.98	43 / 0.98	24 / 0.97	5 / 0.97	NR	NR	NR	NR	NR	NR	NR
	5/16"	5/8"	223	25 / 1.00	50 / 0.99	75 / 0.98	98 / 0.98	93 / 0.97	88 / 0.97	83 / 0.96	78 / 0.96	73 / 0.95	68 / 0.94			
	3/8"	5/8"	148	25 / 1.00	50 / 0.99	75 / 0.98	100 / 0.98	100 / 0.97	100 / 0.97	100 / 0.96	100 / 0.96	100 / 0.95	100 / 0.94			
	1/4"	3/4"***	N/A	25 / 1.00	50 / 1.00	62 / 0.99	43 / 0.99	24 / 0.99	5 / 0.99	NR	NR	NR	NR			
	5/16"	3/4"***	223	25 / 1.00	50 / 1.00	75 / 0.99	98 / 0.99	93 / 0.99	88 / 0.99	83 / 0.99	78 / 0.98	73 / 0.98	68 / 0.98			
	3/8"	3/4"***	148	25 / 1.00	50 / 1.00	75 / 1.00	100 / 0.99	100 / 0.99	100 / 0.99	100 / 0.99	100 / 0.98	100 / 0.98	100 / 0.98			
	1/4"	5/8"	N/A	25 / 0.99	50 / 0.98	21 / 0.97	NR	NR	NR	NR	NR	NR	NR	NR	NR	
2 Ton	5/16"	5/8"	213	25 / 0.99	50 / 0.98	75 / 0.97	87 / 0.96	77 / 0.95	69 / 0.94	61 / 0.93	53 / 0.92	45 / 0.91	37 / 0.90			
	3/8"	5/8"	142	25 / 0.99	50 / 0.98	75 / 0.97	100 / 0.96	100 / 0.95	100 / 0.94	98 / 0.93	95 / 0.92	92 / 0.91	89 / 0.90			
	1/4"	3/4"	N/A	25 / 1.00	50 / 1.00	21 / 0.99	NR	NR	NR	NR	NR	NR	NR			
	5/16"	3/4"	213	25 / 1.00	50 / 1.00	75 / 0.99	87 / 0.99	77 / 0.98	69 / 0.98	61 / 0.98	53 / 0.97	45 / 0.97	37 / 0.96			
	3/8"	3/4"	142	25 / 1.00	50 / 1.00	75 / 0.99	100 / 0.99	100 / 0.98	100 / 0.98	98 / 0.98	95 / 0.97	93 / 0.97	90 / 0.96			
	5/16"	5/8"	N/A	25 / 0.99	50 / 0.98	75 / 0.96	70 / 0.94	59 / 0.93	48 / 0.91	36 / 0.90	NR	NR	NR			
	3/8"	5/8"	117	25 / 0.99	50 / 0.98	75 / 0.96	100 / 0.94	98 / 0.93	94 / 0.91	90 / 0.90	NR	NR	NR			
2.5 Ton	5/16"	3/4"	175	25 / 1.00	50 / 0.99	75 / 0.99	70 / 0.98	59 / 0.98	48 / 0.97	36 / 0.96	25 / 0.96	13 / 0.95	NR			
	3/8"	3/4"	117	25 / 1.00	50 / 0.99	75 / 0.99	100 / 0.98	98 / 0.98	94 / 0.97	90 / 0.96	86 / 0.96	82 / 0.95	78 / 0.95			
	5/16"	5/8"	N/A	25 / 0.99	50 / 0.97	66 / 0.94	49 / 0.92	32 / 0.90	NR	NR	NR	NR	NR			
	3/8"	5/8"	85	25 / 0.99	50 / 0.97	75 / 0.94	95 / 0.92	89 / 0.90	NR	NR	NR	NR	NR			
	5/16"	3/4"	128	25 / 1.00	50 / 0.99	66 / 0.98	49 / 0.98	32 / 0.97	15 / 0.96	NR	NR	NR	NR			
	3/8"	3/4"	85	25 / 1.00	50 / 0.99	75 / 0.98	95 / 0.98	89 / 0.97	84 / 0.96	78 / 0.95	72 / 0.94	67 / 0.93	61 / 0.93			
	1/2"	3/4"	43	25 / 1.00	50 / 0.99	75 / 0.98	100 / 0.98	100 / 0.97	100 / 0.96	100 / 0.95	100 / 0.94	100 / 0.93	100 / 0.93			
3 Ton	5/16"	7/8"	128	25 / 1.00	50 / 1.00	66 / 1.00	49 / 0.99	32 / 0.99	15 / 0.99	NR	NR	NR	NR			
	3/8"	7/8"	85	25 / 1.00	50 / 1.00	75 / 1.00	95 / 0.99	89 / 0.99	84 / 0.99	78 / 0.98	72 / 0.98	67 / 0.98	61 / 0.97			
	1/2"	7/8"	43	25 / 1.00	50 / 1.00	75 / 1.00	100 / 0.99	100 / 0.99	100 / 0.99	100 / 0.98	100 / 0.98	100 / 0.98	100 / 0.97			
	3/8"	3/4"	102	25 / 0.99	50 / 0.98	75 / 0.97	88 / 0.96	80 / 0.95	72 / 0.94	65 / 0.92	57 / 0.91	49 / 0.90	NR			
	1/2"	3/4"	51	25 / 0.99	50 / 0.98	75 / 0.97	100 / 0.96	100 / 0.95	100 / 0.94	100 / 0.92	100 / 0.91	100 / 0.90	NR			
	3/8"	7/8"	102	25 / 1.00	50 / 1.00	75 / 0.99	88 / 0.99	80 / 0.99	72 / 0.98	65 / 0.97	57 / 0.97	49 / 0.96	42 / 0.96			
	1/2"	7/8"	51	25 / 1.00	50 / 1.00	75 / 0.99	100 / 0.99	100 / 0.99	100 / 0.98	100 / 0.97	100 / 0.97	100 / 0.96	100 / 0.96			

- NOTES:**
- 1) Do not exceed 200 ft linear line length.
 - 2) *Do not exceed 100 ft vertical separation if outdoor unit is above indoor unit.
 - 3) **3/4" suction line should only be used for 1.5 ton systems if outdoor unit is below or at same level as indoor to assure proper oil return.
 - 4) Always use the smallest liquid line allowable to minimize refrigerant charge.
 - 5) Applications shaded in light gray indicate capacity multipliers between 0.90 and 0.96 which are not recommended, but are allowed.
 - 6) Applications shaded in dark gray are not recommended due to excessive liquid or suction pressure drop.

Refrigerant Line Size Information (Con't.)

14.3 SEER2 SINGLE-STAGE AIR-CONDITIONERS													
UNIT SIZE	ALLOWABLE LIQUID LINE SIZE	ALLOWABLE SUCTION LINE SIZE	APPLY LONG LINE GUIDELINES IF LINEAR LINE LENGTH EXCEEDS THOSE SHOWN BELOW (FEET)	EQUIVALENT LENGTH (FEET)									
				< 25	26-50	51-75	76-100	101-125	126-150	151-175	176-200	201-225	226-250
				MAXIMUM VERTICAL RISE (OUTDOOR UNIT BELOW INDOOR UNIT) * / CAPACITY MULTIPLIER									
4 Ton	3/8"	3/4"	110	25 / 0.99	50 / 0.98	75 / 0.96	77 / 0.95	67 / 0.93	57 / 0.92	46 / 0.91	NR	NR	NR
	1/2"	3/4"	55	25 / 0.99	50 / 0.98	75 / 0.96	100 / 0.95	100 / 0.93	100 / 0.92	100 / 0.91	NR	NR	NR
	3/8"	7/8"	110	25 / 1.00	50 / 0.99	75 / 0.99	77 / 0.98	67 / 0.97	57 / 0.97	46 / 0.96	36 / 0.96	26 / 0.95	15 / 0.95
	1/2"	7/8"	55	25 / 1.00	50 / 0.99	75 / 0.99	100 / 0.98	100 / 0.97	100 / 0.97	100 / 0.96	100 / 0.96	99 / 0.95	97 / 0.95
	3/8"	3/4"	0	25 / 0.99	50 / 0.97	75 / 0.94	61 / 0.92	46 / 0.90	NR	NR	NR	NR	NR
	1/2"	3/4"	0	25 / 0.99	50 / 0.97	75 / 0.94	100 / 0.92	100 / 0.90	NR	NR	NR	NR	NR
5 Ton	3/8"	7/8"	0	25 / 1.00	50 / 0.99	75 / 0.98	61 / 0.97	46 / 0.96	32 / 0.95	18 / 0.94	NR	NR	NR
	1/2"	7/8"	0	25 / 1.00	50 / 0.99	75 / 0.98	100 / 0.97	100 / 0.96	100 / 0.95	97 / 0.94	95 / 0.94	92 / 0.93	89 / 0.92
	3/8"	1-1/8"	0	25 / 1.01	50 / 1.01	75 / 1.00	61 / 1.00	46 / 0.99	32 / 0.99	18 / 0.99	NR	NR	NR
	1/2"	1-1/8"	0	25 / 1.01	50 / 1.01	75 / 1.00	100 / 1.00	100 / 0.99	100 / 0.99	97 / 0.99	95 / 0.99	92 / 0.99	89 / 0.98

NOTES:

- 1) Do not exceed 200 ft linear line length.
- 2) *Do not exceed 100 ft vertical separation if outdoor unit is above indoor unit.
- 3) **3/4" suction line should only be used for 1.5 ton systems if outdoor unit is below or at same level as indoor to assure proper oil return.
- 4) Always use the smallest liquid line allowable to minimize refrigerant charge.
- 5) Applications shaded in light gray indicate capacity multipliers between 0.90 and 0.96 which are not recommended, but are allowed.
- 6) Applications shaded in dark gray are not recommended due to excessive liquid or suction pressure drop.

Refrigerant Line Size Information

14.3 SEER2 SINGLE-STAGE AIR-CONDITIONERS																		
UNIT SIZE	ALLOWABLE LIQUID LINE SIZE (IN.)	ALLOWABLE SUCTION LINE SIZE (IN.)	APPLY LONG LINE GUIDELINES IF LINEAR LINE LENGTH EXCEEDS THOSE SHOWN BELOW (METERS)	EQUIVALENT LENGTH (METERS)														
				< 8	8-15	16-23	24-30	31-38	39-46	47-53	54-61	62-69	70-76					
				MAXIMUM VERTICAL RISE (OUTDOOR UNIT BELOW INDOOR UNIT) * / CAPACITY MULTIPLIER														
5.3 KW [1.5 Ton] **SEE NOTE 3	6.35 [1/4]	15.88 [5/8]	N/A	8 / 1.00	15 / 0.99	19 / 0.98	13 / 0.98	7 / 0.97	2 / 0.97	NR	NR	NR	NR	NR	NR	NR		
	7.94 [5/16]	15.88 [5/8]	68	8 / 1.00	15 / 0.99	23 / 0.98	30 / 0.98	28 / 0.97	27 / 0.97	25 / 0.96	24 / 0.96	22 / 0.95	21 / 0.94	21 / 0.94	21 / 0.94	21 / 0.94		
	9.53 [3/8]	15.88 [5/8]	45	8 / 1.00	15 / 0.99	23 / 0.98	30 / 0.98	30 / 0.97	30 / 0.97	30 / 0.96	30 / 0.96	30 / 0.95	30 / 0.95	30 / 0.94	30 / 0.94	30 / 0.94		
	6.35 [1/4]	19.05 [3/4]**	N/A	8 / 1.00	15 / 1.00	19 / 0.99	13 / 0.99	7 / 0.99	2 / 0.99	NR	NR	NR	NR	NR	NR	NR	NR	
	7.94 [5/16]	19.05 [3/4]**	68	8 / 1.00	15 / 1.00	23 / 0.99	30 / 0.99	28 / 0.99	27 / 0.99	25 / 0.99	24 / 0.98	22 / 0.98	21 / 0.98	21 / 0.98	21 / 0.98	21 / 0.98	21 / 0.98	
	9.53 [3/8]	19.05 [3/4]**	45	8 / 1.00	15 / 1.00	23 / 0.99	30 / 0.99	30 / 0.99	30 / 0.99	30 / 0.99	30 / 0.98	30 / 0.98	30 / 0.98	30 / 0.98	30 / 0.98	30 / 0.98	30 / 0.98	30 / 0.98
7.0 KW [2 Ton]	6.35 [1/4]	15.88 [5/8]	N/A	8 / 0.99	15 / 0.98	6 / 0.97	NR	NR	NR	NR	NR	NR	NR	NR	NR	NR	NR	
	7.94 [5/16]	15.88 [5/8]	59	8 / 0.99	15 / 0.98	23 / 0.97	27 / 0.96	23 / 0.95	21 / 0.94	19 / 0.93	16 / 0.92	14 / 0.91	11 / 0.90	11 / 0.90	11 / 0.90	11 / 0.90	11 / 0.90	
	9.53 [3/8]	15.88 [5/8]	39	8 / 0.99	15 / 0.98	23 / 0.97	30 / 0.96	30 / 0.95	30 / 0.94	30 / 0.93	29 / 0.92	28 / 0.91	27 / 0.90	27 / 0.90	27 / 0.90	27 / 0.90	27 / 0.90	
	6.35 [1/4]	19.05 [3/4]	N/A	8 / 1.00	15 / 1.00	6 / 0.99	NR	NR	NR	NR	NR	NR	NR	NR	NR	NR	NR	NR
	7.94 [5/16]	19.05 [3/4]	59	8 / 1.00	15 / 1.00	23 / 0.99	27 / 0.99	23 / 0.98	21 / 0.98	19 / 0.98	16 / 0.97	14 / 0.97	11 / 0.96	11 / 0.96	11 / 0.96	11 / 0.96	11 / 0.96	
	9.53 [3/8]	19.05 [3/4]	39	8 / 1.00	15 / 1.00	23 / 0.99	30 / 0.99	30 / 0.99	30 / 0.98	30 / 0.98	29 / 0.97	28 / 0.97	27 / 0.96	27 / 0.96	27 / 0.96	27 / 0.96	27 / 0.96	27 / 0.96
8.8 KW [2.5 Ton]	7.94 [5/16]	15.88 [5/8]	N/A	8 / 0.99	15 / 0.98	23 / 0.96	21 / 0.94	18 / 0.93	15 / 0.91	11 / 0.90	NR	NR	NR	NR	NR	NR	NR	
	9.53 [3/8]	15.88 [5/8]	36	8 / 0.99	15 / 0.98	23 / 0.96	30 / 0.94	30 / 0.93	29 / 0.91	27 / 0.90	NR	NR	NR	NR	NR	NR	NR	
	7.94 [5/16]	19.05 [3/4]	53	8 / 1.00	15 / 0.99	23 / 0.99	21 / 0.98	18 / 0.98	15 / 0.97	11 / 0.96	8 / 0.96	4 / 0.95	NR	NR	NR	NR	NR	
	9.53 [3/8]	19.05 [3/4]	36	8 / 1.00	15 / 0.99	23 / 0.99	30 / 0.98	30 / 0.98	29 / 0.97	27 / 0.96	26 / 0.96	25 / 0.95	24 / 0.95	24 / 0.95	24 / 0.95	24 / 0.95	24 / 0.95	
	7.94 [5/16]	15.88 [5/8]	N/A	8 / 0.99	15 / 0.97	20 / 0.94	15 / 0.92	10 / 0.90	NR	NR	NR	NR	NR	NR	NR	NR	NR	NR
	9.53 [3/8]	15.88 [5/8]	26	8 / 0.99	15 / 0.97	23 / 0.94	29 / 0.92	27 / 0.90	NR	NR	NR	NR	NR	NR	NR	NR	NR	NR
10.6 KW [3 Ton]	7.94 [5/16]	19.05 [3/4]	39	8 / 1.00	15 / 0.99	20 / 0.98	15 / 0.98	10 / 0.97	5 / 0.96	NR	NR	NR	NR	NR	NR	NR	NR	
	9.53 [3/8]	19.05 [3/4]	26	8 / 1.00	15 / 0.99	23 / 0.98	29 / 0.98	27 / 0.97	26 / 0.96	24 / 0.95	22 / 0.94	20 / 0.93	19 / 0.93	19 / 0.93	19 / 0.93	19 / 0.93	19 / 0.93	
	12.70 [1/2]	19.05 [3/4]	13	8 / 1.00	15 / 0.99	23 / 0.98	30 / 0.98	30 / 0.97	30 / 0.96	30 / 0.95	30 / 0.94	30 / 0.93	30 / 0.93	30 / 0.93	30 / 0.93	30 / 0.93	30 / 0.93	
	7.94 [5/16]	22.23 [7/8]	39	8 / 1.00	15 / 1.00	20 / 1.00	15 / 0.99	10 / 0.99	5 / 0.99	NR	NR	NR	NR	NR	NR	NR	NR	
	9.53 [3/8]	22.23 [7/8]	26	8 / 1.00	15 / 1.00	23 / 1.00	29 / 0.99	27 / 0.99	26 / 0.99	24 / 0.98	22 / 0.98	20 / 0.98	19 / 0.97	19 / 0.97	19 / 0.97	19 / 0.97	19 / 0.97	
	12.70 [1/2]	22.23 [7/8]	13	8 / 1.00	15 / 1.00	23 / 1.00	30 / 0.99	30 / 0.99	30 / 0.99	30 / 0.99	30 / 0.98	30 / 0.98	30 / 0.98	30 / 0.98	30 / 0.98	30 / 0.98	30 / 0.98	
12.3 KW [3.5 Ton]	9.53 [3/8]	19.05 [3/4]	31	8 / 0.99	15 / 0.98	23 / 0.97	27 / 0.96	24 / 0.95	22 / 0.94	20 / 0.92	17 / 0.91	15 / 0.90	NR	NR	NR	NR	NR	
	12.70 [1/2]	19.05 [3/4]	15	8 / 0.99	15 / 0.98	23 / 0.97	30 / 0.96	30 / 0.95	30 / 0.94	30 / 0.92	30 / 0.91	30 / 0.90	30 / 0.90	30 / 0.90	30 / 0.90	30 / 0.90	30 / 0.90	
	9.53 [3/8]	22.23 [7/8]	31	8 / 1.00	15 / 1.00	23 / 0.99	27 / 0.99	24 / 0.99	22 / 0.98	20 / 0.97	17 / 0.97	15 / 0.96	13 / 0.96	13 / 0.96	13 / 0.96	13 / 0.96	13 / 0.96	
	12.70 [1/2]	22.23 [7/8]	15	8 / 1.00	15 / 1.00	23 / 0.99	30 / 0.99	30 / 0.99	30 / 0.99	30 / 0.97	30 / 0.97	30 / 0.96	30 / 0.96	30 / 0.96	30 / 0.96	30 / 0.96	30 / 0.96	

- NOTES:**
- 1) Do not exceed 61m linear line length.
 - 2) *Do not exceed 30m vertical separation if outdoor unit is above indoor unit.
 - 3) **19.05mm suction line should only be used for 1.5 ton systems if outdoor unit is below or at same level as indoor to assure proper oil return.
 - 4) Always use the smallest liquid line allowable to minimize refrigerant charge.
 - 5) Applications shaded in light gray indicate capacity multipliers between 0.90 and 0.96 which are not recommended, but are allowed.
 - 6) Applications shaded in dark gray are not recommended due to excessive liquid or suction pressure drop.

Refrigerant Line Size Information (Con't.)

14.3 SEER2 SINGLE-STAGE AIR-CONDITIONERS													
UNIT SIZE	ALLOWABLE LIQUID LINE SIZE (MM [IN.])	ALLOWABLE SUCTION LINE SIZE (MM [IN.])	APPLY LONG LINE GUIDELINES IF LINEAR LINE LENGTH EXCEEDS THOSE SHOWN BELOW (METERS)	EQUIVALENT LENGTH (METERS)									
				< 25	26-50	51-75	76-100	101-125	126-150	151-175	176-200	201-225	226-250
				MAXIMUM VERTICAL RISE (OUTDOOR UNIT BELOW INDOOR UNIT) * / CAPACITY MULTIPLIER									
14.1 kW [4 Ton]	9.53 [3/8]	19.05 [3/4]	34	8 / 0.99	15 / 0.98	23 / 0.96	24 / 0.95	20 / 0.93	17 / 0.92	14 / 0.91	NR	NR	NR
	12.7 [1/2]	19.05 [3/4]	17	8 / 0.99	15 / 0.98	23 / 0.96	30 / 0.95	30 / 0.93	30 / 0.92	30 / 0.91	NR	NR	NR
	9.53 [3/8]	22.23 [7/8]	34	8 / 1.00	15 / 0.99	23 / 0.99	24 / 0.98	20 / 0.97	17 / 0.97	14 / 0.96	11 / 0.96	8 / 0.95	5 / 0.95
	12.7 [1/2]	22.23 [7/8]	17	8 / 1.00	15 / 0.99	23 / 0.99	30 / 0.98	30 / 0.97	30 / 0.97	30 / 0.96	30 / 0.96	30 / 0.95	30 / 0.95
17.6 kW [5 Ton]	9.53 [3/8]	19.05 [3/4]	0	8 / 0.99	15 / 0.97	23 / 0.94	19 / 0.92	14 / 0.90	NR	NR	NR	NR	NR
	12.7 [1/2]	19.05 [3/4]	0	8 / 0.99	15 / 0.97	23 / 0.94	30 / 0.92	30 / 0.90	NR	NR	NR	NR	NR
	9.53 [3/8]	22.23 [7/8]	0	8 / 1.00	15 / 0.99	23 / 0.98	19 / 0.97	14 / 0.96	10 / 0.95	5 / 0.94	NR	NR	NR
	12.7 [1/2]	22.23 [7/8]	0	8 / 1.00	15 / 0.99	23 / 0.98	30 / 0.97	30 / 0.96	30 / 0.95	30 / 0.94	29 / 0.94	28 / 0.93	27 / 0.92
	9.53 [3/8]	28.58 [1-1/8]	0	8 / 1.01	15 / 1.01	23 / 1.00	19 / 1.00	14 / 0.99	10 / 0.99	5 / 0.99	NR	NR	NR
	12.7 [1/2]	28.58 [1-1/8]	0	8 / 1.01	15 / 1.01	23 / 1.00	30 / 1.00	30 / 0.99	30 / 0.99	30 / 0.99	29 / 0.99	28 / 0.99	27 / 0.98

NOTES:

- 1) Do not exceed 61m linear line length.
- 2) *Do not exceed 30m vertical separation if outdoor unit is above indoor unit.
- 3) ***19.05mm suction line should only be used for 1.5 ton systems if outdoor unit is below or at same level as indoor to assure proper oil return.
- 4) Always use the smallest liquid line allowable to minimize refrigerant charge.
- 5) Applications shaded in light gray indicate capacity multipliers between 0.90 and 0.96 which are not recommended, but are allowed.
- 6) Applications shaded in dark gray are not recommended due to excessive liquid or suction pressure drop.

Performance Data @ AHRI Standard Conditions – Cooling

DESIGNATED TESTED COMBINATION (DTC)							
OUTDOOR UNIT	INDOOR COIL	TOTAL CAPACITY BTU/H [KW]	NET SENSIBLE BTU/H [KW]	NET LATENT BTU/H [KW]	SEER2	EER2	INDOOR CFM [L/s]
RA14AZ18AJ1	RCFZ2417STAN	17,100 [5.0]	13,100 [3.8]	4,000 [1.2]	14.3	11.7	600 [283.2]
RA14AZ24AJ1	RCFZ2417STAN	22,800 [6.7]	17,500 [5.1]	5,300 [1.6]	14.3	11.7	725 [342.2]
RA14AZ30AJ1	RCFZ3617STAN	28,600 [8.4]	21,800 [6.4]	6,800 [2.0]	14.3	11.7	900 [424.8]
RA14AZ36AJ1	RCFZ3617STAN	34,200 [10.0]	26,200 [7.7]	8,000 [2.3]	14.3	11.7	1,025 [483.7]
RA14AZ42AJ1	RCFZ4821STAN	38,500 [11.3]	29,500 [8.6]	9,000 [2.6]	14.3	11.7	1,300 [613.5]
RA14AZ48AJ1	RCFZ4821STAN	45,000 [13.2]	34,500 [10.1]	10,500 [3.1]	13.8	11.2	1,425 [672.5]
RA14AZ60AJ1	RCFZ6024STAN	56,000 [16.4]	42,900 [12.6]	13,100 [3.8]	13.8	11.2	1,600 [755.1]

NOTE: This data includes DTC (Designated Test Combination) ratings and is for reference purposes only. A full listing of official ratings and system match-ups, along with downloadable certificates, can be accessed from the AHRI website: www.ahrirectory.org.

[] Designates Metric Conversions



The new degree of comfort.®

Endeavor™ Line *Classic Plus*® Series iM Air Conditioners



This product meets a stringent set of our internally defined sustainability standards

RA15AZ

Cooling Efficiencies up to: 15.2 SEER2/9.8 EER2

Nominal Sizes: 2 to 5 Ton [7.0 to 17.6 kW]

Cooling Capacities: 22.8 to 56.0 kBTU [6.68 to 16.4 kW]



The Bluetooth® word mark and logos are registered trademarks owned by Bluetooth SIG, Inc. and any use of such marks by Rheem® is under license. Other trademarks and trade names are those of their respective owners.

Table of Contents

Features & Benefits	3
Model Number Identification	4
General Data/Electrical Data	5
Accessories	6
Unit Dimensions	7
Clearances	8
Control Wiring	9
Application Guidelines.....	9
Refrigerant Line Size Information	10-11
Performance Data	12
Smart Home Systems	13
Limited Warranty	16

Features and Benefits

- **EcoNet® Enabled:** Automatic system configuration and optimization
- **PlusOne® Diagnostics & Bluetooth®¹ Connectivity:** With the Rheem Contractor & EcoNet® Apps, built-in technology makes advanced set-up, monitoring, troubleshooting and repairing the product easier than ever before
- **PlusOne® Variable Speed Twin Rotary Compressor & Inverter Drive:**
 - Features Inverter operation from 40 to 70% capacity or 100% capacity via line voltage with the EcoNet® Smart Thermostat
 - 3-speed operation when installed with a 24V two-stage thermostat
 - Provides precise temperature control, advanced humidity control and greater efficiency
- **Swept Wing Fan Technology:** Features quieter operation and improved unit acoustics
- **7mm Condenser Copper Coil:** Requires less refrigerant allowing for a smaller and lighter footprint while enhancing reliability
- **PlusOne® Expanded Value Space:** 3 in. – 4 in. – 5 in. service valve space—provides a minimum working area of 27-square inches for easier access
- **PlusOne® Triple Service Access:** 15 in. wide, industry leading corner service access, two fastener, removeable corner and individual louver panels—makes repairs easier and faster

¹The Bluetooth® word mark and logos are registered trademarks owned by Bluetooth SIG, Inc. and any use of such marks by Rheem® is under license. Other trademarks and trade names are those of their respective owners

Air Conditioners

<u>R</u>	<u>A</u>	<u>15</u>	<u>A</u>	<u>Z</u>	<u>24</u>	<u>A</u>	<u>J</u>	<u>3</u>	<u>C</u>	<u>A</u>
Brand	Product Category	SEER2	Region	Refrigerant	Capacity BTU/HR	Major Series	Voltage	Type	Controls	Minor Series
R - Rheem	A - Air Conditioners	15 - 15.2 SEER2	A - All	Z - R-410A	24 - 24,000 [7.03 kW] 36 - 36,000 [10.55 kW] 48 - 48,000 [14.07 kW] 60 - 60,000 [17.58 kW]	A - 1st Design	J - 1ph, 208-230/60	3 - 3+ Stage	C - Communicating	A - 1st Design

[] Designates Metric Conversions

Available Models	Description
RA15AZ24AJ3CA	Endeavor™ Line <i>Classic Plus</i> ® Series 2 ton EcoNet® Enabled 3+ Speed iM Air Conditioner – 208/230/1/60
RA15AZ36AJ3CA	Endeavor™ Line <i>Classic Plus</i> ® Series 3 ton EcoNet® Enabled 3+ Speed iM Air Conditioner – 208/230/1/60
RA15AZ48AJ3CA	Endeavor™ Line <i>Classic Plus</i> ® Series 4 ton EcoNet® Enabled 3+ Speed iM Air Conditioner – 208/230/1/60
RA15AZ60AJ3CA	Endeavor™ Line <i>Classic Plus</i> ® Series 5 ton EcoNet® Enabled 3+ Speed iM Air Conditioner – 208/230/1/60

Standard Equipment
R-410A Refrigerant
Variable Speed Twin Rotary Compressor
Field Installed Filter Drier
Front Seating Service Valves
Internal Pressure Relief Valve
Internal Thermal Overload
Long Line capability
Low Ambient capability with Kit
3-4-5 Expanded Valve Space
Composite Basepan
2 Screw Control Box Access
15" Access to Internal Components
Quick release louver panel design
No fasteners to remove along bottom
Optimized Venturi Airflow
Single row condenser coil
Powder coated paint
Rust resistant screws
QR code
External gauge ports
Service trays

General Data				
Model No.	RA15AZ24AJ3	RA15AZ36AJ3	RA15AZ48AJ3	RA15AZ60AJ3
Nominal Tonnage	2.0	3.0	4.0	5.0
Valve Connections				
Liquid Line O.D. – in.	3/8	3/8	3/8	3/8
Suction Line O.D. – in.	3/4	3/4	7/8	7/8
Refrigerant (R410A) furnished oz.¹	91	119	130	154
Compressor Type	Twin Rotary			
Outdoor Coil				
Net face area – Outer Coil	11.79	14.4	16.42	17.88
Net face area – Inner Coil	—	—	—	—
Tube diameter – in.	0.276	0.276	0.276	0.276
Number of rows	1	1	1	1
Fins per inch	24	24	24	24
Outdoor Fan				
Diameter – in.	20	24	24	26
Number of blades	3	3	3	3
Motor hp	1/5	1/5	1/3	1/2
CFM	2908	4138	4529	5274
RPM	1075	1000	1075	1075
watts	170	267	294	370
Shipping weight – lbs.	174	198	230	251
Operating weight – lbs.	167	191	223	244
Electrical Data				
Line Voltage Data (Volts-Phase-Hz)	208/230-1-60	208/230-1-60	208/230-1-60	208/230-1-60
Maximum overcurrent protection (amps)²	20	30	40	50
Minimum circuit ampacity³	12	20	25	32
Compressor				
Rated load amps	10	15	20	25
Locked rotor amps	65	70	96	119

¹Refrigerant charge sufficient for 15 ft. length of refrigerant lines. For longer line set requirements see the installation instructions for information about set length and additional refrigerant charge required.

²HACR type circuit breaker or fuse.

³Refer to National Electrical Code manual to determine wire, fuse and disconnect size requirements.

Accessories

Model No.		RA15AZ24AJ3	RA15AZ36AJ3	RA15AZ48AJ3	RA15AZ60AJ3
Compressor crankcase heater*		N/A	N/A	N/A	N/A
Low ambient control		47-102709-10	47-102709-10	47-102709-10	47-102709-10
Compressor sound cover		68-23427-27	68-23427-28	68-23427-29	68-23427-29
Low pressure control		47-103454-01	47-103454-01	47-103454-01	47-103454-01
High pressure control		47-103669-02	47-103669-02	47-103669-02	47-103669-02
Liquid Line Solenoid (24 VAC, 50/60 Hz)	Solenoid Valve	200RD2T3TVLC	200RD2T3TVLC	200RD2T3TVLC	200RD2T3TVLC
	Solenoid Coil	61-AMG24V	61-AMG24V	61-AMG24V	61-AMG24V
Liquid Line Solenoid (120/240 VAC, 50/60 Hz)	Solenoid Valve	200RD2T3TVLC	200RD2T3TVLC	200RD2T3TVLC	200RD2T3TVLC
	Solenoid Coil	61-AMG120/240V	61-AMG120/240V	61-AMG120/240V	61-AMG120/240V

*Crankcase Heater recommended with Low Ambient Kit.

Weighted Sound Power Level (dBA)

Unit Size - Voltage, Series	Standard Rating (dBA) Low Speed/ High Speed	TYPICAL OCTAVE BAND SPECTRUM (dBA without tone adjustment)							Sound Power Level [dB(A)] with Sound Blanket
		125	250	500	1000	2000	4000	8000	
RA15AZ24AJ3	63.3	35.9	47.9	55.3	53.2	50.4	47.1	43.8	Sound Blankets - Standard
	71.7	46.1	59.1	63.2	60.8	58.7	56.5	47.9	
RA15AZ36AJ3	61.4	38.5	48.0	53.8	49.2	45.9	47.0	47.4	
	72.9	47.5	59.5	64.9	60.7	62.6	57.0	49.6	
RA15AZ48AJ3	63.8	42.3	45.9	53.5	48.9	45.8	59.1	36.4	
	76.2	49.4	61.4	68.1	53.9	60.8	57.4	48.5	
RA15AZ60AJ3	65.7	39.7	49.0	58.2	54.5	52.2	53.8	41.3	
	76.7	49.3	64.6	68.1	65.1	62.6	58.6	53.0	

NOTE: Tested in accordance with AHRI Standard 270-08 (not listed in AHRI)

Unit Dimensions

Model No.	Operating						Shipping					
	H (Height)		L (Length)		W (Width)		H (Height)		L (Length)		W (Width)	
	Inches	mm	Inches	mm	Inches	mm	Inches	mm	Inches	mm	Inches	mm
RA15AZ24AJ3	27.00	686	29.75	756	29.75	756	28.50	724	32.38	822	32.38	822
RA15AZ36AJ3	27.00	686	33.75	857	33.75	857	28.50	724	36.38	924	36.38	924
RA15AZ48AJ3	31.00	787	33.75	857	33.75	857	32.50	826	36.38	924	36.38	924
RA15AZ60AJ3	31.00	787	35.75	908	35.75	908	32.50	826	38.38	975	38.38	975

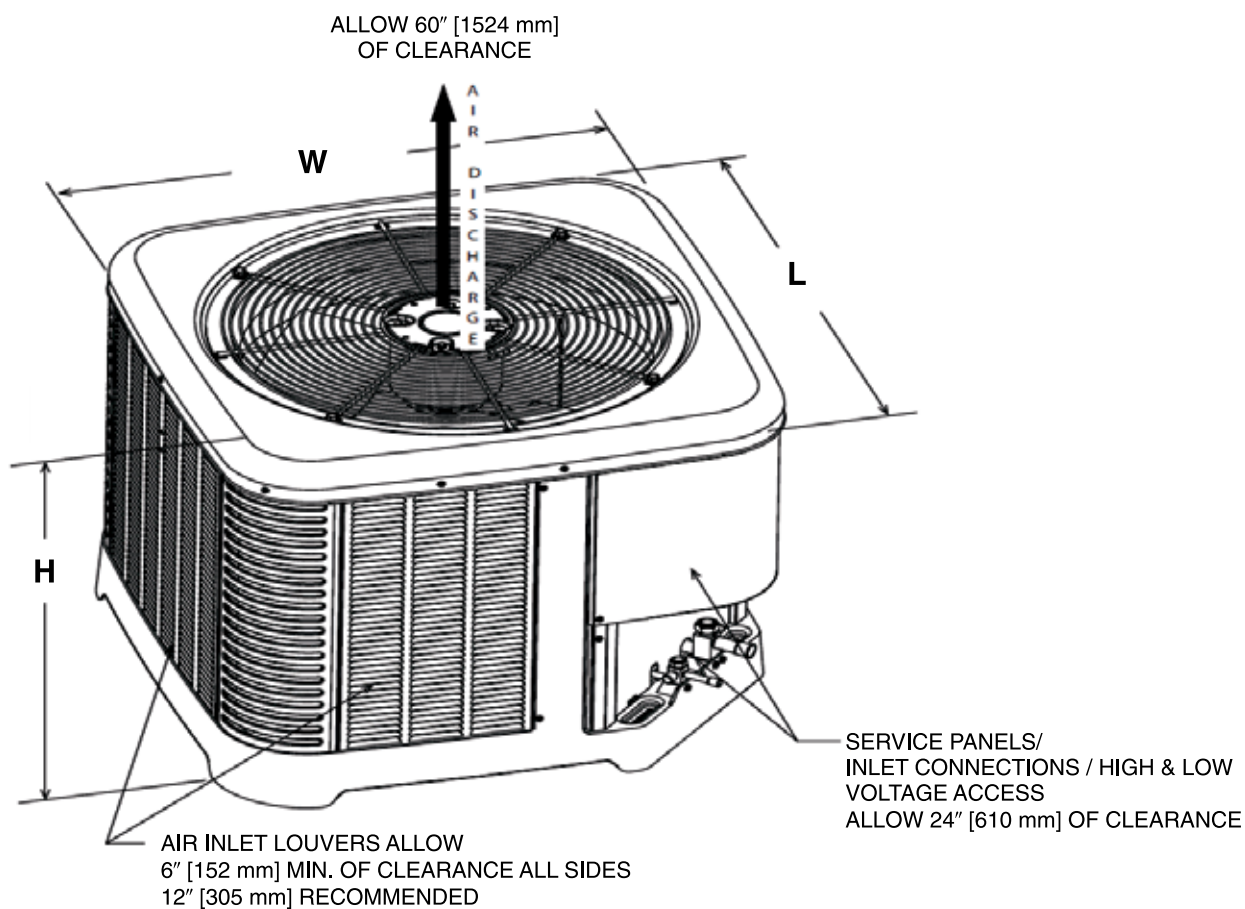

[] Designates Metric Conversions

ST-A1226-02-00

CLEARANCES

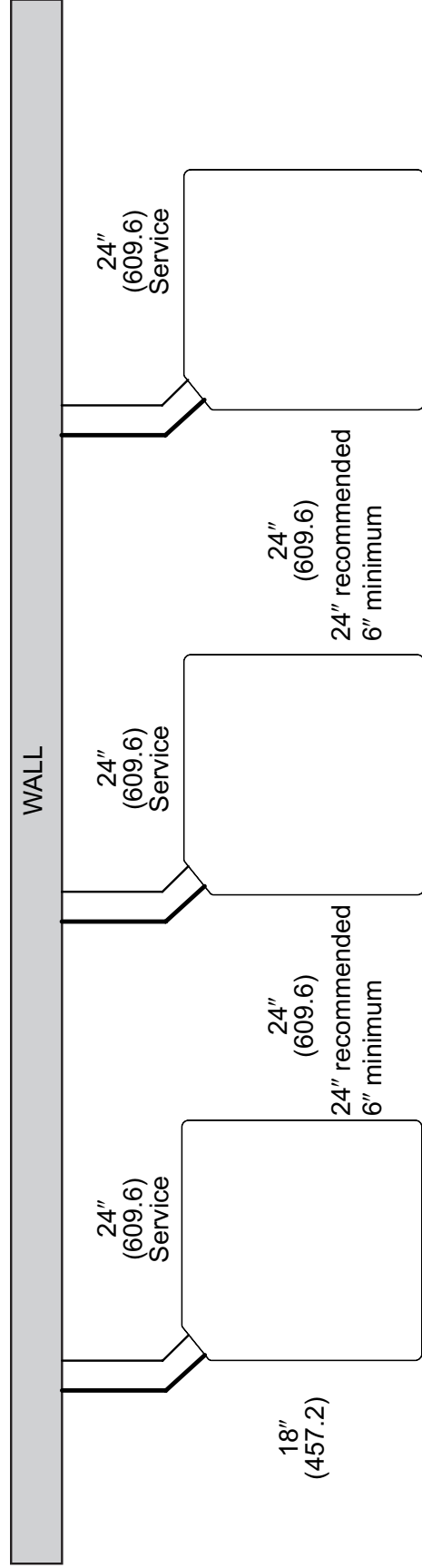
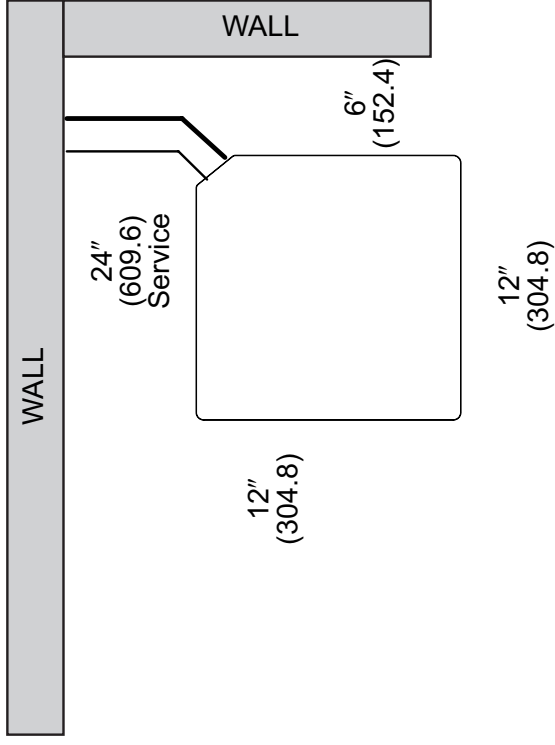
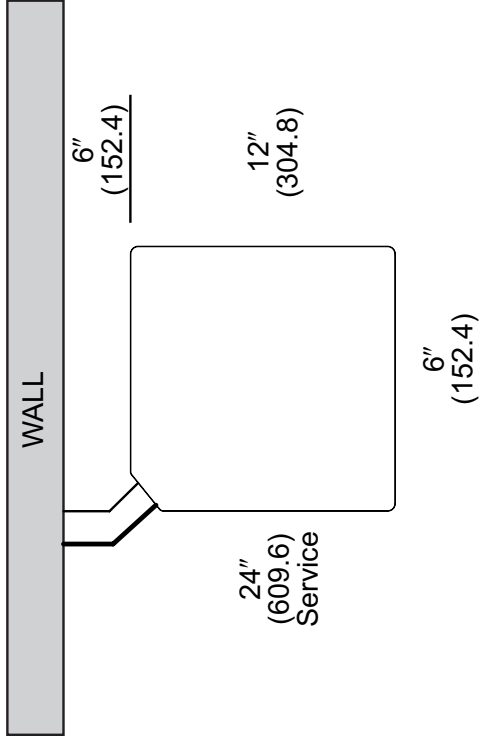

NOTE: NUMBERS IN () = mm

IMPORTANT: When installing multiple units in an alcove, roof well or partially enclosed area, ensure there is adequate ventilation to prevent re-circulation of discharge air.

Control Wiring

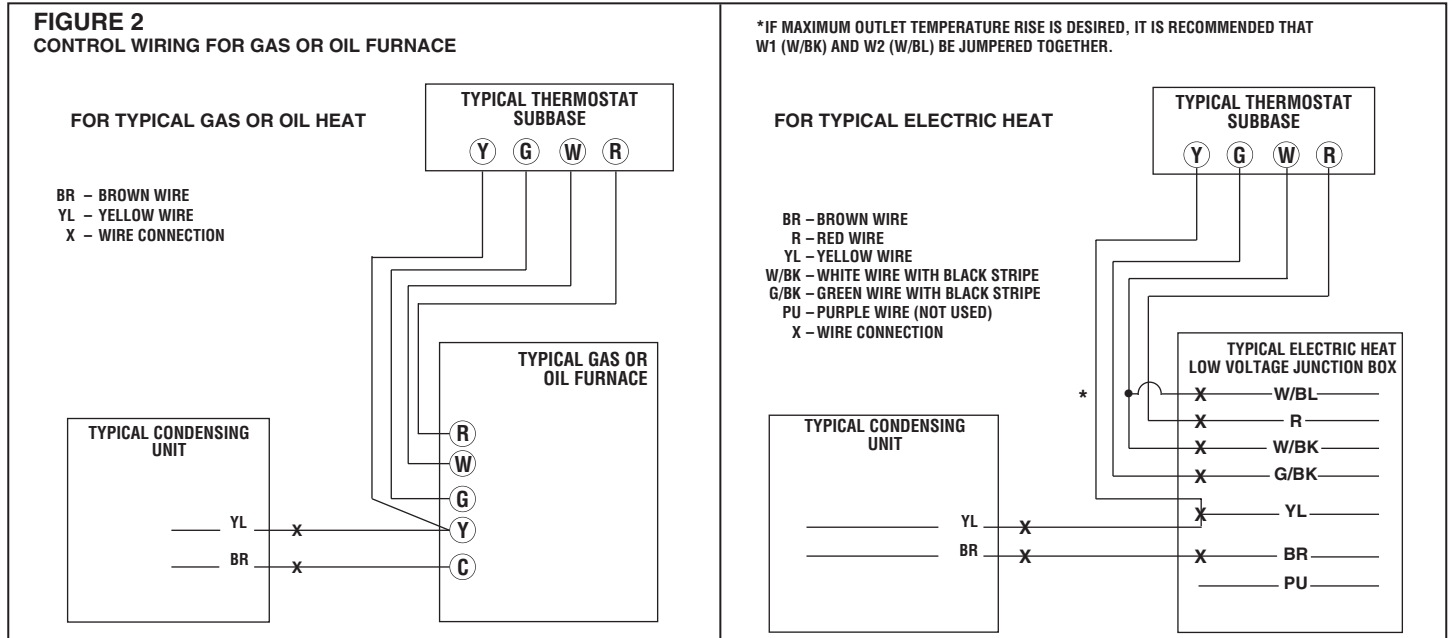

Application Guidelines

1. Intended for outdoor installation with free air inlet and outlet. Outdoor fan external static pressure available is less than 0.01 -in. wc.
2. Minimum outdoor operation air temperature for cooling mode without low-ambient operation accessory is 55°F (12.8°C).
3. Maximum outdoor operating air temperature is 125°F (51.7°C).
4. For reliable operation, unit should be level in all horizontal planes.
5. Use only copper wire for electric connections at unit. Aluminum and clad aluminum are not acceptable for the type of connector provided.
6. Do not apply capillary tube indoor coils to these units.
7. Factory-supplied filter drier must be installed.

Refrigerant Line Size Information

15/16 SEER2 Variable Speed Air Conditioners								
Unit Size	Allowable Liquid Line Size	Allowable Vapor Line Size	Outdoor Unit ABOVE or BELOW Indoor Unit Equivalent Length (Feet)					
			< 25	26-50	51-75	76-100	101-125	126-150
			Maximum Vertical Separation / Capacity Multiplier					
2.0 Ton **SEE NOTE 3	1/4"	5/8"	25/1.00	50/0.99	32/0.98	40/0.97	NR	NR
	5/16"	5/8"	25/1.00	50/0.99	50/0.98	50/0.97	50/0.96	50/0.95
	3/8"	5/8"	25/1.00	50/0.99	50/0.98	50/0.97	50/0.96	50/0.95
	1/4"	3/4"	25/1.00	50/1.00	32/0.99	40/0.99	NR	NR
	5/16"	3/4"	25/1.00	50/1.00	50/0.99	50/0.99	50/0.99	50/0.98
	3/8"	3/4"	25/1.00	50/1.00	50/0.99	50/0.99	50/0.99	50/0.98
3 Ton	5/16"	5/8"	25/0.99	50/0.97	50/0.95	50/0.93	37/0.91	NR
	3/8"	5/8"	25/0.99	50/0.97	50/0.95	50/0.93	50/0.91	NR
	5/16"	3/4"	25/1.00	50/0.99	50/0.99	50/0.98	37/0.97	22/0.96
	3/8"	3/4"	25/1.00	50/0.99	50/0.99	50/0.98	50/0.97	50/0.96
	1/2"	3/4"	25/1.00	50/0.99	50/0.99	50/0.98	50/0.97	50/0.96
4 Ton	3/8"	3/4"	25/0.99	50/0.98	50/0.97	50/0.96	50/0.94	50/0.93
	1/2"	3/4"	25/0.99	50/0.98	50/0.97	50/0.96	50/0.94	50/0.93
	3/8"	7/8"	25/1.00	50/0.99	50/0.99	50/0.98	50/0.98	50/0.97
	1/2"	7/8"	25/1.00	50/0.99	50/0.99	50/0.98	50/0.98	50/0.97
5 Ton	3/8"	3/4"	25/0.99	50/0.97	50/0.95	50/0.93	50/0.91	NR
	1/2"	3/4"	25/0.99	50/0.97	50/0.95	50/0.93	50/0.91	NR
	3/8"	7/8"	25/1.00	50/0.99	50/0.98	50/0.98	50/0.97	38/0.96
	1/2"	7/8"	25/1.00	50/0.99	50/0.98	50/0.98	50/0.97	50/0.96

NOTES:

- 1) Do not exceed 150 ft. linear line length.
- 2) *Do not exceed 50 ft. vertical separation between indoor and outdoor units.
- 3) **3/4" suction line should only be used for 2 ton systems if outdoor unit is below or at same level as indoor unit to assure proper oil return.
- 4) Always use the smallest liquid line allowable to minimize refrigerant charge.
- 5) Applications shaded in light gray indicate capacity multipliers between 0.90 and 0.96 which are not recommended, but are allowed.
- 6) Applications shaded in dark gray are not recommended due to excessive liquid or suction pressure drop.

[] Designates Metric Conversions

Refrigerant Line Size Information

15/16 SEER2 Variable Speed Air Conditioners								
Unit Size	Allowable Liquid Line Size	Allowable Vapor Line Size	Outdoor Unit ABOVE or BELOW Indoor Unit Equivalent Length (Meters)					
			< 25	26-50	51-75	76-100	101-125	126-150
			Maximum Vertical Separation / Capacity Multiplier					
2.0 Ton **SEE NOTE 3	6.35 [1/4]	15.88 [5/8]	8/1.00	15/0.99	10/0.98	10/0.97	NR	NR
	7.94 [5/16]	15.88 [5/8]	8/1.00	15/0.99	15/0.98	15/0.97	15/0.96	15/0.95
	9.53 [3/8]	15.88 [5/8]	8/1.00	15/0.99	15/0.98	15/0.97	15/0.96	15/0.95
	6.35 [1/4]	19.05 [3/4]**	8/1.00	15/0.99	10/0.99	12/0.99	NR	NR
	7.94 [5/16]	19.05 [3/4]**	8/1.00	15/0.99	15/0.99	15/0.99	15/0.99	15/0.98
	9.53 [3/8]	19.05 [3/4]**	8/1.00	15/0.99	15/0.99	15/0.99	15/0.99	15/0.98
3 Ton	7.94 [5/16]	15.88 [5/8]	8/0.99	15/0.97	15/0.95	15/0.93	11/0.91	NR
	9.53 [3/8]	15.88 [5/8]	8/0.99	15/0.97	15/0.95	15/0.93	15/0.91	NR
	7.94 [5/16]	19.05 [3/4]	8/1.00	15/0.99	15/0.99	15/0.98	11/0.97	7/0.96
	9.53 [3/8]	19.05 [3/4]	8/1.00	15/0.99	15/0.99	15/0.98	15/0.97	15/0.96
	12.7 [1/2]	19.05 [3/4]	8/1.00	15/0.99	15/0.99	15/0.98	15/0.97	15/0.96
4 Ton	9.53 [3/8]	19.05 [3/4]	8/0.99	15/0.98	15/0.97	15/0.96	15/0.94	15/0.93
	12.7 [1/2]	19.05 [3/4]	8/0.99	15/0.98	15/0.97	15/0.96	15/0.94	15/0.93
	9.53 [3/8]	22.23 [7/8]	8/1.00	15/0.99	15/0.99	15/0.98	15/0.98	15/0.97
	12.7 [1/2]	22.23 [7/8]	8/1.00	15/0.99	15/0.99	15/0.98	15/0.98	15/0.97
5 Ton	9.53 [3/8]	19.05 [3/4]	8/0.99	15/0.97	15/0.95	15/0.93	15/0.91	NR
	12.7 [1/2]	19.05 [3/4]	8/0.99	15/0.97	15/0.95	15/0.93	15/0.91	NR
	9.53 [3/8]	22.23 [7/8]	8/1.00	15/0.99	15/0.98	15/0.98	15/0.97	12/0.96
	12.7 [1/2]	22.23 [7/8]	8/1.00	15/0.99	15/0.98	15/0.98	15/0.97	15/0.97

NOTES:

- 1) Do not exceed 46 meters linear line length.
- 2) *Do not exceed 15 meters vertical separation between indoor and outdoor units.
- 3) **19.05mm [3/4 in.] vapor line should only be used for 2 ton systems if outdoor unit is below or at same level as indoor unit to assure proper oil return.
- 4) Always use the smallest liquid line allowable to minimize refrigerant charge.
- 5) Applications shaded in light gray indicate capacity multipliers between 0.90 and 0.96 which are not recommended, but are allowed.
- 6) Applications shaded in dark gray are not recommended due to excessive liquid or suction pressure drop.

Additional Oil, Oz.											
Lineset Length	50	60	70	80	90	100	110	120	130	140	150
2T	N/A	N/A	N/A	N/A	N/A	1	2	3	5	6	7
3T	N/A	N/A	N/A	N/A	N/A	N/A	1	2	3	5	6
4T	N/A	N/A	N/A	N/A	N/A	N/A	N/A	N/A	N/A	N/A	N/A
5T	N/A	N/A	N/A	N/A	N/A	N/A	N/A	N/A	N/A	N/A	N/A

Performance Data @ AHRI Standard Conditions – Cooling

Designated Tested Combination (DTC)							
Outdoor Unit	Air Handler	Total Capacity BTU/H [kW]	Net Sensible BTU/H [kW]	Net Latent BTU/H [kW]	SEER2	EER2	Indoor CFM [L/s]
RA15AZ24AJ3	RH3VZ2417STACN	22,800 [6.7]	17,600 [5.2]	5,200 [1.5]	15.2	9.8	750 [354.0]
RA15AZ36AJ3	RH3VZ3617STACN	34,200 [10.0]	26,600 [7.8]	7,600 [2.2]	15.2	9.8	1,125 [530.9]
RA15AZ48AJ3	RH3VZ4821STACN	45,500 [13.3]	35,500 [10.4]	10,000 [2.9]	15.2	9.8	1,425 [672.5]
RA15AZ60AJ3	RH3VZ6024STACN	55,500 [16.3]	43,000 [12.6]	12,500 [3.7]	15.2	9.8	1,675 [790.5]

NOTE: This data includes DTC (Designated Test Combination) ratings and is for reference purposes only. A full listing of official ratings and system match-ups, along with downloadable certificates, can be accessed from the AHRI website: www.ahridirectory.org.

[] Designates Metric Conversions



The new degree of comfort.®

Endeavor™ Line *Classic Plus*® Series iM Air Conditioners



This product meets a stringent set of our internally defined sustainability standards



RA16AZ

EcoNet® Enabled

Cooling Efficiencies up to: 17 SEER2/10.5 EER2

Nominal Sizes: 2 to 5 Tons [7.0 to 17.6 kW]

Cooling Capacities: 23.5 kBTU to 56 kBTU [6.9 to 16.4 kW]



The Bluetooth® word mark and logos are registered trademarks owned by Bluetooth SIG, Inc. and any use of such marks by Rheem® is under license. Other trademarks and trade names are those of their respective owners.

Table of Contents

Features & Benefits	3
Model Number Identification	4
General Data/Electrical Data	5
Accessories	6
Unit Dimensions	7
Clearances	8
Control Wiring	9
Application Guidelines.....	9
Refrigerant Line Size Information	10-11
Performance Data	12
Smart Home Systems	13
Limited Warranty	16

Features and Benefits

- **EcoNet® Enabled:** Automatic system configuration and optimization
- **PlusOne® Diagnostics & Bluetooth®¹ Connectivity:** With the Rheem Contractor & EcoNet® Apps, built-in technology makes advanced set-up, monitoring, troubleshooting and repairing the product easier than ever before
- **PlusOne® Variable Speed Twin Rotary Compressor & Inverter Drive:** Features Inverter operation from 40 to 100% capacity with the EcoNet® Smart Thermostat
- **3-Speed Operation:** When installed with a 24V two-stage thermostat
- **Provides Precise Temperature Control:** Advanced humidity control and greater efficiency
- **Brushless DC Condenser Motors (BLDC):** Enhances reliability and allows for easier serviceability
- **Swept Wing Fan Technology:** Features quieter operation and improved unit acoustics
- **7mm Condenser Copper Coil:** Requires less refrigerant allowing for a smaller and lighter footprint while enhancing reliability
- **PlusOne® Expanded Valve Space:** 3 in. – 4in. – 5 in. service valve space—provides a minimum working area of 27-square inches for easier access
- **PlusOne® Triple Service Access:** 15 in. wide, industry leading corner service access, two fastener, removeable corner and individual louver panels—makes repairs easier and faster

¹The Bluetooth® word mark and logos are registered trademarks owned by Bluetooth SIG, Inc. and any use of such marks by Rheem® is under license. Other trademarks and trade names are those of their respective owners.

Air Conditioners

<u>R</u>	<u>A</u>	<u>16</u>	<u>A</u>	<u>Z</u>	<u>24</u>	<u>A</u>	<u>J</u>	<u>3</u>	<u>C</u>	<u>A</u>	<u>LHP</u>
Brand	Product Category	SEER2	Region	Refrigerant	Capacity BTU/HR	Major Series	Voltage	Type	Controls	Minor Series	Option Code
R - Rheem	A - Air Conditioners	16 - 16 SEER2	A - All	Z - R-410A	24 - 24,000 [7.03 kW] 36 - 36,000 [10.55 kW] 48 - 48,000 [14.07 kW] 60 - 60,000 [17.58 kW]	A - 1st Design	J - 1ph, 208-230/60	3 - 3+ Stage	C - Communicating	A - 1st Design	LHP - W/HLPC

[] Designates Metric Conversions

AVAILABLE MODELS	DESCRIPTION
RA16AZ24AJ3CA	Endeavor™ Line <i>Classic Plus</i> ® Series 2 ton EcoNet® Enabled 3+ Speed iM Air Conditioner – 208/230/1/60
RA16AZ36AJ3CA	Endeavor™ Line <i>Classic Plus</i> ® Series 3 ton EcoNet® Enabled 3+ Speed iM Air Conditioner – 208/230/1/60
RA16AZ48AJ3CA	Endeavor™ Line <i>Classic Plus</i> ® Series 4 ton EcoNet® Enabled 3+ Speed iM Air Conditioner – 208/230/1/60
RA16AZ60AJ3CA	Endeavor™ Line <i>Classic Plus</i> ® Series 5 ton EcoNet® Enabled 3+ Speed iM Air Conditioner – 208/230/1/60

STANDARD EQUIPMENT
R-410A Refrigerant
Scroll Compressor
Field Installed Filter Drier
Front Seating Service Valves
Internal Pressure Relief Valve
Internal Thermal Overload
Long Line capability
Low Ambient capability with Kit
3-4-5 Expanded Valve Space
Composite Basepan
2 Screw Control Box Access
15" Access to Internal Components
Quick release louver panel design
No fasteners to remove along bottom
Optimized Venturi Airflow
Single row condenser coil
Powder coated paint
Rust resistant screws
QR code
External gauge ports
Service trays

*5T Model SEER2: 15.5 SEER2

General Data				
MODEL NO.	RA16AZ24AJ3	RA16AZ36AJ3	RA16AZ48AJ3	RA16AZ60AJ3
Nominal Tonnage	2.0	3.0	4.0	5.0
Valve Connections				
Liquid Line O.D. – in.	3/8	3/8	3/8	3/8
Suction Line O.D. – in.	3/4	3/4	7/8	7/8
Refrigerant (R410A) furnished oz.¹	91	119	130	154
Compressor Type	Twin Rotary			
Outdoor Coil				
Net face area – Outer Coil	11.79	14.4	16.42	17.88
Net face area – Inner Coil	—	—	—	—
Tube diameter – in.	0.276	0.276	0.276	0.276
Number of rows	1	1	1	1
Fins per inch	24	24	24	24
Outdoor Fan				
Diameter – in.	20	24	24	26
Number of blades	3	3	3	3
Motor hp	1/5	1/5	1/3	1/2
CFM	2883	4138	4508	5348
RPM	1075	1000	1075	1075
watts	168	267	297	379
Shipping weight – lbs.	153	157	195	211
Operating weight – lbs.	146	150	188	204
Electrical Data				
Line Voltage Data (Volts-Phase-Hz)	208/230-1-60	208/230-1-60	208/230-1-60	208/230-1-60
Maximum overcurrent protection (amps)²	20	30	40	50
Minimum circuit ampacity³	12	20	25	32
Compressor				
Rated load amps	10	15	20	25
Locked rotor amps	65	70	96	119

¹Refrigerant charge sufficient for 15 ft. length of refrigerant lines. For longer line set requirements see the installation instructions for information about set length and additional refrigerant charge required.

²HACR type circuit breaker or fuse.

³Refer to National Electrical Code manual to determine wire, fuse and disconnect size requirements.

Accessories

MODEL NO.		RA16AZ24AJ3	RA16AZ36AJ3	RA16AZ48AJ3	RA16AZ60AJ3
Compressor crankcase heater*		X	X	X	X
Low ambient control		Factory Installed	Factory Installed	Factory Installed	Factory Installed
Compressor sound cover		Factory Installed	Factory Installed	Factory Installed	Factory Installed
Compressor hard start kit		Factory Installed	Factory Installed	Factory Installed	Factory Installed
Compressor time delay		Factory Installed	Factory Installed	Factory Installed	Factory Installed
Low pressure control		X	X	X	X
High pressure control		Factory Installed	Factory Installed	Factory Installed	Factory Installed
Liquid Line Solenoid (24 VAC, 50/60 Hz)	Solenoid Valve	200RD2T3TVLC	200RD2T3TVLC	200RD2T3TVLC	200RD2T3TVLC
	Solenoid Coil	61-AMG24V	61-AMG24V	61-AMG24V	61-AMG24V
Liquid Line Solenoid (120/240 VAC, 50/60 Hz)	Solenoid Valve	200RD2T3TVLC	200RD2T3TVLC	200RD2T3TVLC	200RD2T3TVLC
	Solenoid Coil	61-AMG120/240V	61-AMG120/240V	61-AMG120/240V	61-AMG120/240V

*Crankcase Heater recommended with Low Ambient Kit.

Weighted Sound Power Level (dBA)

UNIT SIZE - VOLTAGE, SERIES	STANDARD RATING (DBA)	TYPICAL OCTAVE BAND SPECTRUM (DBA WITHOUT TONE ADJUSTMENT)							SOUND POWER LEVEL (DB(A)) WITH SOUND BLANKET
		125	250	500	1000	2000	4000	8000	
RA16AZ24AJ3	63.3	35.9	47.9	55.3	53.2	50.4	47.1	43.8	Sound Blankets - Standard
	71.7	46.1	59.1	63.2	60.8	58.7	56.5	47.9	
RA16AZ36AJ3	61.4	38.5	48.0	53.8	49.2	45.9	47.0	47.4	
	72.9	47.5	59.5	64.9	60.7	62.6	57.0	49.6	
RA16AZ48AJ3	63.8	42.3	45.9	53.5	48.9	45.8	59.1	36.4	
	76.2	49.4	61.4	68.1	53.9	60.8	57.4	48.5	
RA16AZ60AJ3	65.7	39.7	49.0	58.2	54.5	52.2	53.8	41.3	
	76.7	49.3	64.6	68.1	65.1	62.6	58.6	53.0	

NOTE: Tested in accordance with AHRI Standard 270-08 (not listed in AHRI)

Unit Dimensions

MODEL NO.	OPERATING						SHIPPING					
	H (Height)		L (Length)		W (Width)		H (Height)		L (Length)		W (Width)	
	INCHES	mm	INCHES	mm	INCHES	mm	INCHES	mm	INCHES	mm	INCHES	mm
RA16AZ24AJ3	27.00	686	29.75	756	29.75	756	28.50	724	32.38	822	32.38	822
RA16AZ36AJ3	27.00	686	33.75	857	33.75	857	28.50	724	36.38	924	36.38	924
RA16AZ48AJ3	31.00	787	33.75	857	33.75	857	32.50	826	36.38	924	36.38	924
RA16AZ60AJ3	31.00	787	35.75	908	35.75	908	32.50	826	38.38	975	38.38	975

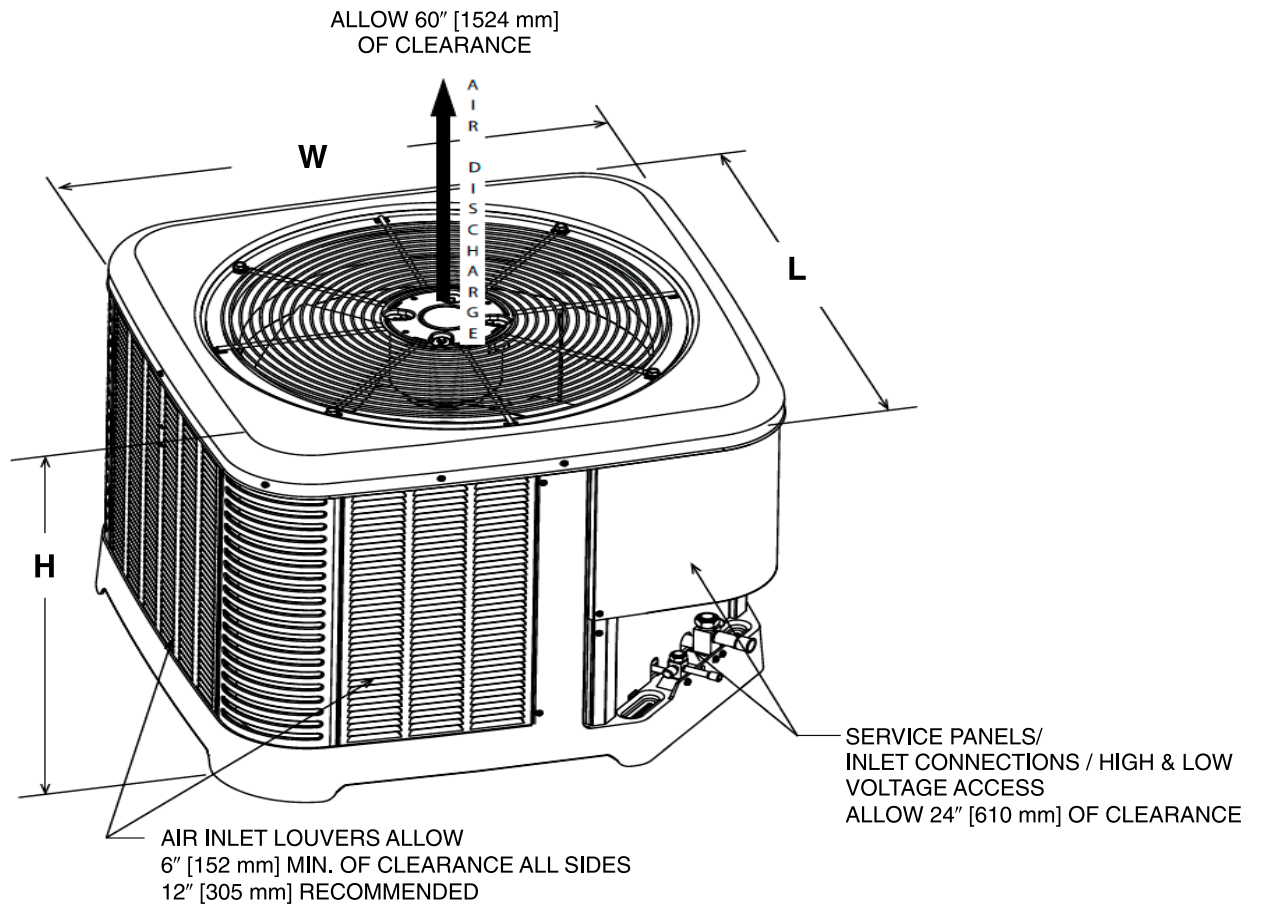

[] Designates Metric Conversions

ST-A1226-02-00

CLEARANCES

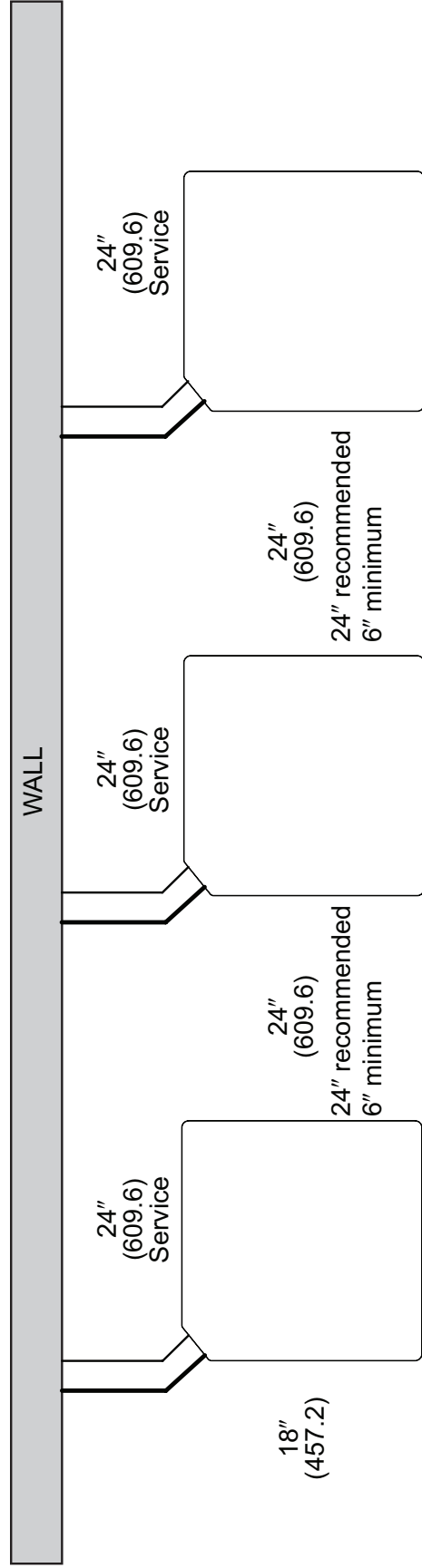
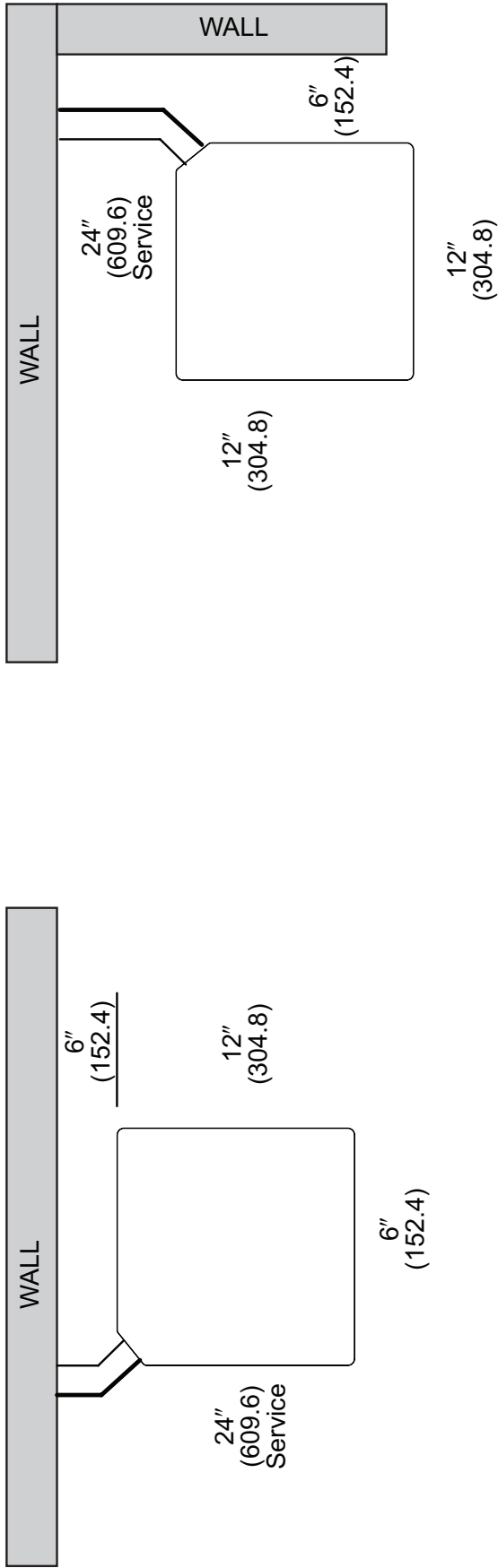

NOTE: NUMBERS IN () = mm

IMPORTANT: When installing multiple units in an alcove, roof well or partially enclosed area, ensure there is adequate ventilation to prevent re-circulation of discharge air.

Control Wiring

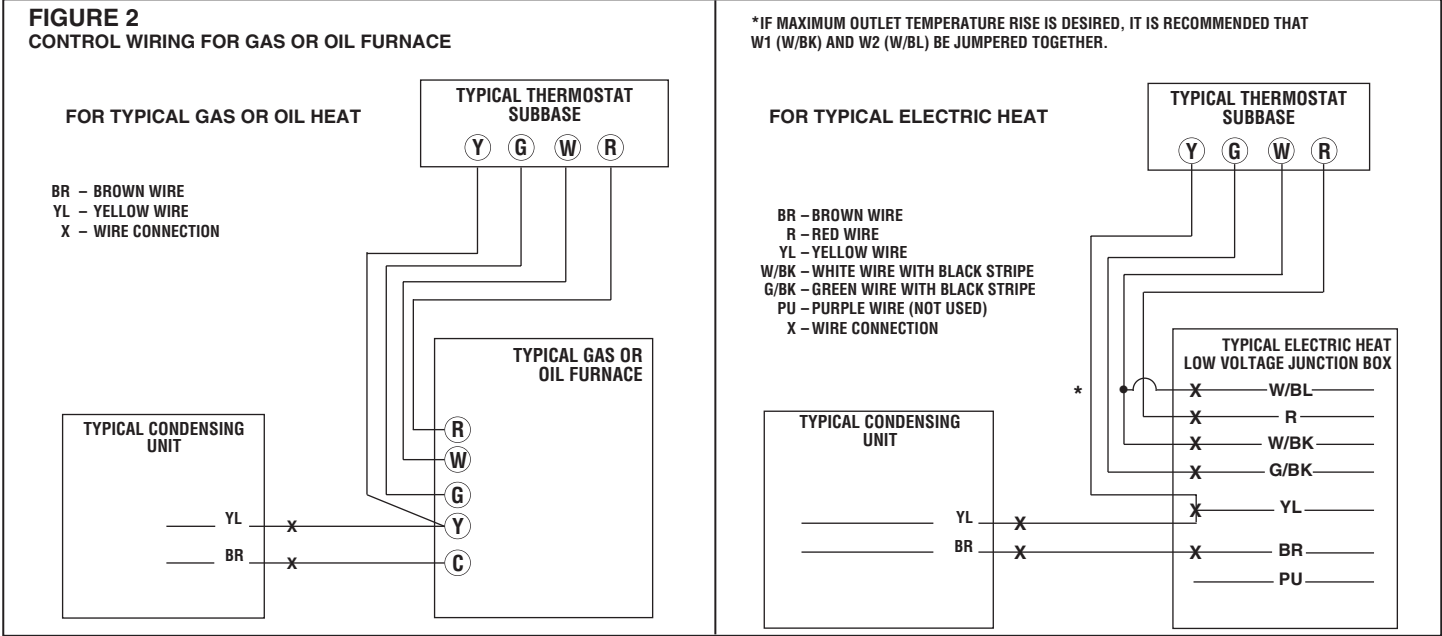

Application Guidelines

1. Intended for outdoor installation with free air inlet and outlet. Outdoor fan external static pressure available is less than 0.01 -in. wc.
2. Minimum outdoor operation air temperature for cooling mode without low-ambient operation accessory is 55°F (12.8°C).
3. Maximum outdoor operating air temperature is 125°F (51.7°C).
4. For reliable operation, unit should be level in all horizontal planes.
5. Use only copper wire for electric connections at unit. Aluminum and clad aluminum are not acceptable for the type of connector provided.
6. Do not apply capillary tube indoor coils to these units.
7. Factory-supplied filter drier must be installed.

Refrigerant Line Size Information

15/16 SEER2 VARIABLE SPEED AIR CONDITIONERS								
UNIT SIZE	ALLOWABLE LIQUID LINE SIZE	ALLOWABLE VAPOR LINE SIZE	OUTDOOR UNIT ABOVE OR BELOW INDOOR UNIT EQUIVALENT LENGTH (FEET)					
			< 25	26-50	51-75	76-100	101-125	126-150
			MAXIMUM VERTICAL SEPARATION / CAPACITY MULTIPLIER					
2.0 Ton **SEE NOTE 3	1/4"	5/8"	25/1.00	50/0.99	32/0.98	40/0.97	NR	NR
	5/16"	5/8"	25/1.00	50/0.99	50/0.98	50/0.97	50/0.96	50/0.95
	3/8"	5/8"	25/1.00	50/0.99	50/0.98	50/0.97	50/0.96	50/0.95
	1/4"	3/4"	25/1.00	50/1.00	32/0.99	40/0.99	NR	NR
	5/16"	3/4"	25/1.00	50/1.00	50/0.99	50/0.99	50/0.99	50/0.98
	3/8"	3/4"	25/1.00	50/1.00	50/0.99	50/0.99	50/0.99	50/0.98
3 Ton	5/16"	5/8"	25/0.99	50/0.97	50/0.95	50/0.93	37/0.91	NR
	3/8"	5/8"	25/0.99	50/0.97	50/0.95	50/0.93	50/0.91	NR
	5/16"	3/4"	25/1.00	50/0.99	50/0.99	50/0.98	37/0.97	22/0.96
	3/8"	3/4"	25/1.00	50/0.99	50/0.99	50/0.98	50/0.97	50/0.96
	1/2"	3/4"	25/1.00	50/0.99	50/0.99	50/0.98	50/0.97	50/0.96
4 Ton	3/8"	3/4"	25/0.99	50/0.98	50/0.97	50/0.96	50/0.94	50/0.93
	1/2"	3/4"	25/0.99	50/0.98	50/0.97	50/0.96	50/0.94	50/0.93
	3/8"	7/8"	25/1.00	50/0.99	50/0.99	50/0.98	50/0.98	50/0.97
	1/2"	7/8"	25/1.00	50/0.99	50/0.99	50/0.98	50/0.98	50/0.97
5 Ton	3/8"	3/4"	25/0.99	50/0.97	50/0.95	50/0.93	50/0.91	NR
	1/2"	3/4"	25/0.99	50/0.97	50/0.95	50/0.93	50/0.91	NR
	3/8"	7/8"	25/1.00	50/0.99	50/0.98	50/0.98	50/0.97	38/0.96
	1/2"	7/8"	25/1.00	50/0.99	50/0.98	50/0.98	50/0.97	50/0.96

NOTES:

- 1) Do not exceed 150 ft. linear line length.
- 2) *Do not exceed 50 ft. vertical separation if outdoor unit is above indoor unit.
- 3) **3/4" suction line should only be used for 2 ton systems if outdoor unit is below or at same level as indoor to assure proper oil return.
- 4) Always use the smallest liquid line allowable to minimize refrigerant charge.
- 5) Applications shaded in light gray indicate capacity multipliers between 0.90 and 0.96 which are not recommended, but are allowed.
- 6) Applications shaded in dark gray are not recommended due to excessive liquid or suction pressure drop.

Refrigerant Line Size Information (Con't.)

15/16 SEER2 VARIABLE SPEED AIR CONDITIONERS								
UNIT SIZE	ALLOWABLE LIQUID LINE SIZE	ALLOWABLE VAPOR LINE SIZE	OUTDOOR UNIT ABOVE OR BELOW INDOOR UNIT EQUIVALENT LENGTH (METERS)					
			< 25	26-50	51-75	76-100	101-125	126-150
			MAXIMUM VERTICAL SEPARATION / CAPACITY MULTIPLIER					
2.0 Ton **SEE NOTE 3	6.35 [1/4]	15.88 [5/8]	8/1.00	15/0.99	10/0.98	10/0.97	NR	NR
	7.94 [5/16]	15.88 [5/8]	8/1.00	15/0.99	15/0.98	15/0.97	15/0.96	15/0.95
	9.53 [3/8]	15.88 [5/8]	8/1.00	15/0.99	15/0.98	15/0.97	15/0.96	15/0.95
	6.35 [1/4]	19.05 [3/4]**	8/1.00	15/0.99	10/0.99	12/0.99	NR	NR
	7.94 [5/16]	19.05 [3/4]**	8/1.00	15/0.99	15/0.99	15/0.99	15/0.99	15/0.98
	9.53 [3/8]	19.05 [3/4]**	8/1.00	15/0.99	15/0.99	15/0.99	15/0.99	15/0.98
3 Ton	7.94 [5/16]	15.88 [5/8]	8/0.99	15/0.97	15/0.95	15/0.93	11/0.91	NR
	9.53 [3/8]	15.88 [5/8]	8/0.99	15/0.97	15/0.95	15/0.93	15/0.91	NR
	7.94 [5/16]	19.05 [3/4]	8/1.00	15/0.99	15/0.99	15/0.98	11/0.97	7/0.96
	9.53 [3/8]	19.05 [3/4]	8/1.00	15/0.99	15/0.99	15/0.98	15/0.97	15/0.96
	12.7 [1/2]	19.05 [3/4]	8/1.00	15/0.99	15/0.99	15/0.98	15/0.97	15/0.96
4 Ton	9.53 [3/8]	19.05 [3/4]	8/0.99	15/0.98	15/0.97	15/0.96	15/0.94	15/0.93
	12.7 [1/2]	19.05 [3/4]	8/0.99	15/0.98	15/0.97	15/0.96	15/0.94	15/0.93
	9.53 [3/8]	22.23 [7/8]	8/1.00	15/0.99	15/0.99	15/0.98	15/0.98	15/0.97
	12.7 [1/2]	22.23 [7/8]	8/1.00	15/0.99	15/0.99	15/0.98	15/0.98	15/0.97
5 Ton	9.53 [3/8]	19.05 [3/4]	8/0.99	15/0.97	15/0.95	15/0.93	15/0.91	NR
	12.7 [1/2]	19.05 [3/4]	8/0.99	15/0.97	15/0.95	15/0.93	15/0.91	NR
	9.53 [3/8]	22.23 [7/8]	8/1.00	15/0.99	15/0.98	15/0.98	15/0.97	12/0.96
	12.7 [1/2]	22.23 [7/8]	8/1.00	15/0.99	15/0.98	15/0.98	15/0.97	15/0.97

NOTES:

- 1) Do not exceed 46 meters linear line length.
- 2) *Do not exceed 15 meters vertical separation between indoor and outdoor units.
- 3) **19.05mm [3/4"] vapor line should only be used for 2 ton systems if outdoor unit is below or at same level as indoor unit to assure proper oil return.
- 4) Always use the smallest liquid line allowable to minimize refrigerant charge.
- 5) Applications shaded in light gray indicate capacity multipliers between 0.90 and 0.96 which are not recommended, but are allowed.
- 6) Applications shaded in dark gray are not recommended due to excessive liquid or suction pressure drop.

ADDITIONAL OIL, OZ.											
LINESET LENGTH	50	60	70	80	90	100	110	120	130	140	150
2T	N/A	N/A	N/A	N/A	N/A	1	2	3	5	6	7
3T	N/A	N/A	N/A	N/A	N/A	N/A	1	2	3	5	6
4T	N/A	N/A	N/A	N/A	N/A	N/A	N/A	N/A	N/A	N/A	N/A
5T	N/A	N/A	N/A	N/A	N/A	N/A	N/A	N/A	N/A	N/A	N/A

Performance Data @ AHRI Standard Conditions – Cooling

DESIGNATED TESTED COMBINATION (DTC)							
OUTDOOR UNIT	INDOOR COIL	TOTAL CAPACITY BTU/H [KW]	NET SENSIBLE BTU/H [KW]	NET LATENT BTU/H [KW]	SEER2	EER2	INDOOR CFM [L/S]
RA16AZ24AJ3C	RH3VZ2417STACN	22,800 [6.7]	17,600 [5.2]	5,200 [1.5]	16.0	10.5	750 [354.0]
RA16AZ36AJ3C	RH3VZ3617STACN	34,200 [10.0]	26,600 [7.8]	7,600 [2.2]	16.0	10.5	1,125 [530.9]
RA16AZ48AJ3C	RH3VZ4821STACN	45,500 [13.3]	35,500 [10.4]	10,000 [2.9]	16.0	10.5	1,425 [672.5]
RA16AZ60AJ3C	RH3VZ6024STACN	55,500 [16.3]	43,000 [12.6]	12,500 [3.7]	15.5	9.8	1,675 [790.5]

NOTE: This data includes DTC (Designated Test Combination) ratings and is for reference purposes only. A full listing of official ratings and system match-ups, along with downloadable certificates, can be accessed from the AHRI website: www.ahridirectory.org.

[] Designates Metric Conversions



The new degree of comfort.®

Endeavor™ Line Prestige® Series iM Air Conditioners



This product meets a stringent set of our internally defined sustainability standards

RA18AZ

EcoNet® Enabled

Cooling Efficiencies up to: 20.0 SEER2/13 EER2

Nominal Sizes: 2 to 5 Tons [7.0 to 17.6 kW]

Cooling Capacities: 22.8 to 54 kBTU [6.7 to 15.83 kW]



****Proper sizing and installation of equipment is critical to achieve optimal performance. Split system air conditioners and heat pumps must be matched with appropriate coil components to meet Energy Star. Ask your Contractor for details or visit www.energystar.gov.***

The Bluetooth® word mark and logos are registered trademarks owned by Bluetooth SIG, Inc. and any use of such marks by Rheem® is under license. Other trademarks and trade names are those of their respective owners.

Table of Contents

Features & Benefits	3
Model Number Identification	4
General Data/Electrical Data	5
Accessories	6
Weighted Sound Power	6
Unit Dimensions	7
Clearances	8
Control Wiring	9
Application Guidelines.....	9
Refrigerant Line Size Information	10-11
Performance Data	12
Smart Home Systems	13
Limited Warranty	16

Features and Benefits

- **EcoNet® Enabled:** Automatic system configuration and optimization
- **PlusOne® Diagnostics & Bluetooth Connectivity:** With the Rheem Contractor & EcoNet® Apps, built-in technology makes advanced set-up, monitoring, troubleshooting, and repairing the product easier than ever before
- **Brushless DC Condenser Motors (BLDC):** Enhances reliability and allows for easier serviceability
- **Swept Wing Fan Technology:** Features quieter operation and improved unit acoustics
- **PlusOne® Expanded Valve Space:** 3 in. – 4 in. – 5 in. service valve space—provides a minimum working area of 27-square inches for easier access
- **PlusOne® Triple Service Access:** 15 in. wide, industry leading corner service access, two fastener, removeable corner and individual louver panels – makes repairs easier and faster

Air Conditioners

<u>R</u>	<u>A</u>	<u>18</u>	<u>A</u>	<u>Z</u>	<u>24</u>	<u>A</u>	<u>J</u>	<u>V</u>	<u>C</u>	<u>A</u>
Brand	Product Category	SEER2	Region	Refrigerant	Capacity BTU/HR	Major Series	Voltage	Type	Controls	Minor Series
R - Rheem	A - Air Conditioners	18 - 18 SEER2	A - All	Z - R-410A	24 - 24,000 [7.03 kW] 36 - 36,000 [10.55 kW] 48 - 48,000 [14.07 kW] 60 - 60,000 [17.58 kW]	A - 1st Design	J - 1ph, 208-230/60	V - Inverter	C - Communicating	A - 1st Design

[] Designates Metric Conversions

AVAILABLE MODELS	DESCRIPTION
RA18AZ24AJVCA	Endeavor™ Line <i>Prestige</i> ® Series 2 ton EcoNet® Enabled Inverter Driven Variable Speed iM Air Conditioner - 208/230/1/60
RA18AZ36AJVCA	Endeavor™ Line <i>Prestige</i> ® Series 3 ton EcoNet® Enabled Inverter Driven Variable Speed iM Air Conditioner - 208/230/1/60
RA18AZ48AJVCA	Endeavor™ Line <i>Prestige</i> ® Series 4 ton EcoNet® Enabled Inverter Driven Variable Speed iM Air Conditioner - 208/230/1/60
RA18AZ60AJVCA	Endeavor™ Line <i>Prestige</i> ® Series 5 ton EcoNet® Enabled Inverter Driven Variable Speed iM Air Conditioner - 208/230/1/60

STANDARD EQUIPMENT
R-410A Refrigerant
EcoNet® Enabled
Variable Speed Compressor
Compressor Sound Blanket
Variable speed outdoor fan motor
Swept wing fan blade
Field Installed Filter Drier
Front Seating Service Valves
Internal Pressure Relief Valve
Internal Thermal Overload
Low Ambient capability
3-4-5 Expanded Valve Space
Composite Basepan
1" Screw Control Box Access
15" Access to Internal Components
Quick release louver panel design
No fasteners to remove along bottom
Optimized Venturi Airflow
Single row condenser coil ¹
Powder coated paint
Rust resistant screws
QR code
External gauge ports
Service trays

¹5 Ton model includes 2 row condenser coil

General Data				
GENERAL DATA				
MODEL NO.	RA18AZ24AJVCA	RA18AZ36AJVCA	RA18AZ48AJVCA	RA18AZ60AJVCA
Nominal Tonnage	2.0	3.0	4.0	5.0
Valve Connections				
Liquid Line O.D. – in.	3/8	3/8	3/8	3/8
Suction Line O.D. – in.	3/4	3/4	7/8	7/8
Refrigerant (R410A) furnished oz.¹	210	212	222	252
Compressor Type	Scroll			
Outdoor Coil				
Net face area – Outer Coil	22.2	22.3	32.5	32.5
Net face area – Inner Coil	—	—	—	32.5
Tube diameter – in.	0.375	0.375	0.375	0.375
Number of rows	1	1	1	2
Fins per inch	20	20	22	20
Outdoor Fan				
Diameter – in.	24	24	26	26
Number of blades	3	3	3	3
Motor hp	1/5	1/3	1/2	1/2
CFM	3330	4315	6240	6175
RPM	772	825	935	900
watts	83	114	278	278
Shipping weight – lbs.	226	244	263	316
Operating weight – lbs.	214	236	255	307
Electrical Data				
Line Voltage Data (Volts-Phase-Hz)	208/230-1-60	208/230-1-60	208/230-1-60	208/230-1-60
Maximum overcurrent protection (amps)²	35	45	70	80
Minimum circuit ampacity³	21	29	46	48
Compressor				
Rated load amps	15	20.1	32	34.1
Locked rotor amps	35	35	50	50

¹Refrigerant charge sufficient for 15 ft. length of refrigerant lines. For longer line set requirements see the installation instructions for information about set length and additional refrigerant charge required.

²HACR type circuit breaker or fuse.

³Refer to National Electrical Code manual to determine wire, fuse and disconnect size requirements.

Accessories

MODEL NO.	RA18AZ24JVCA	RA18AZ36JVCA	RA18AZ48JVCA	RA18AZ60JVCA
EcoNet® Smart Thermostat	RETST800SYS	RETST800SYS	RETST800SYS	RETST800SYS
Compressor Sound Cover	STD	STD	STD	STD
Supply / Return Sensor	RXHT-A02	RXHT-A02	RXHT-A02	RXHT-A02

Weighted Sound Power Level

MODEL	SOUND POWER LEVEL [DB(A)] LOW SPEED/ HIGH SPEED	FULL OCTAVE LINEAR SOUND POWER LEVEL DB - CENTER FREQUENCY - HZ							SOUND POWER LEVEL [DB(A)] WITH SOUND BLANKET
		125	250	500	1000	2000	4000	8000	
RA18AZ24JVCA	58.9	29	36.5	42	45.7	42.3	43.2	33	Sound Blankets - Standard
	68	47.1	47.7	58.8	57.1	55.0	52.7	45.6	
RA18AZ36JVCA	57	29.2	36.7	44.9	45.4	42.2	39.4	32.2	
	72	42.9	52.8	62.7	63.6	58.7	54.1	52.4	
RA18AZ48JVCA	54	30.6	39	42.2	42.5	36.5	35.2	35	
	72	48.2	55.3	64.6	61.7	56.2	51.7	46.2	
RA18AZ60JVCA	70	46.6	50.5	62.7	52.9	49.4	46	41.4	
	76	50.7	62.7	67.7	65.4	64.2	59.2	54.9	

NOTE: Tested in accordance with AHRI Standard 270-08 (not listed in AHRI)

Unit Dimensions

MODEL NO.	OPERATING						SHIPPING					
	H (Height)		L (Length)		W (Width)		H (Height)		L (Length)		W (Width)	
	INCHES	mm	INCHES	mm	INCHES	mm	INCHES	mm	INCHES	mm	INCHES	mm
RA18AZ24AJVCA	39	990	33.75	857	33.75	857	41.56	1055	37.64	956	37.56	954
RA18AZ36AJVCA	39	990	33.75	857	33.75	857	41.56	1055	37.64	956	37.56	954
RA18AZ48AJVCA	51	1295	35.75	908	35.75	908	53.56	1360	39.37	999	39.64	1006
RA18AZ60AJVCA	51	1295	35.75	908	35.75	908	53.56	1360	39.37	999	39.64	1006

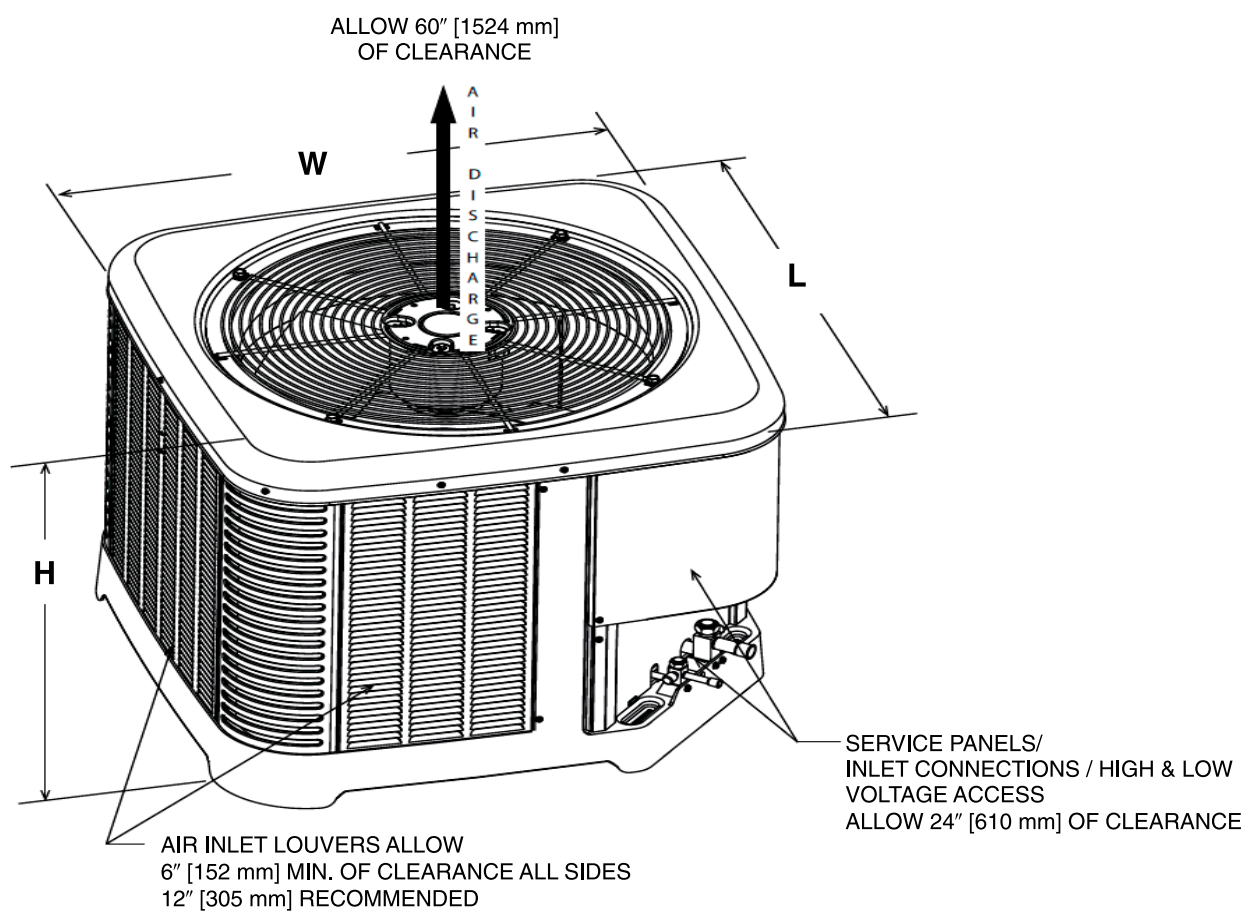

[] Designates Metric Conversions

ST-A1226-02-00

CLEARANCES

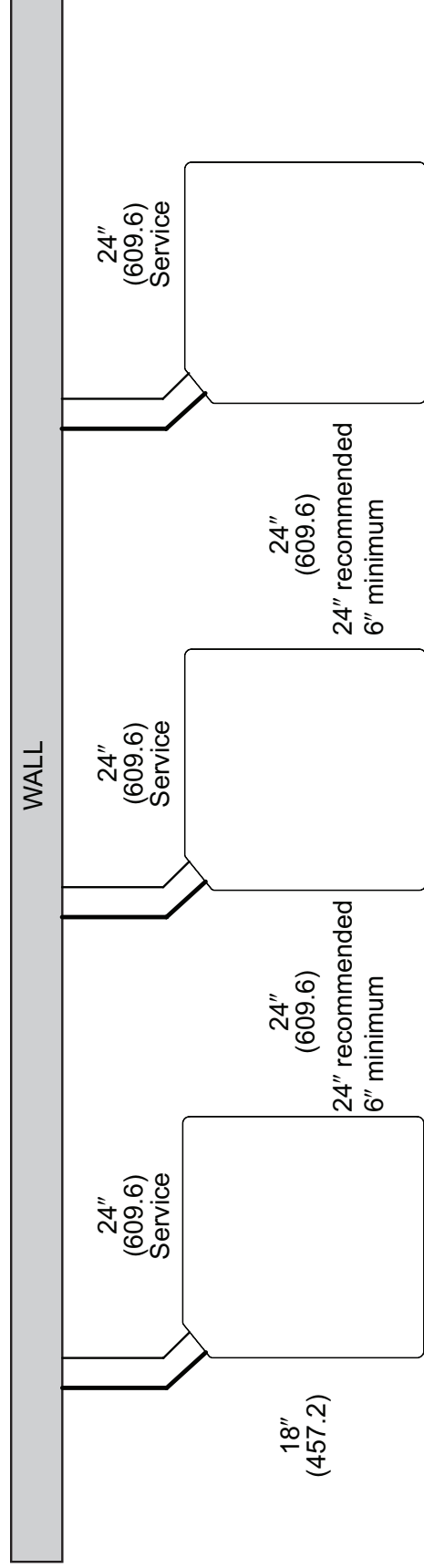
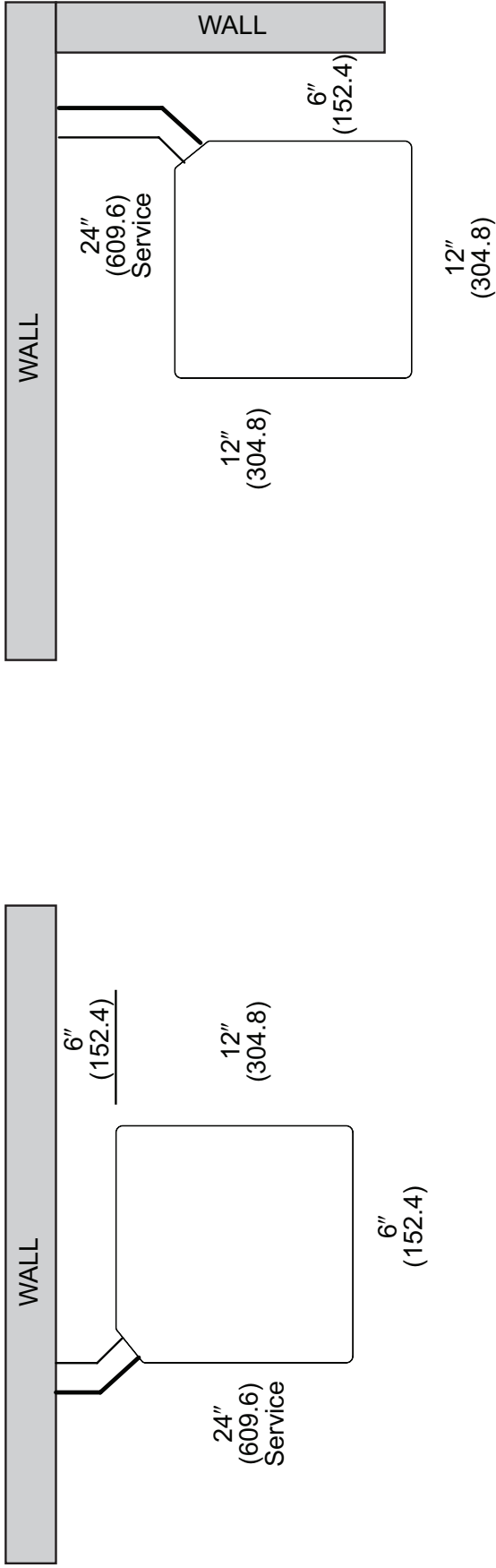

NOTE: NUMBERS IN () = mm

IMPORTANT: When installing multiple units in an alcove, roof well or partially enclosed area, ensure there is adequate ventilation to prevent re-circulation of discharge air.

Control Wiring

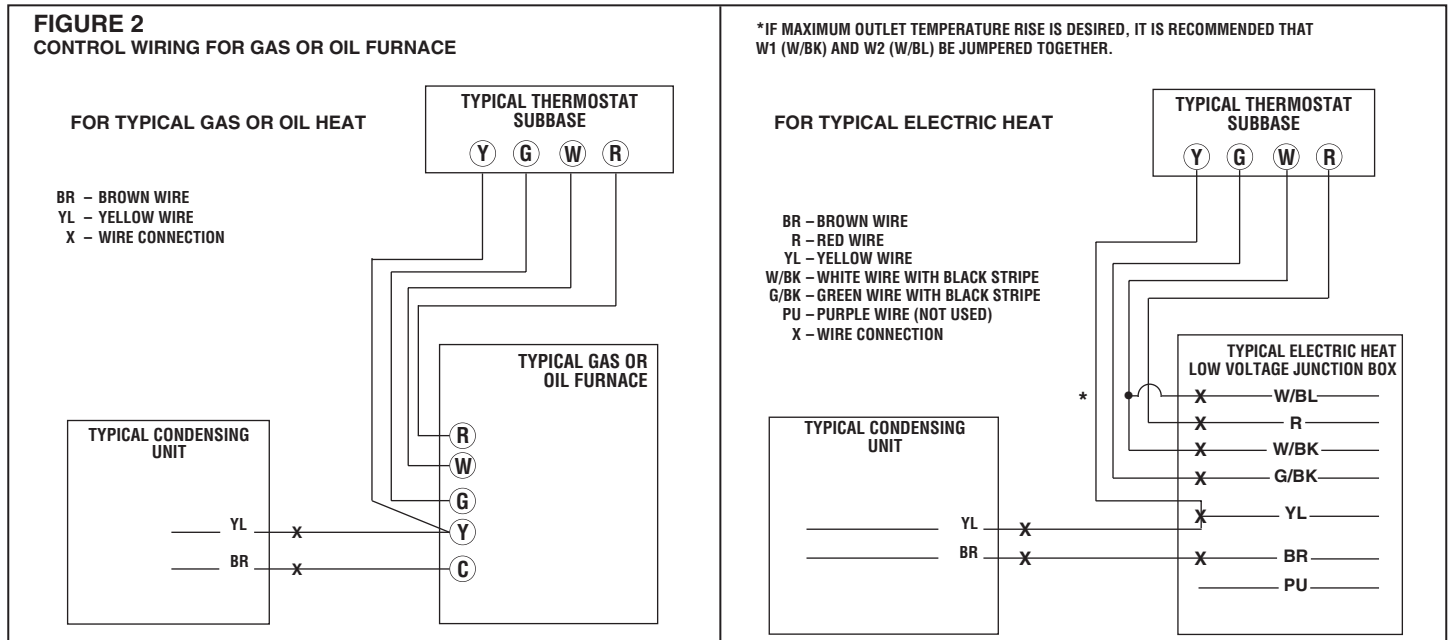

Application Guidelines

1. Intended for outdoor installation with free air inlet and outlet. Outdoor fan external static pressure available is less than 0.01 in. wc.
2. Minimum outdoor operation air temperature for cooling mode without low-ambient operation accessory is 55°F (12.8°C).
3. Maximum outdoor operating air temperature is 125°F (51.7°C).
4. For reliable operation, unit should be level in all horizontal planes.
5. Use only copper wire for electric connections at unit. Aluminum and clad aluminum are not acceptable for the type of connector provided.
6. Do not apply capillary tube indoor coils to these units.
7. Factory-supplied filter drier must be installed.

Refrigerant Line Size Information

18 SEER2 VARIABLE SPEED AIR CONDITIONERS								
UNIT SIZE	ALLOWABLE LIQUID LINE SIZE	ALLOWABLE VAPOR LINE SIZE	OUTDOOR UNIT ABOVE OR BELOW INDOOR UNIT EQUIVALENT LENGTH (FEET)					
			< 25	26-50	51-75	76-100	101-125	126-150
			MAXIMUM VERTICAL SEPARATION/CAPACITY MULTIPLIER					
2 Ton* SEE NOTE 3	1/4"	5/8"	25/1.00	50/0.99	32/0.98	40/0.97	NR	NR
	5/16"	5/8"	25/1.00	50/0.99	50/0.98	50/0.97	50/0.96	50/0.95
	3/8"	5/8"	25/1.00	50/0.99	50/0.98	50/0.97	50/0.96	50/0.95
	1/4"	3/4"	25/1.00	50/1.00	32/0.99	40/0.99	NR	NR
	5/16"	3/4"	25/1.00	50/1.00	50/0.99	50/0.99	50/0.99	50/0.98
	3/8"	3/4"	25/1.00	50/1.00	50/0.99	50/0.99	50/0.99	50/0.98
3 Ton	5/16"	5/8"	25/0.99	50/0.97	50/0.95	50/0.93	37/0.91	NR
	3/8"	5/8"	25/0.99	50/0.97	50/0.95	50/0.93	50/0.91	NR
	5/16"	3/4"	25/1.00	50/0.99	50/0.99	50/0.98	37/0.97	22/0.96
	3/8"	3/4"	25/1.00	50/0.99	50/0.99	50/0.98	50/0.97	50/0.96
	1/2"	3/4"	25/1.00	50/0.99	50/0.99	50/0.98	50/0.97	50/0.96
4 Ton	3/8"	3/4"	25/0.99	50/0.98	50/0.97	50/0.96	50/0.94	50/0.93
	1/2"	3/4"	25/0.99	50/0.98	50/0.97	50/0.96	50/0.94	50/0.93
	3/8"	7/8"	25/1.00	50/0.99	50/0.99	50/0.98	50/0.98	50/0.97
	1/2"	7/8"	25/1.00	50/0.99	50/0.99	50/0.98	50/0.98	50/0.97
5 Ton	3/8"	3/4"	25/0.99	50/0.97	50/0.95	50/0.93	50/0.91	NR
	1/2"	3/4"	25/0.99	50/0.97	50/0.95	50/0.93	50/0.91	NR
	3/8"	7/8"	25/1.00	50/0.99	50/0.98	50/0.98	50/0.97	38/0.96
	1/2"	7/8"	25/1.00	50/0.99	50/0.98	50/0.98	50/0.97	50/0.96

NOTES:

- 1) Do not exceed 150 ft linear line length.
- 2) *Do not exceed 50 ft vertical separation between indoor and outdoor units.
- 3) **3/4" suction line should only be used for 2 ton systems if outdoor unit is below or at same level as indoor unit to assure proper oil return.
- 4) Always use the smallest liquid line allowable to minimize refrigerant charge.
- 5) Applications shaded in light gray indicate capacity multipliers between 0.90 and 0.96 which are not recommended, but are allowed.
- 6) Applications shaded in dark gray are not recommended due to excessive liquid or suction pressure drop.

[] Designates Metric Conversions

Refrigerant Line Size Information (Con't.)

18 SEER2 VARIABLE SPEED AIR CONDITIONERS								
UNIT SIZE	ALLOWABLE LIQUID LINE SIZE	ALLOWABLE VAPOR LINE SIZE	OUTDOOR UNIT ABOVE OR BELOW INDOOR UNIT EQUIVALENT LENGTH (METERS)					
			< 8	8-15	16-23	24-30	31-38	39-46
			MAXIMUM VERTICAL SEPARATION/CAPACITY MULTIPLIER					
2 Ton* SEE NOTE 3	6.35 [1/4]	15.88 [5/8]	8/1.00	15/0.99	10/0.98	10/0.97	NR	NR
	7.94 [5/16]	15.88 [5/8]	8/1.00	15/0.99	15/0.98	15/0.97	15/0.96	15/0.95
	9.53 [3/8]	15.88 [5/8]	8/1.00	15/0.99	15/0.98	15/0.97	15/0.96	15/0.95
	6.35 [1/4]	19.05 [3/4]**	8/1.00	15/0.99	10/0.99	12/0.99	NR	NR
	7.94 [5/16]	19.05 [3/4]**	8/1.00	15/0.99	15/0.99	15/0.99	15/0.99	15/0.98
	9.53 [3/8]	19.05 [3/4]**	8/1.00	15/0.99	15/0.99	15/0.99	15/0.99	15/0.98
3 Ton	7.94 [5/16]	15.88 [5/8]	8/0.99	15/0.97	15/0.95	15/0.93	11/0.91	NR
	9.53 [3/8]	15.88 [5/8]	8/0.99	15/0.97	15/0.95	15/0.93	15/0.91	NR
	7.94 [5/16]	19.05 [3/4]	8/1.00	15/0.99	15/0.99	15/0.98	11/0.97	7/0.96
	9.53 [3/8]	19.05 [3/4]	8/1.00	15/0.99	15/0.99	15/0.98	15/0.97	15/0.96
	12.70 [1/2]	19.05 [3/4]	8/1.00	15/0.99	15/0.99	15/0.98	15/0.97	15/0.96
4 Ton	9.53 [3/8]	19.05 [3/4]	8/0.99	15/0.98	15/0.97	15/0.96	15/0.94	15/0.93
	12.70 [1/2]	19.05 [3/4]	8/0.99	15/0.98	15/0.97	15/0.96	15/0.94	15/0.93
	9.53 [3/8]	22.23 [7/8]	8/1.00	15/0.99	15/0.99	15/0.98	15/0.98	15/0.97
	12.70 [1/2]	22.23 [7/8]	8/1.00	15/0.99	15/0.99	15/0.98	15/0.98	15/0.97
5 Ton	9.53 [3/8]	19.05 [3/4]	8/0.99	15/0.97	15/0.95	15/0.93	15/0.91	NR
	12.70 [1/2]	19.05 [3/4]	8/0.99	15/0.97	15/0.95	15/0.93	15/0.91	NR
	9.53 [3/8]	22.23 [7/8]	8/1.00	15/0.99	15/0.98	15/0.98	15/0.97	12/0.96
	12.70 [1/2]	22.23 [7/8]	8/1.00	15/0.99	15/0.98	15/0.98	15/0.97	15/0.97

NOTES:

- 1) Do not exceed 46 meters linear line length.
- 2) *Do not exceed 15 meters vertical separation between indoor and outdoor units.
- 3) **19.05mm [3/4 in.] vapor line should only be used for 2 ton systems if outdoor unit is below or at same level as indoor unit to assure proper oil return.
- 4) Always use the smallest liquid line allowable to minimize refrigerant charge.
- 5) Applications shaded in light gray indicate capacity multipliers between 0.90 and 0.96 which are not recommended, but are allowed
- 6) Applications shaded in dark gray are not recommended due to excessive liquid or suction pressure drop.

Performance Data @ AHRI Standard Conditions – Cooling

DESIGNATED TESTED COMBINATION (DTC)							
OUTDOOR UNIT	INDOOR COIL	TOTAL CAPACITY BTU/H [KW]	NET SENSIBLE BTU/H [KW]	NET LATENT BTU/H [KW]	SEER2	EER2	INDOOR CFM [L/S]
RA18AZ24AJVC	RHMVZ2421MEACN	22,400 [6.6]	17,200 [5.0]	5,200 [1.5]	18.0	10.5	825 [389.4]
RA18AZ36AJVC	RHMVZ6021SEACA	34,600 [10.1]	25,800 [7.6]	8,800 [2.6]	18.0	10.5	1,225 [578.1]
RA18AZ48AJVC	RHMVZ6021SEACA	45,000 [13.2]	32,600 [9.6]	12,400 [3.6]	18.0	10.5	1,575 [743.3]
RA18AZ60AJVC	RHMVZ6024SEACN	55,000 [16.1]	40,200 [11.8]	14,800 [4.3]	18.0	10.5	1,650 [778.7]

NOTE: This data includes DTC (Designated Test Combination) ratings and is for reference purposes only. A full listing of official ratings and system match-ups, along with downloadable certificates, can be accessed from the AHRI website: www.ahridirectory.org.

[] Designates Metric Conversions