

**RECOMMENDED TORQUE VALUES**

<b>UPPER SHOCK BOLTS</b>	<b>14Nm</b>
<b>LOWER SHOCK BOLTS</b>	<b>10Nm</b>
<b>V-LINK SEAT TUBE PIVOT</b>	<b>14Nm</b>
<b>V-LINK SEAT STAY PIVOTS</b>	<b>14Nm</b>
<b>MAIN PIVOT</b>	<b>19Nm</b>
<b>HORST LINK PIVOTS</b>	<b>14Nm</b>
<b>HANGER</b>	<b>25Nm</b>
<b>CABLE GUIDES</b>	<b>2Nm</b>

Product Name	Part #	QTY	Description
<b>Trunnion Mount Upper Shock Bolt Kit</b>	VTEA-LKBT-M10x17-R1	2	Kit to replace the top trunnion shock mount bolts & spacers on all Mythique 27 & 29 frames. Includes bolts & spacers for both sides. No bearings included.
	VTEA-FHWS	2	
<b>Lower Mount Shock Bolt Kit</b>	SWS43-34L	1	Kit to replace the bolts & washers of the lower shock mount on all Mythique 27 & 29 frames. No bearings or shock hardware included.
	SWS-48	1	
	SWS-49	1	
	M6x12L-R61F	1	
<b>V-Link Seat Tube Pivot Kit</b>	NTR-LAX R3	2	Kit to replace the bolts, spacers & threaded element of the main pivot on the suspension linkage on all Mythique 27 & 29 frames. No bearings included.
	NTR-FWS R2	2	
	TB-M8-30L	1	
<b>V-Link Seat Stay/ Horst Link Pivot Kit</b>	VTEA-SAX-26L	1	Kit to replace the bolts, washers & spacers of the rear pivots on the suspension linkage (top of seat stays) or rear chainstay pivots on all Mythique 27 & 29 frames. These pivots share the same hardware. Each kit includes hardware for 1 set of pivots (no bearings included). 2 kits required to replace all V-Link Seat Stay & Horst Link pivots.
	ASEE-LWS	2	
	VTEA-LWS-19x15x5	1	
	VTEA-SNT	1	
<b>Main Pivot Kit</b>	VTEA-LBT-83.5	1	Kit to replace the axle, nut & spacers of the main pivot on all Mythique 27 & 29 frames. No bearings included.
	AFDC-CWS	1	
	NTR-BSP R2	1	
	NTR-BWS	2	
<b>Frame Bearing Kit</b>	6901-2RS	4	Kit to replace the frame bearings on all Mythique 27 & 29 frames. No hardware included.
	6902-2RS	2	
	6802V-2RS	8	
<b>Triple Cable Guide Kit</b>	13-143-183-1-991103	1	Kit to replace the triple cable guide & bolt on a Vitus frame. This kit contains 1 cable guide only.
	M5X16L-M11F	1	
<b>Single Cable Guide Kit</b>	611-024C-050BK-0+	1	Kit to replace the single cable guide & bolt on a Vitus frame. This kit contains 1 cable guide only.
	WS-10x5.2x2T-S	1	

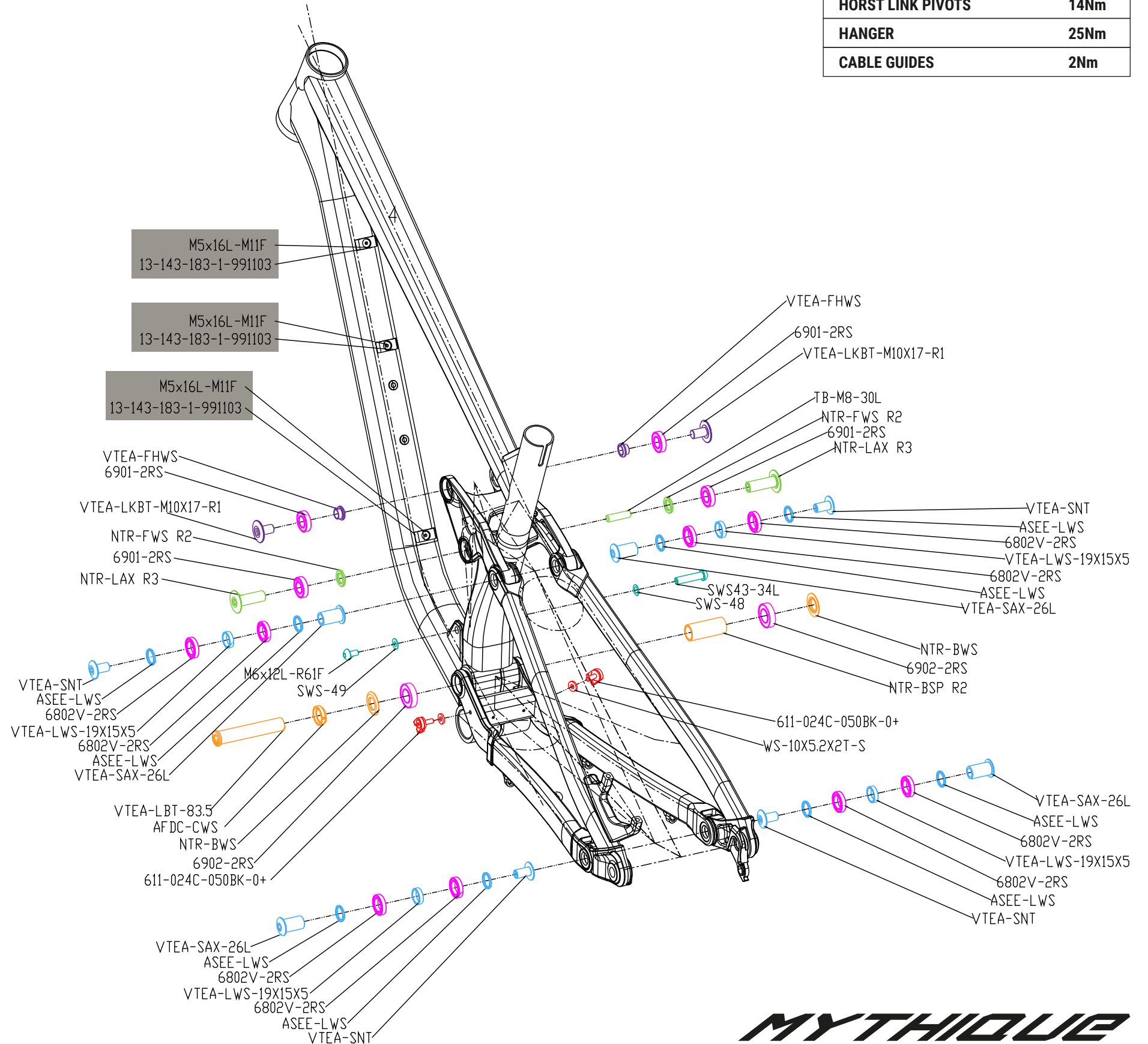

**MYTHIQUE**

**ALL 2023 MODELS ONWARDS**