

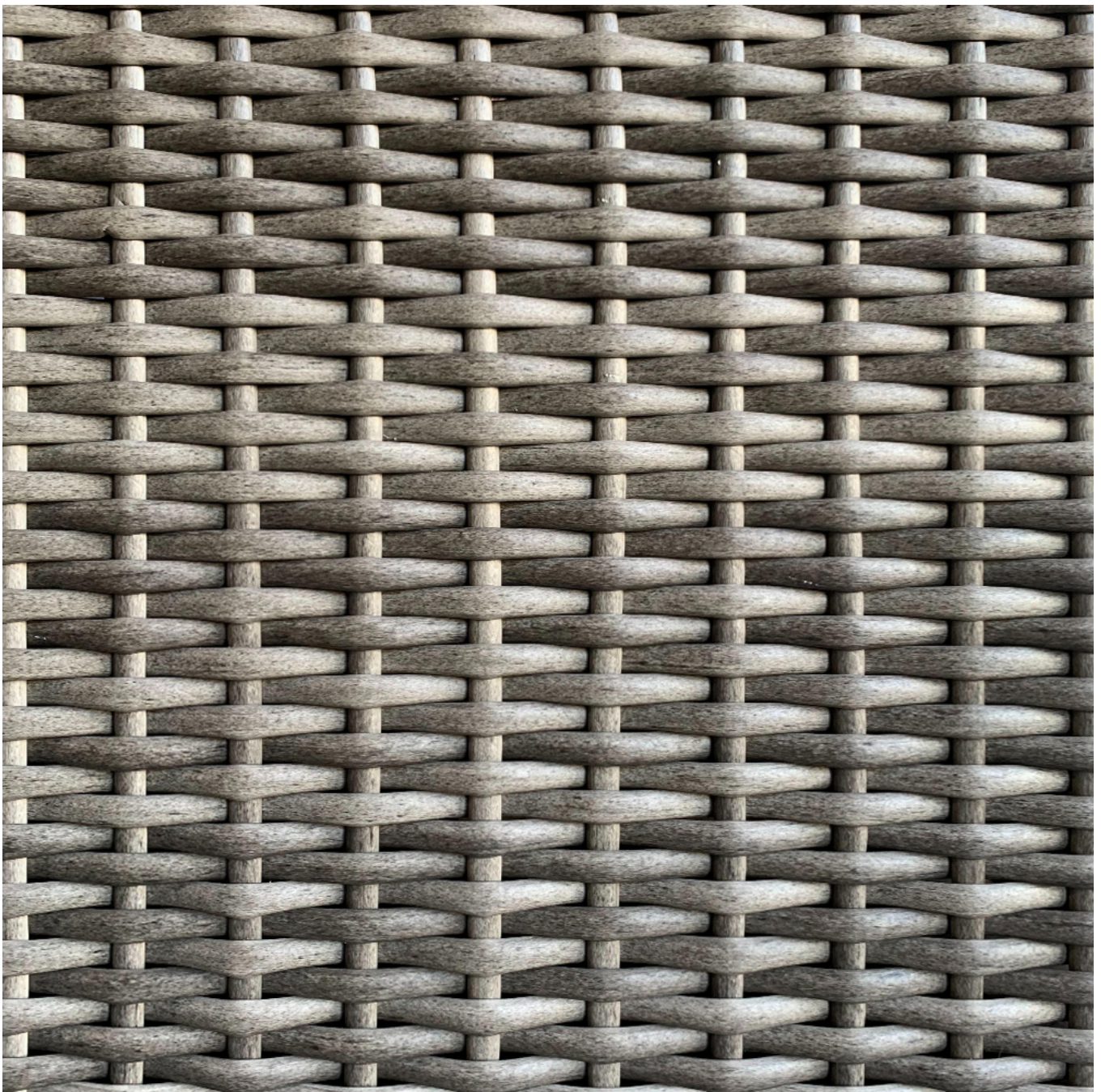

HARMONIA
LIVING

Dune Counter Height Chair - Frame Only HL-DUNE-DW-CHC-NC

Product Images



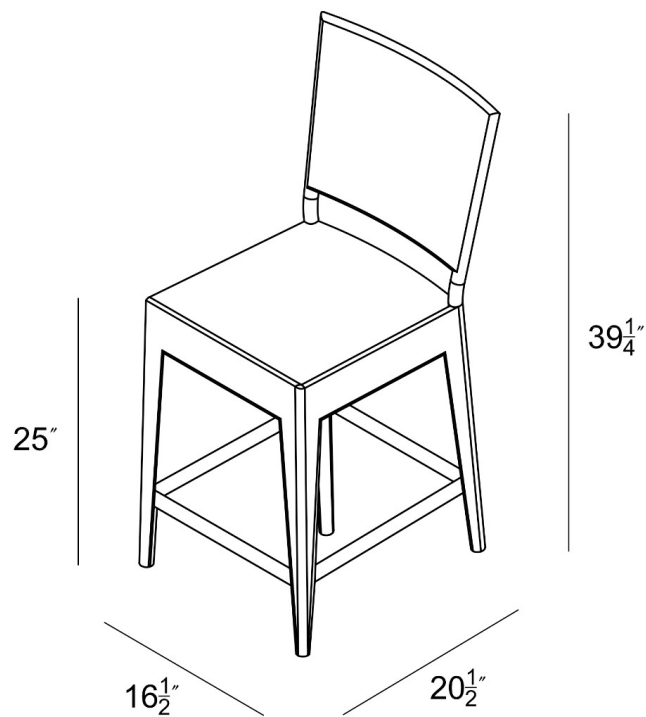

Description

The Dune Collection by Harmonia Living features a clean, simple build that will add modern style to your outdoor dining experience. This piece's neutral colors and beautiful wicker give it a unique visual appeal, while sturdy, all-weather construction ensures lasting performance across the seasons. The wicker is made with durable High-Density Polyethylene (HDPE) and finished in a beautifully textured Driftwood color, which gives it a natural feel. Its sturdy aluminum frame and double reinforced seat are made to endure in any outdoor setting, rain or shine.

Includes

- 1x Dune Counter Height Chair

Dimensions

- Counter Chair: 16.5"W x 20.5"D x 39.25"H (14lbs.)
- Seat Height (No Cushion): 25
- Seat Height (With Cushion): 27
- Back Height (Seat to Top): 12.25

Features

- High-Density Polyethylene (HDPE) Wicker (Driftwood Finish) is all-weather, recyclable and resistant to fading or cracking.
- Thick gauge, powder-coated aluminum frame is lightweight, durable and corrosion resistant.
- Seat frame is double reinforced for lasting durability.
- Includes plastic feet glides to help protect your deck or patio.

- Optional cushions are available in Sunbrella, Outdura and Revolution performance fabrics, which are distinctive, fade resistant and easy to clean. Cushions are made in the USA.
- Cushion cover comes with a zipper for easy removal.
- No assembly required.