

User Manual



AC012K-HU-35

CONTENTS

Safety and Warnings	01
① Package Contents	04
② Product Introduction	05
2.1 Product Details	05
2.2 Specification	06
③ Installation Details	07
3.1 Upstream Wiring	07
3.2 Mounting	08
④ Operation and Configuration	10
4.1 Charging Operation - Plug & Charge	10
4.2 Charging Operation - Use RFID Card	12
4.3 Evchargo APP	13
⑤ Troubleshooting	23
⑥ Maintenance	24
⑦ Warranty	24
⑧ Declaration	26
⑨ Frequently Asked Question	28

Safety and Warnings



WARNING: Important Safety Instructions:

This manual contains important instructions for Models AC012K-HU-35. The following basic precautions should be followed during installation, operation and maintenance. For the general instructions, the types of specific models are not required to be indicated:

- Read all the instructions before installing or using this product.
- The charging should be supervised when used around children. Do not allow children to operate the charge point.
- Do not touch the connector or end terminals with your fingers or any sharp metallic objects or tools.
- Do not use this product if the flexible power cord or EV cable is frayed, has broken insulation, or has any other signs of damage.
- Do not use this product if the enclosure or the EV connector is broken, cracked, open, or shows any other indication of damage. Please save these instructions.



WARNING: Improper connection of the equipment-grounding conductor will result in a risk of electric shock. Please contact a qualified technician if you are confused about whether the product is properly grounded. Do not refit the plug provided with the product – if it does not fit the socket, please contact a qualified technician to have a proper socket installed.

















WARNING: Grounding Instructions:

This product must be grounded. If it occurs malfunction or breaks down, grounding will provide a path of least resistance for electric current to reduce the risk of electric shock. This product is equipped with a cord that has an equipment-grounding conductor and a grounding plug. The plug must be plugged into an appropriate socket that is properly installed and grounded under the local regulations.



WARNING: User Maintenance Instructions:

Turn off the power to the charge point before cleaning. Do not use cleaning solvents to clean any part of the charge point. The enclosure, cable and connector should be cleaned with a clean, dry cloth to remove dust and dirt. Grounded under the local regulations.

-  **WARNING:** Moving, Transporting, and Storage Instructions: Improper movement or storage of the charge point will result in damage to the product.
-  **WARNING:** Turn OFF the circuit breaker at the service panel before performing any electrical work or repair.
-  **WARNING:** The charging should be supervised when used around children. Do not allow children to operate the charger.
-  **WARNING:** Keep the charge point away from explosive or flammable materials, chemicals, vapors and other hazardous objects.
-  **WARNING:** Do not touch the connector or end terminals with your fingers or any sharp metallic objects or tools. Do not put fingers into the socket pin when the unit is powered on.
-  **WARNING:** If the charge point occurs repeated fault, please contact the qualified personnel.
-  **WARNING:** Use or operate charge point:
- It should be in a well-lit area and away from the crowded place to avoid accidental tripping risk.
 - Away from areas of child activity to avoid potential shock risk
-  **WARNING:** Turn off the power supply or unplug the charge connector to achieve electrical isolation.
-  **WARNING:** Do not tamper with or modify this device.
-  **WARNING:** Do not use this device if the charger fails to work correctly in accordance with the operation manual. Contact the qualified technician to repair or contact the supplier for replacement.
-  **WARNING:** Improper installation of the charge point will result in personal injury or product damage.
-  **WARNING:** This charge point installation guide is not a substitute for electrical safety precautions.
-  **WARNING:** Use this charge point within the specified operating parameters, otherwise may result in injury or death.
-  **WARNING:** Install the charge point in a location where the charging cable will not be stepped on, tripped over, damaged or stressed.

 **WARNING:** Do not use the charge point if the flexible power cord or cable is frayed, has broken insulation, or any other signs of damage.

 **WARNING:** Only for use with vehicles that do not require ventilation.

 **WARNING:** To avoid a risk of fire or electric shock, do not use this device with an extension cord.

 **WARNING:** Risk of explosion. This equipment has arcing or sparking parts that should not be exposed to flammable vapors. This equipment should be located at least 460 mm (18 inches) above the floor.

 **CAUTION:** Incorrect installation of the charge point will result in the risk of damage to the battery of vehicle and the charge point itself. These damages will void the warranty for the vehicle and the charge point.

 **CAUTION:** Do not operate the charge point in temperatures beyond its specified operating range.

 **CAUTION:** Risk of electric shock. Do not remove cover or attempt to open the enclosure. No user serviceable parts inside. Refer servicing to qualified service personnel.

 **CAUTION:** Do not use this product if there is any damage to the unit. To reduce the risk of electric shock, connect only to properly grounded outlets.

Alternating current supply symbol:



01/ Package Contents



Mounting Template (*1)



User Manual (*1)

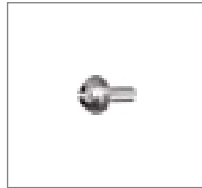

M4*12 Screw (*2)

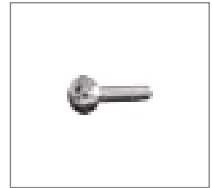

M4*32 Screw (*6)



Connector Holster (*1)



Φ6 Wall Plugs (*6)



RFID card (*2)



M4 Hex Key (*1)

02/ Product Introduction

2.1 Product Details

External Cover

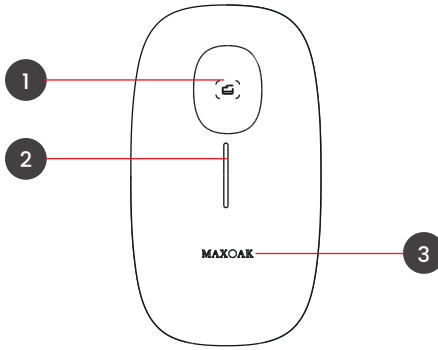

Front View

Base Cover

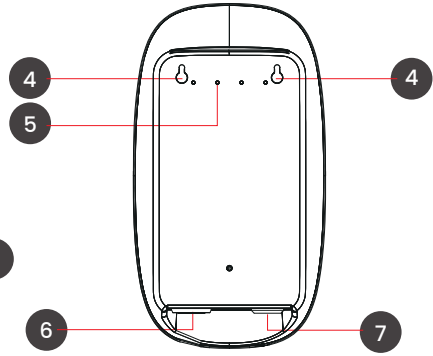

Rear View

① RFID card sensing area

② Indicator strip
Yellow
Red
Green

③ Logo only

④ Mounting holes

⑤ Drain holes

⑥ Outgoing cable hole

⑦ Incoming cable hole

2.2 Specification

Specification		AC012K-HU-35
Input	Power Supply	Single-Phase
	Rated Voltage	240V AC
	Rated Current	50A
	Frequency	60Hz
	Maximum Current	50A
	Input Plug	Hard-wire
Output	Output Power	12kW
	Charging Outlet	Type 1
	Cable Length	≥23ft
Communication	WiFi	Yes
	Bluetooth	Yes
User Interface	Housing Material	Plastic PC
	LED Indicator	RED/YELLOW/GREEN
	Start Mode	Plug & Charge/RFID/APP
Safety	Leakage Current Protection	CCID 20
	Enclosure Rating	NEMA 4
	Electrical Protection	Over current protection, Leakage current protection, Ground protection, Surge protection, Over/Under voltage protection, Over temperature protection
	Certification standard	UL 2594, UL 2231-1 & -2
Environment	Installation	Wall-mount
	Working Temperature	-30℃~+50℃
	Working Humidity	5%-95%
	Working Altitude	<2000m
Package	Product Dimension	344*192*101mm(H*W*D)

03/ Installation Details

Upstream Wiring Charging stations are considered continuous load devices (EVs draw maximum load for long durations); therefore, electrical branch circuits must be sized at 125% of the load for North American installations, in accordance with National Electric Code (NEC) requirements. (For other regions, refer to local code.) This means that for a maximum 50 A load at 240 V output to an electric vehicle, 65 or 70 A breakers are required.

3.1 Upstream Wiring

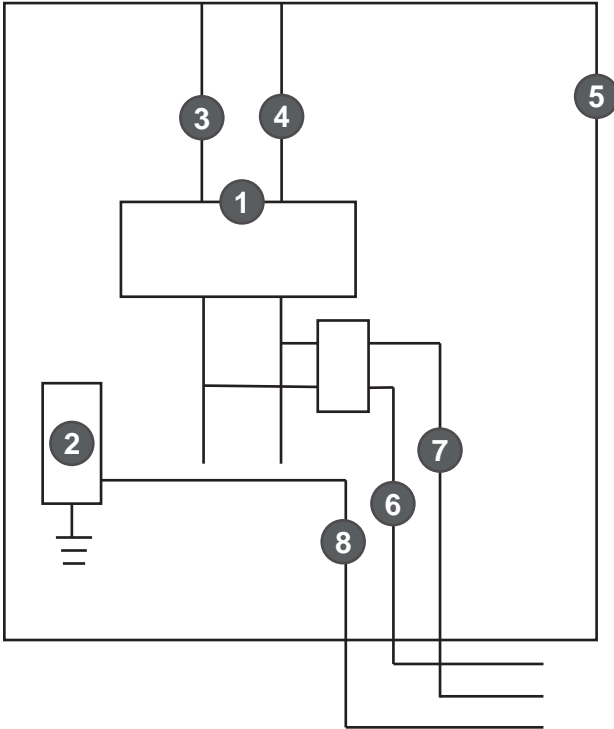

- | | | | |
|-------------------------------|-----------|-------|-------|
| 1. Main Breaker | 2. PE Bus | 3. L1 | 4. L2 |
| 5. Local Service or Sub Panel | 6. L1 | 7. L2 | 8. PE |

3.2 Mounting

1. Installation Notice

- All applicable local, regional, and national regulations must be applied when installing, repairing and maintaining this device.
- The charger can be installed on wood, stone, cement or metal walls, but make sure it can be fixed and will not fall easily.
- This device shall be mounted at a sufficient height from ground such that the height of the storage means for the coupling device is located between 450 mm (18 inches) and 1.2 m (4 feet) from ground.
- This device is installed permanently, if need to change the position, please use required tools.

2. Checks before starting the Installation Process

- Ensure the charger's location allows good operational access for normal use and repair & maintenance.
- The AC input components within the premise's power supply are correctly fitted with required protection items prior to installation of the charger.

3. Installation Procedure

- 1) Based on the holes of the wall-side bracket, drill 3 x $\Phi 6 * 35$ mm holes on the wall, and insert the expansion pipe.

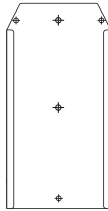

- 2) Lock the wall-side bracket onto the wall by 3 x M4*32mm self-tapping screws.

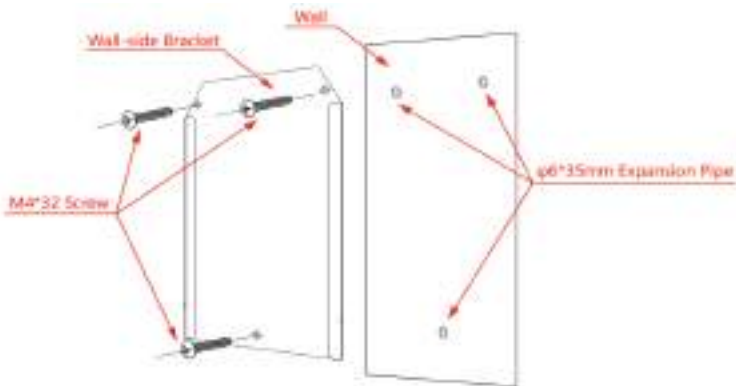

3) Hang the EV charger on the wall-side bracket, let the top of wall-side bracket inset into charger-side bracket, and two sides of charger-side bracket insert into wall-side bracket.



4) Lock the 2 x M4*12mm screws on two sides of the bracket component.



04/ Operation and Configuration

4.1 Charging Operation - Plug & Charge

Standby

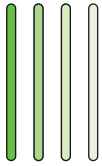

A green indicator flashing slowly for 1s at 3-sec intervals indicates the charger is ready to use.

Plug in



Plug the charging connector into your EV's charging socket.

A green indicator flashing for 200ms at 1-sec intervals indicates the charging connector is plugged in.

Charging



A green indicator breathing at 1-sec intervals indicates the charging is in progress.

Tips: The charger will undergo self-testing after power on, it takes about 30s.

Fully charged



Solid green light indicates the EV is fully charged.

Unplug



Unplug the charging connector. Return to standby mode after the charging has finished.

4.2 Charging Operation – Use RFID Card

Plug in

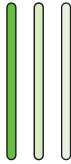

Plug the charging connector into your EV's charging socket.

A green indicator flashing for 200ms at 1-sec intervals indicates the charging connector is plugged in.

Use RFID Card



Put the RFID card on the reading area to start or stop charging.

A yellow indicator flashing at 100-ms intervals indicates the RFID card is successfully read.

4.3 Evchargeo APP

Evchargeo is your charger's companion app. After connecting your charger to Evchargeo, and select the scenario for home, you can use the app to intelligently control your charger and enjoy the charging service.

Use your mobile device to scan the QR code below to download and install Evchargeo app.



Evchargeo Download
(Apple Store & Google Play)

4.3.1 Account Creation and Login

To create an account, you can follow the steps below:

Step 1: Open Evchargeo App, and click on Sign Up.

Step 2: Enter your Email and select the country then click on Continue.

Step 3: Enter the verification code you received (you will be received an verification code in your email).

Step 4: Set password and accept the Privacy policy and User terms then click on Sign up.

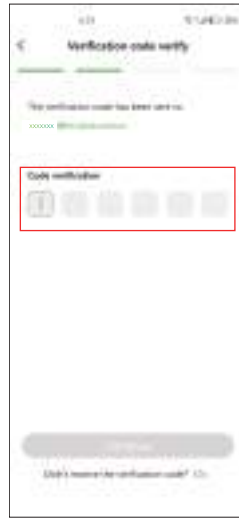
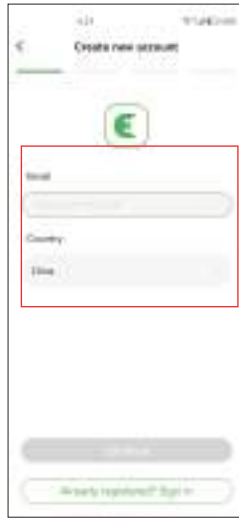

4.3.2 Select Scenario

Based on your role, Evcharge offers two scenarios for you to use the charging service: if you have your own home charge point, click on the Charge Point icon, as shown below:



4.3.2.1 For the scenario you have your own charge point

Before you initiate a charging session using Evcharge, you are required to make some configurations first, please follow the following steps to complete the configuration:

Step 1: Enable permissions

You will be presented with a page where you can allow Bluetooth, Wi-Fi, and location permissions, as shown on Figure below.

Step 2: Select the brand of charger point

Select your charge point's brand, as shown in Figure 6 - Select brand.

Step 3: Bind the charge point

There are three ways to bind the charge point:

Scan the QR code: Scan the QR code on the charge point.

Add a charge point manually: Enter the ID of the charge point.

Check for nearby charger point: Check the available charge points nearby, and choose the ID of the charge point you want to bind to.



Permission

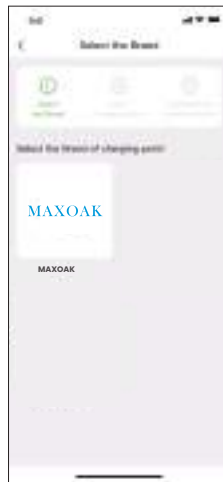

Select brand



Add a charge point

Step 4: Select operator

Select the Operator from the list; the operator is the one from whom you purchased your charge point.

Step 5: Select the communication mode

To establish a communication for your charge point, there are three communication modes for you to select, online mode enables you to remotely control your charge point, while the Bluetooth mode and plug & charge mode are for local operation.

Online mode

In this mode, you can remotely control your charge point, but you need to configure the network for your charge point.

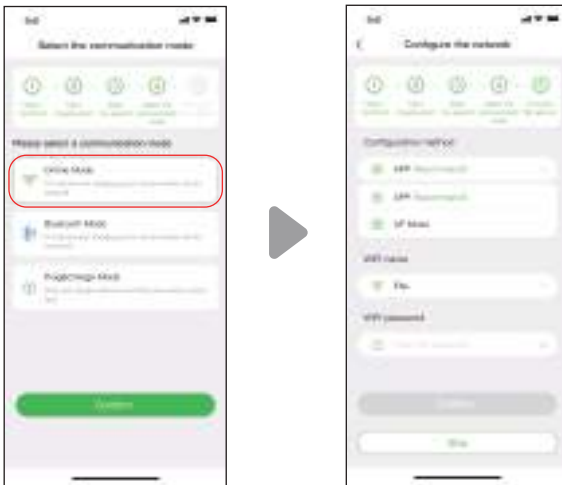

Select App (recommend) in the configuration method, and the networking method will be Wi-Fi by default.

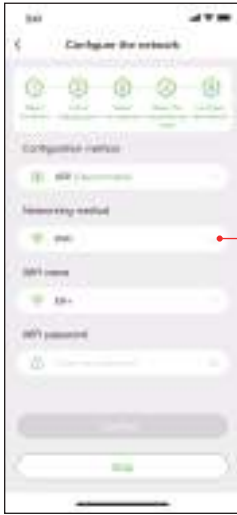

The available networking method may vary depending on your charge point. You can select Wi-Fi for networking in the drop-down options.

Bluetooth mode

To connect your charge point to your mobile device via Bluetooth, and you can control your charge point by the Bluetooth communication.

Plug & Charge mode

Select this mode, and you can get your car charged by simply plugging the connector into your car.

4.3.3 Charging Process

There are three ways for you to charge your car:

Charging via Network

Charging Via a RFID card

Plug & Charge.

4.3.1 Charging via network

When you select Charging via network, please refer to the above Online Mode, and make sure you have completed the network configuration.

You can directly start the charging session, or you also can customize the charging by setting the maximum current and the charging schedule when you reach the page as shown below:

Here is the signal strength of the Wi-Fi.

Where Wi-Fi will be used the chargepoint must be in range of a wireless access point and the signal must be strong and stable at the charge point. Users may need to consider an external antenna and/or booster to their Wi-Fi system to reach remote charge points.

Set the current at a gradient of 1A.

Set the time period you want to charge your car, then the charging session will start and end at the set time.



If the signal strength of Wi-Fi is poor, you will be prompted with the tip to change to Bluetooth mode.



The purpose for setting the maximum charging current is to ensure the household electricity consumption, for example, if the current threshold for tripping in your home is 50A and the household appliances have consumed 30A, you must ensure that the output current for the charge point falls within 20A to avoid tripping.

Sometimes the status of the charge point and its network states may not be up to date, you need to refresh the status by slightly pulling down the page.

Pull down hard slightly to get the charge point state refreshed.



Pull down hard and you will enter the configuration as shown below

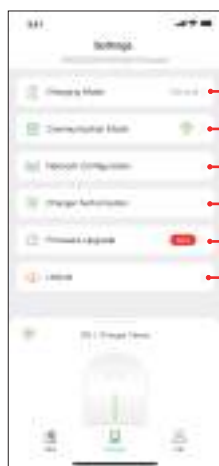

- You can choose the charging modes.
- You can reselect the communication mode. There will be a delay of about 10s when switching communication mode.
- You can change a Wi-Fi hotspot or Ethernet or 4G to connect.
- You can authorize your charge point to be used by others, provided they have registered the app.
- In order to provide you with better service, our firmware will be updated from time to time, so please update the firmware to the latest version if prompted.
- The "unbind" operation will not delete your account, but it will delete the information and settings related to this charge point.



The Charging Mode and the networking method in Network Configuration may vary depending on the functional configuration of your charge point.

Note:

Clicking on the **Start** button, and the charging session will begin after the charge point responds successfully. As shown below, you can view the charging information, including charging speed, charging time, voltage, current and power on the App, and you also can click on the **Stop charging** button to terminate the charging session.

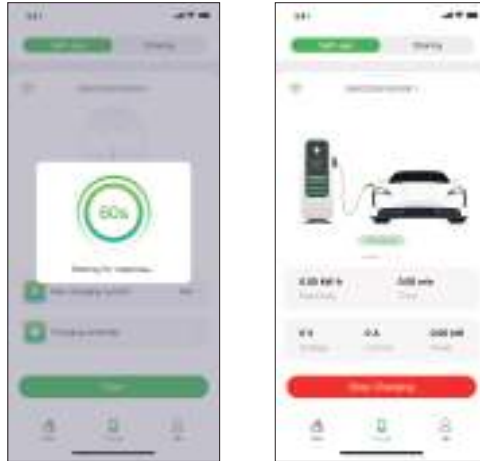

4.3.2 Charging via a RFID card

Before you charge your car, you need to add a RFID card first.

Click **Me** > **Card Management** > **Add a card** to add a RFID card for your charge point.

After plugging the connector into the car, you can use the card to start and end the charging session by touching the sensor area of the charge point.

4.3.3 Plug & Charge

You need to switch the communication mode to plug & charge by pulling down the charging page hard, then just plug the connector into the car and the charging session begins.

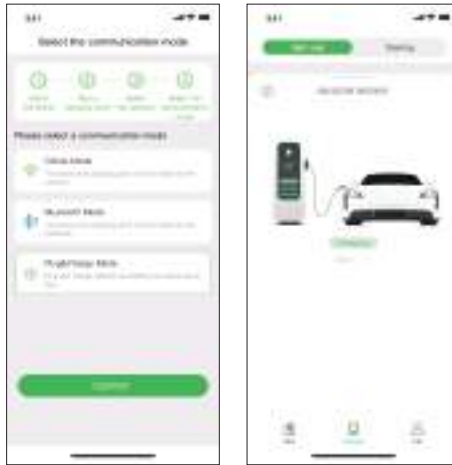

4.3.4 Authorize your charge point to be used by others

By way of authorization, Evcharge provides two ways for you and your family and friends to share charge points: Authorize by binding email and authorize by RFID card.

4.3.4.1 Authorize by binding email

Before using this function, please make sure that the authorized users have downloaded and registered Evcharge. Pull down hard on the charging page to enter the setting page, select charge point authorization to add authorized users. You can only authorize a maximum of 8 users by email.

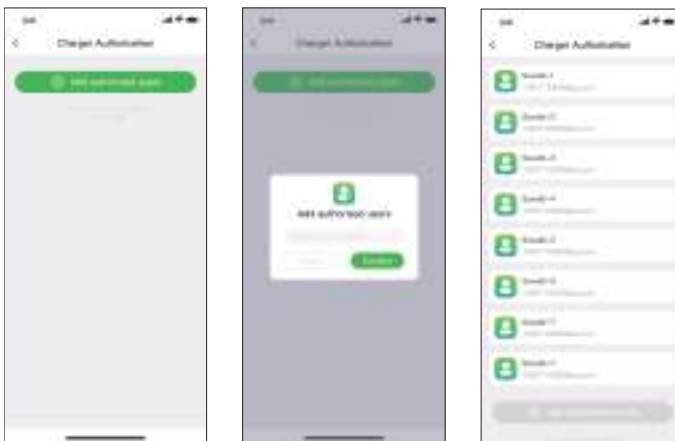

4.3.4.2 Authorize by RFID card

Before using this function, please make sure that the authorized users have downloaded and registered Evcharge, and have added the RFID card, you need get the data of the authorized user synchronized to your charge point, and he/she can share the charge point with you.



This product does not support 4G/Ethernet communication; this product does not support load balancing mode.

05/ Troubleshooting

Fault	Indicator Status	Solution
Leakage current fault	Red indicator keeps on	Charging stopped, please notify the after-sales service to solve the fault.
CP fault	Red indicator keeps on	Charging stopped, please notify the after-sales service to solve the fault.
Overcurrent	Red indicator keeps on	Charging stopped, please try again 10 minutes later.
Input terminal overtemperature	Red indicator keeps on	Charging stopped, please try again 10 minutes later.
Relay over temperature	Red indicator keeps on	Charging stopped, please try again 10 minutes later.
Under voltage	Red indicator keeps on	Grid abnormal, charging stopped, please try again 10 minutes later.
Over voltage	Red indicator keeps on	Grid abnormal, charging stopped, please try again 10 minutes later.



If the fault persists, please contact customer service:
service@maxoak.net

06/ Maintenance

No.	Item	Operating process
1	Keep the charging station clean.	Use a cloth to clean the charger surface. If there is any damage or dirt on the vehicle connector, charging cable, or vehicle connector holder, please contact customer service immediately.
2	Keep the charging station intact.	Do not hit or press hard on the case. If the case is damaged, please contact customer service.
3	Avoid letting moisture or water enter the charging station.	If there is water or moisture inside the charging station, you must immediately switch off the electricity supply to avoid immediate danger. Please notify your maintenance professional before continuing to use the station.
4	Avoid charging station rusted.	Keep the charging station away from dangerous substances such as flammable gases and corrosive materials.

07/ Warranty

Period: Unless otherwise stated by local laws, we will provide a limited warranty of up to 2 years starting from the date of purchase.

Scope: The Charging station and charging connector.

The limited warranty does not cover the following :

1. Normal wear and tear.
2. Damage or failure caused by unauthorized upgrades conducted by a
3. customer.

Damage or failure caused by external factors such as fire, flood, abnormal voltage, other natural disasters, and secondary disasters.

4. Damage or failure caused by improper handling of the charging station, such as impact from a fall and careless transportation after purchase.
5. Damage or failure caused by a customer not following the user manual.
6. Damage or failure caused by non-equipment factors like human error by a non-authorized individual carrying out maintenance. Unauthorized repairs will render the limited warranty void. Damage or failure caused by external factors such as power grid malfunctions.

Limitation of liability:

We have compiled this document to the best of its knowledge but cannot guarantee that all information provided is error-free, nor will it accept liability in this respect.

To the maximum extent permissible under local applicable law, we hereby disclaims any and all indirect, incidental, special and consequential damages arising out of or relating to the AC Charger, including, but not limited to, loss of time, loss of income, loss of use, loss of personal or commercial property, inconvenience or aggravation, emotional distress or harm, commercial loss (including but not limited to lost profits or earnings), incidental charges such as telephone calls, facsimile transmissions, and mailing expenses. To the maximum extent permissible under local applicable law, we will not be liable for any direct damages in an amount that exceeds the market value of the AC Charger at the time of the claim.

The above limitations and exclusion will apply whether or not the customer's claim is in contract, tort (including negligence and gross negligence), breach of warranty or condition, misrepresentation (whether negligent for otherwise) or otherwise at law or in equity, even if we has been advised of the possibility of such damages or such damages are reasonably foreseeable.

Nothing in this manual shall exclude, or in any way limit, our liability for death or personal injury solely and directly caused by their negligence, or that of its employees, agents, or sub-contractors (as applicable), fraud, or fraudulent misrepresentation, or any other liability to the extent the same is proven in a court of competent jurisdiction in a final non-appealable judgment and may not be excluded or limited as a matter of local law.

08/ Declaration

This device complies with Part 15 of the FCC Rules. Operation is subject to the following two conditions: (1) this device may not cause harmful interference, and (2) this device must accept any interference received, including interference that may cause undesired operation.

Changes or modifications to this unit not expressly approved by the party responsible for compliance could void the user's authority to operate the equipment.

NOTE: This equipment has been tested and found to comply with the limits for a Class B digital device, pursuant to Part 15 of the FCC Rules. These limits are designed to provide reasonable protection against harmful interference in a residential installation. This equipment generates, uses and can radiate radio frequency energy and, if not installed and used in accordance with the instructions, may cause harmful interference to radio communications. However, there is no guarantee that interference will not occur in a particular installation. If this equipment does cause harmful interference to radio or television reception, which can be determined by turning the equipment off and on, the user is encouraged to try to correct the interference by one or more of the following measures:

- Reorient or relocate the receiving antenna.
- Increase the separation between the equipment and receiver.
- Connect the equipment into an outlet on a circuit different from that to which the receiver is connected.
- Consult the dealer or an experienced radio/TV technician for help.

This device and its antenna(s) must not be co-located or operation in conjunction with any other antenna or transmitter.

Radiation Exposure Statement

To maintain compliance with FCC's RF Exposure guidelines, This equipment should be installed and operated with minimum distance of 20cm from your body.

IC Statement

This device complies with Canada Industry licence-exempt RSS standard(s). Operation is subject to the following two conditions:

- (1) this device may not cause interference; and
- (2) this device must accept any interference. Including interference that may cause undesired operation of the device.

Avis d'Industrie Canada

Le présent appareil est conforme aux CNR d'industrie Canada applicables aux appareils radio exempts de licence. L'exploitation est autorisée aux deux conditions suivantes:

- 1) l'appareil ne doit pas produire de brouillage; et
- 2) l'utilisateur de l'appareil doit accepter le brouillage radioélectrique subi même si le brouillage est susceptible d'entraîner un mauvais fonctionnement de l'appareil.

CAN ICES-3 (B) / CAN NMB-3 (B)

Radiation Exposure Statement:

This equipment complies with IC radiation exposure limits set forth for an uncontrolled environment. This equipment should be installed and operated with minimum distance 20cm between the radiator & your body.

Déclaration d'exposition aux radiations:

Cet équipement est conforme aux limites d'exposition aux rayonnements IC établies pour un environnement non contrôlé. Cet équipement doit être installé et utilisé avec un minimum de 20 cm de distance entre la source de rayonnement et votre corps.

09/ Frequently Asked Question (FAQ)

Question 1:

Failed to scan the charger point's QR code

Answer 1:

- 1) Please ensure that Bluetooth permission has been granted in the app and that Bluetooth is enabled on the mobile phone.
- 2) Please ensure that the charger's Bluetooth is turned on.

Question 2:

Failed to configure the Network or the charge point is off-line.

Answer 2:

- 1) Please make sure the WiFi configured for the charge point is 2.4G channel.
- 2) Please make sure the WiFi name and password configured for the charge point are correct.
- 3) Please make sure that the distance between Wi-Fi hotspot and charge point is not very far, and no obstacles to interfere with the signal.