

**oliso<sup>®</sup>**

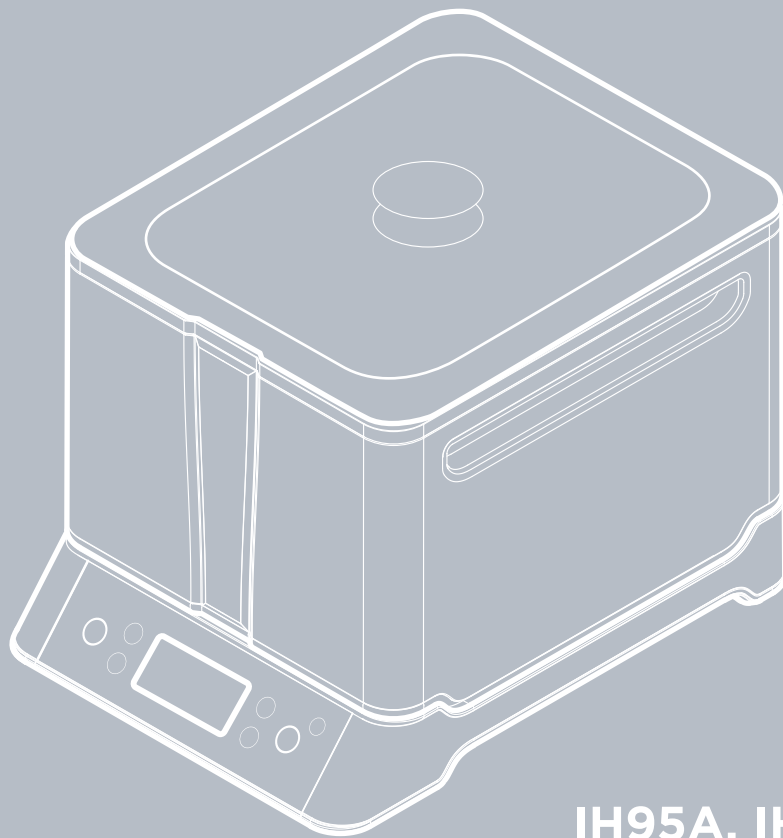

**USER MANUAL  
SAVE THESE INSTRUCTIONS**

**IH95A, IH75A  
ST95A, ST75A**

## Contents:

Important Safeguards

Introducing the Smart Hub™

How Does Induction Work?

Touch Control Panel

LCD Viewing Display Contents for Induction Cooking

Simple Steps to Induction Cooking

Introducing the Sous Vide Smart Top™

Using the Sous Vide Smart Top™

Using the Spacer Plate and Rack

LCD Viewing Display Contents for Sous Vide Cooking

Simple Steps to Sous Vide Cooking

Technical Information

Quick Tips

Care and Maintenance

Troubleshooting

Troubleshooting Error Codes

Warranty

## Thank you!

Thank you for purchasing the Oliso® Smart Hub™. You are just a few steps away from a whole new way of enjoying food.

For more information visit

**[www.oliso.com](http://www.oliso.com)**

## Register your product online:

[www.oliso.com/support/registration](http://www.oliso.com/support/registration)

## Questions?

Contact Oliso Customer Service

Call: 1.800.481.7978

Office Hours: Mon-Fri 8:30am - 4:30pm PST

Email: [customerservice@oliso.com](mailto:customerservice@oliso.com)

# IMPORTANT SAFEGUARDS

When using your Smart Hub™, basic safety precautions should always be followed, including the following:

Read all instructions before using this product.

1. Use flat bottomed pans with a bottom in diameter of at least 9cm, and no greater than 24cm. The pan must be large enough for the safety sensor to activate the heating element. The cooktop will not start if a very small steel or iron utensil (less than the minimum size across the bottom) is placed on the cooking surface when the unit is turned on—items such as steel spatulas, cooking spoons, knives, and other small utensils. The pan detection sensors will not allow the affected Cooking Element to operate without a pan present.
2. Do not touch hot surfaces. Use handles or knobs. Metallic objects such as knives, forks, spoons and lids should not be placed on the hotplate since they can get hot.
3. If the surface is cracked, switch off the appliance to avoid the possibility of electric shock.
4. Cookware handles should be turned inward and should not extend over adjacent cooking elements to reduce the risk of burns, ignition of flammable materials and spillage due to unintentional contact with the utensil. Wear protective gloves or mitts when handling a pan handle as it may be hot and burn skin.
5. Always check to see if a magnet will attract to your own cookware before attempting to use them on the Smart Hub™.
6. Be aware that induction cooktops heat much more rapidly than conventional methods.
7. Never leave food on the cooking elements unattended. Boil overs cause smoking and greasy spillovers that may ignite, or a pan that has boiled dry may melt or become damaged.
8. Protective liners: Do not use aluminum foil to line any part of the cooktop. Any use of aluminum foil could result in the risk of electric shock, fire or short circuit.
9. Keep your cookware centered onto the induction cook top at all times.
10. Do not move the Smart Hub™ during cooking or with hot cookware on top of it. Do not place any metal objects on the Smart Hub™ (other than the cookware you intend to cook in).
11. Do not heat up any unopened cans of food on the Smart Hub™. A heated can of food could explode. Only cook or heat food in induction compatible cookware.
12. Although the surface of the Smart Hub™ remains cool to the touch because heat is transferred directly to the pot or pan, please note that the residual heat from the cookware will eventually warm up the glass cooking surface, especially the area directly underneath the pot or pan. Be careful when handling the smart top after use and let it cool down before storing.
13. Persons with a pacemaker or similar medical device should exercise caution using or standing near an induction unit while it is in operation, as the electromagnetic field may affect the working of the pacemaker or similar medical device. We advise consulting your doctor or the pacemaker or similar medical device

## SAVE THESE INSTRUCTIONS

# IMPORTANT SAFEGUARDS

When using your Smart Hub™, basic safety precautions should always be followed, including the following:

Read all instructions before using this product.

manufacturer about your particular situation.

14. Do not place any magnetized objects like credit cards, cassettes etc. on the glass surface while the Smart Hub™ is in operation. The magnetic properties of the unit can damage these items.

15. In order to avoid overheating, do not place any aluminum foil or metal plates on the cooking surface.

16. Attention: Do not insert any objects like wires or tools into the ventilation slots. This may cause electric shock.

17. Never use the Smart Hub™ when it is not functioning properly, shows signs of damage or if it has been dropped.

18. Do not submerge the Smart Hub™ in water or other liquids and do not wash it in the dishwasher.

19. Before heating, fill the water bath with water to the fill line at minimum, and do not allow water to rise above the max line. Once you fill the water bath with water, you may test how high the water level will rise by placing the vacuum sealed food contents you plan to cook with into the water bath.

20. Use the appliance only for its intended purpose.

21. To protect against the risk of electric shock, do not immerse the Smart Hub™, water bath, plug or power cord in water or other liquids.

22. Do not use outdoors.

23. This appliance can be used by children aged from 8 years and above and persons with reduced physical, sensory or mental capabilities or lack of experience and knowledge if they have been given supervision or instruction concerning use of the appliance in a safe way and understand the hazards involved.

24. Children shall not play with the appliance.

25. Cleaning and user maintenance shall not be made by children unless they are older than 8 and supervised.

26. Keep the appliance and its cord out of reach of children less than 8 years.

27. Always unplug the appliance when not in use and before cleaning. Allow the appliance to cool before putting on or taking off parts to clean.

28. Do not operate the appliance on an inclined, unstable, or metal surface.

29. Do not move or cover the appliance whilst in operation.

30. Use the appliance well away from walls and curtains, and do not use in confined spaces.

31. Do not touch any metal surfaces of the appliance, while it is in use as they could be hot.

32. Use handles and oven mitts to move the appliance, the cooking pan and the lid when hot.

33. Do not operate the appliance without liquid in the cooking pan.

## SAVE THESE INSTRUCTIONS

# IMPORTANT SAFEGUARDS

When using your Smart Hub™, basic safety precautions should always be followed, including the following:

Read all instructions before using this product.

34. Be careful when lifting and remove lid of water bath after cooking. Always tilt the lid away from you as steam is hot and can result in serious burns. Never place face over the water bath.
35. Do not use the water bath for food storage or place in the freezer.
36. Extreme caution must be used when moving an appliance containing hot oil or other hot liquids.
37. Always use the appliance from a power outlet of the voltage (A.C. only) marked on the appliance.
38. This appliance is not intended for use by persons (including children) with reduced physical, sensory or mental capabilities, or lack of experience and knowledge, unless they have been given supervision or instruction concerning use of the appliance by a person responsible for their safety.
39. The temperature of accessible surfaces may be high when the appliance is operating.
40. Do not use the appliance for any purpose other than its intended use.
41. Do not place the appliance on or near a hot gas flame, electric element or on a heated oven.
42. Do not place on top of any other appliance such as a refrigerator.
43. Do not cook on a broken cook-top. If the cook-top should break, cleaning solutions and spillovers may penetrate the broken cook-top and create a risk of electric shock.
44. Clean the cook-top with caution. If a wet sponge or cloth is used to wipe spills on a hot cooking area, be careful to avoid steam burn. Some cleaners can produce noxious fumes if applied to a hot surface.
45. This appliance is not intended to be operated by means of an external timer or separate remote control system.
46. This is a high wattage appliance — 1500W at 120V, 60Hz. To avoid a circuit overload, do not operate another high wattage appliance such as a vacuum sealer or microwave on the same circuit.
47. Never direct fill the appliance from a water tap while the appliance is plugged into a power source.
48. Avoid placing any objects on or near the keypads in order to prevent accidental activation of the cooktop controls.
49. Clean the appliance regularly to keep all parts free of grease that could catch fire.
50. Never attempt to disassemble and repair the appliance yourself!
51. This appliance is intended to be used in household and similar applications such as:
  - Staff kitchen areas in shops, offices and other working environments
  - Farm houses
  - By clients in hotels, motels and other residential type environments
  - Bed and breakfast type environments

## SAVE THESE INSTRUCTIONS

# IMPORTANT SAFEGUARDS

When using your Smart Hub™, basic safety precautions should always be followed, including the following:

Read all instructions before using this product.

52. The use of accessory attachments not recommended by the appliance manufacturer may cause injuries.

## **Power Cord Instructions:**

1. This appliance has a polarized plug (one blade is wider than the other). To reduce the risk of electric shock, this plug is intended to fit into a polarized outlet only one way. If the plug does not fit fully into the outlet, reverse the plug. If it still does not fit, contact a qualified electrician. Do not attempt to modify the plug in any way.
2. Never tug cord from the outlet. Grasp plug and pull to disconnect. Do not unplug the Smart Hub™ when in use. Only unplug the appliance during standby mode.
3. Do not use the appliance with an extension cord unless this cord has been checked and tested by a qualified technician or service person.
4. Do not let the power cord of the appliance hang over the edge of a table or bench top or touch any hot surface. Keep appliance at a distance of at least 6 inches from the edge of counter top.
5. Do not operate the appliance with a damaged cord or plug after the appliance has been damaged in any manner. If damage is suspected, please contact customer service at Oliso®.
6. A short power-supply cord is used to reduce the risk of entanglement or tripping over a long cord.
7. Longer extension cords may be used if care is exercised in their use.
8. To disconnect, turn off the induction cooktop, then remove plug from the outlet.
9. If an extension cord is used:
  - a. The marked electrical rating of the extension cord should be at least as great as the electrical rating of the appliance.
  - b. The cord should be arranged so that it will not drape over the countertop or tabletop where it can be pulled on by children or tripped over unintentionally.

## **SAVE THESE INSTRUCTIONS**

## Introducing the Oliso® Induction Smart Hub™

The Oliso® Smart Hub™ teams with the sous vide smart top to rapidly reach a precise temperature, and continue to maintain that temperature with minimal energy consumption. Additionally, the sous vide smart top may be removed, providing you with a cooktop for searing and other use.

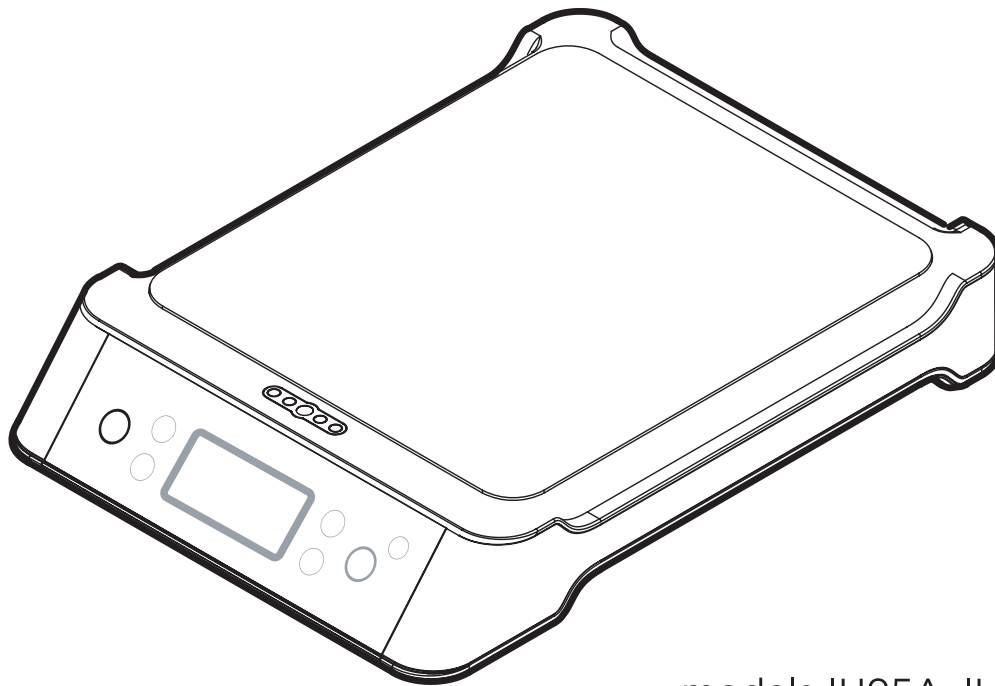

models IH95A, IH75A

## How Does Induction Work?

Induction technology uses magnetic coils to directly heat your pots and pans. When active, the coils create a magnetic field that will heat the metal of the cooking vessel itself.

## What are the Benefits of Cooking With an Induction Cooktop?

- **Fast:** Digital controls make this technology fast and precise. Raising temperature control is immediate, and predictable. Because of this, the Sous Vide+ will reach the set temperature in half the time it takes competing units, and maintain that temperature precisely.
- **Energy Efficient:** Because energy is focused on heating the pan itself, there is little wasted energy.
- **Even heat distribution:** The extra thick conductive layer on the underside of the pan helps to evenly disperse the rapid heat. As heat is produced on the bottom of the water bath, natural convection currents cause the hot water to rise and create an even bath temperature.
- **Easy cleanup:** Smooth glass surfaces make spills easy to clean.

## What Type of Cookware Can I Use on Induction?

The simple step to determine if your pan is suitable for induction cooking is to use a common refrigerator magnet, and see if it sticks to the bottom of your pan. Induction technology uses magnetic principles to detect and heat the pan, so suitable cookware must be ferrous (iron based or magnetic).

### Compatible:

- Stainless steel with a magnetic base
- Cast Iron
- enameled iron and steel

### Non-induction compatible:

- Copper
- Glass
- Aluminum
- Ceramic



look for the induction ready symbol on your cookware



\*If a magnet will stick to your cookware, it should be compatible!

\*Additional note: Bottom of cookware must be flat and be at least 9cm in diameter to be properly detected. Warped cookware will not heat evenly.



# Touch Control Panel

- 1) POWER - on/off button
- 2) TEMP - touch to select and change the temperature settings. (only necessary in sous vide operation)
- 3) TIME - touch to select and change the timer settings.
- 4) UP/DOWN - touch to increase or decrease temperature or time settings. Touch and hold to scroll faster.
- 5) START - When you first touch the start button, the unit will begin heating. You may touch the START button again to activate the timer function. (timer will only activate in sous vide mode when the set temperature has been reached)
- 6) LOCK - touch and hold to activate and deactivate the safety lock features. This is to prevent accidental temperature, time, or power adjustments while cooking.

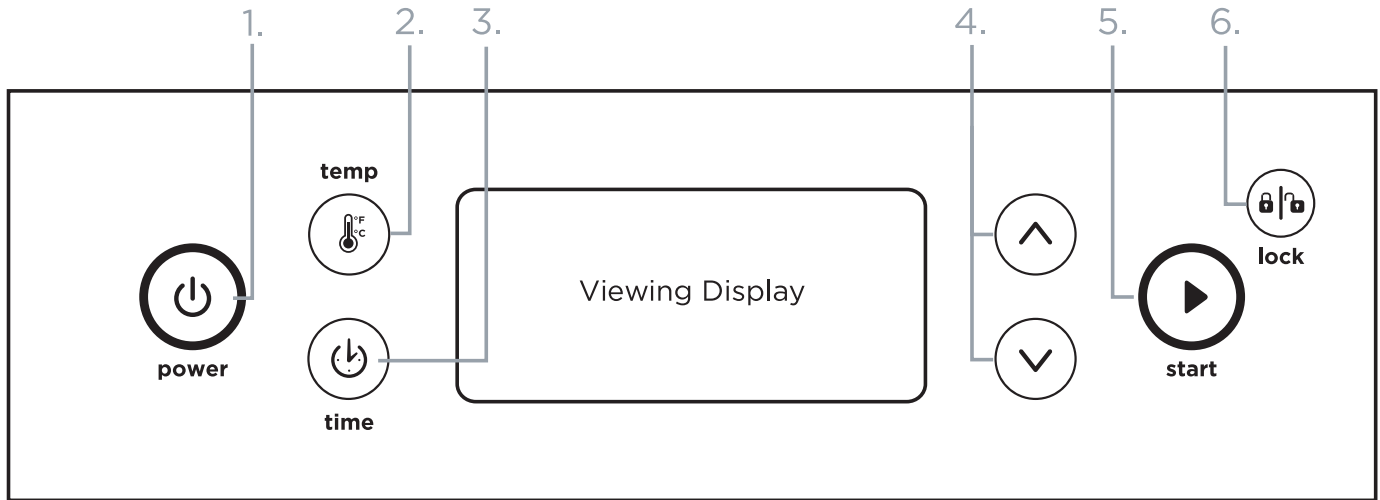

## LCD Viewing Display Contents for Induction Cooking

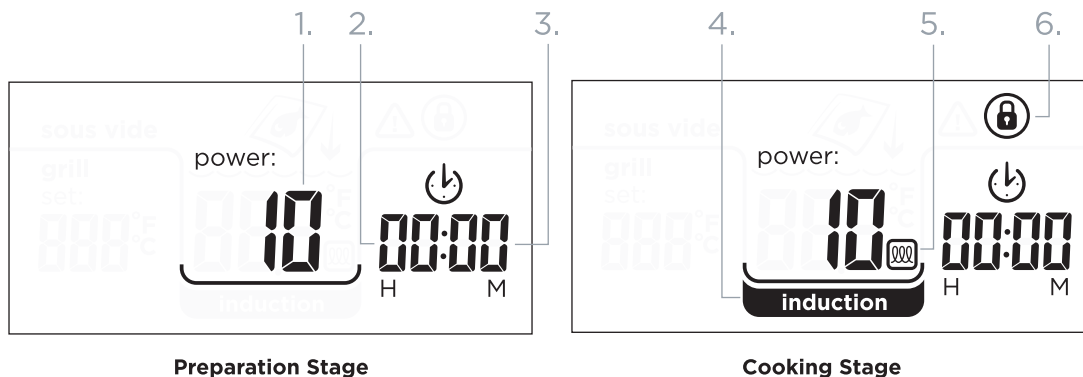

**Induction Mode:** (cooking with an induction-ready pan)

1. **POWER LEVEL** - Displays the current power level setting, ranging from 0 to 10 (10 being the most power). If this icon is flashing, press the START button to confirm setting and start heating the pan.
2. **HOUR** - Displays the hour variable of the timer. Touch the TIMER button again to change the MIN value.
3. **MIN** - Displays the minute value. Touch the START button to activate the timer. When using the sous vide smart top, timer will only activate when the set temperature has been reached.
4. **INDUCTION** - This icon is displayed once the START button has been activated, and the unit is heating. This icon will flash if no pan is detected while trying to heat.
5. **COIL** - This icon represents the induction heating coil. This icon is inactive while the pan is removed.
6. **LOCK** - This icon is visible when the child lock feature is active. This feature prevents accidental setting changes.

## Simple Steps to Induction Cooking

- 1. Turn it On:** To begin, plug in the Smart Hub™ and hold the power button.

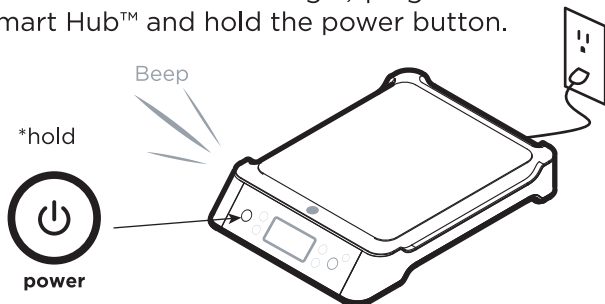

- 2. Set the power level:** Set the power levels by pressing the up or down buttons.

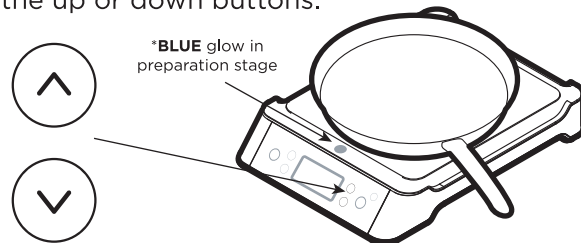

- 3. Start Cooking:** Press the start button to start heating the pan.

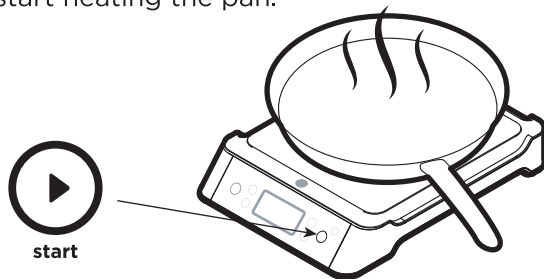

- 4. Turn it Off:** When finished cooking, you may hold the power button for two seconds to turn off the Smart Hub™.

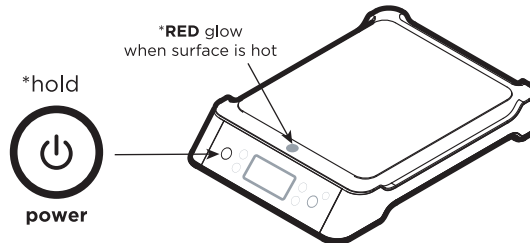

## Introducing the Oliso® Sous Vide Smart Top™

The Oliso® Smart Hub™ teams with the sous vide smart top to rapidly reach a precise temperature, and continue to maintain that temperature with minimal energy consumption. Additionally, the sous vide smart top may be removed, providing you with a cooktop for searing and other use.

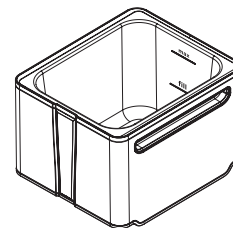
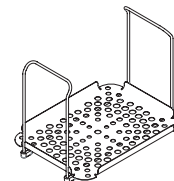
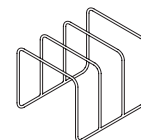
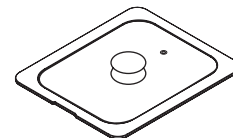
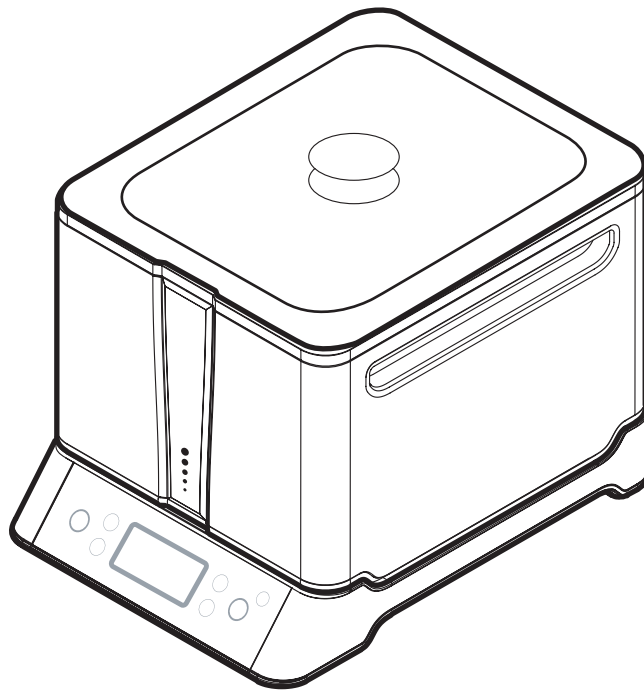

models ST95A, ST75A

# Using the Sous Vide Smart Top™

## Lid

The glass lid allows you to easily monitor food contents without interrupting the cooking process.

### DETAILS:

1. Steam vent
2. Glass viewing window
3. Lid handle - Stays cool to the touch.
4. Silicone rim - Has a rib on the underside to capture condensation as you lift the lid.

## Water Bath

The removable water bath is used for sous vide cooking. When the water bath is placed onto the Smart Hub™, the viewing screen will automatically enter sous vide mode.

### DETAILS:

5. Stainless Steel Water bath: Max capacity of approximately 10L or 2.6 gallons when filled to the max line with food and water.
6. Max fill line: Water to not exceed this line.
7. Fill line: Fill initially to this line.\*
8. Temperature Module: Transfers temperature information from the Smart Top™ water to the Smart Hub™ to regulate a precise temperature.
9. Extended side handles: Extra wide handles offer better handling and facilitates the pouring of water for either left or right handed users.
10. LED indicator light: This feature helps to inform you when the bath temperature has reached the set value. The light turns green to indicate that your set temperature has been reached. Food may then be placed into the water bath.

## Lid:

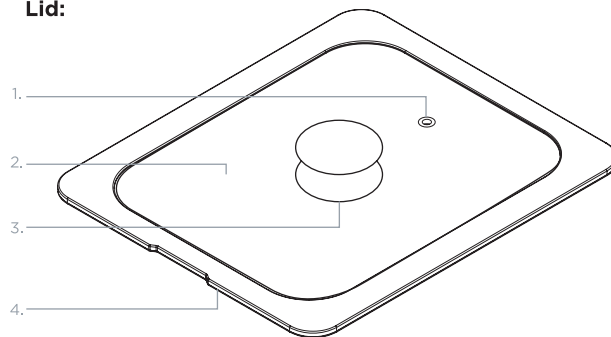

## Water Bath:

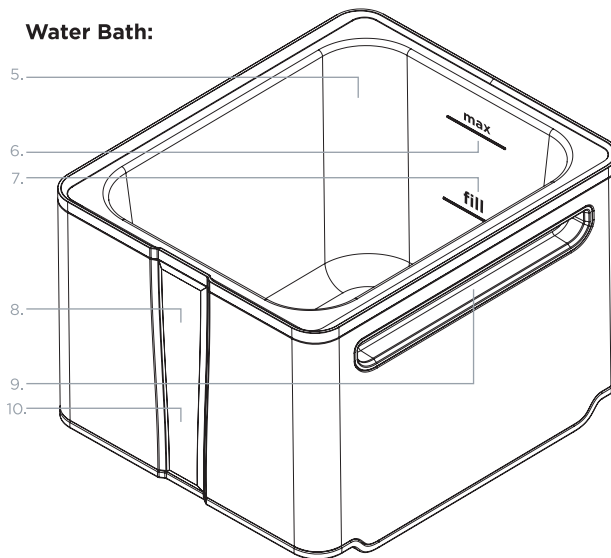

\*CAUTION: Do not start heating without water in the water bath.

# Using the Spacer Plate and Rack

## Perforated Spacer Plate:

With induction cooking, the bottom of the pan will heat rapidly. This spacer plate helps ensure food is cooked evenly, by spacing the bags away from the hotter bottom surface, and allowing the water to evenly disperse through the perforations. It also has two handles for easy removal, and silicone feet to protect the metal finish of the water bath. The slotted food rack sits atop the spacer plate, and organizes your sous vide pouches within the water bath. The rack may be oriented in different positions to accommodate longer or thicker pouches.

Food in sealed Vac Snap bags should be placed in the racks allowing space between each of the bag and so that all sides of the bag are in contact with the water. Avoid overcrowding of the bath which will prevent contact with the water and limit the ability for the heat to transfer during cooking. For larger items remove the rack.

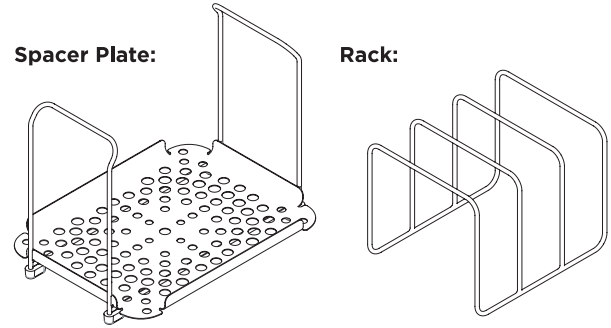

Bird's Eye View

4 sections for Vac Snap® Bags to be placed vertically

3 sections for longer food items

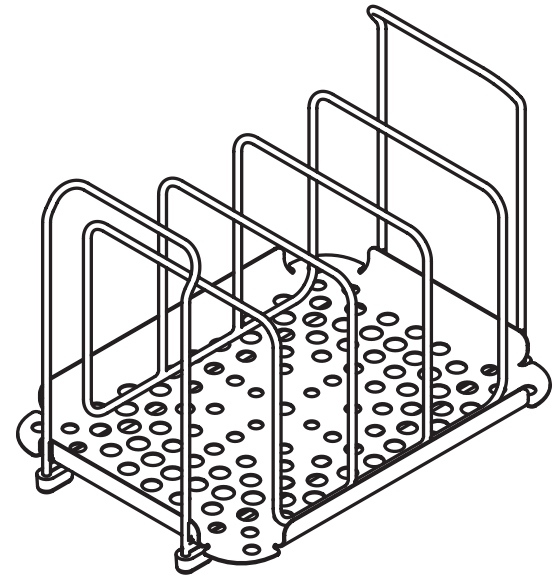
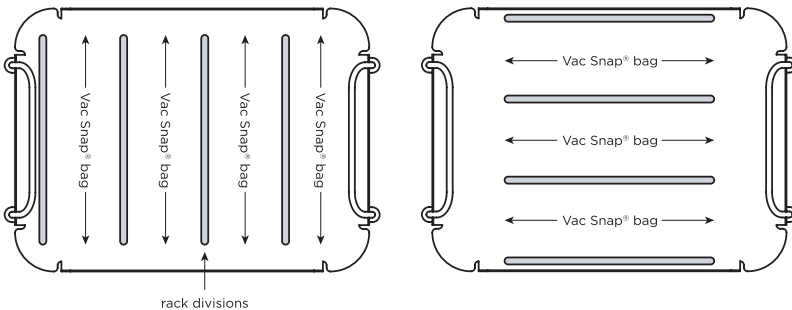

## LCD Viewing Display Contents for Sous Vide Cooking

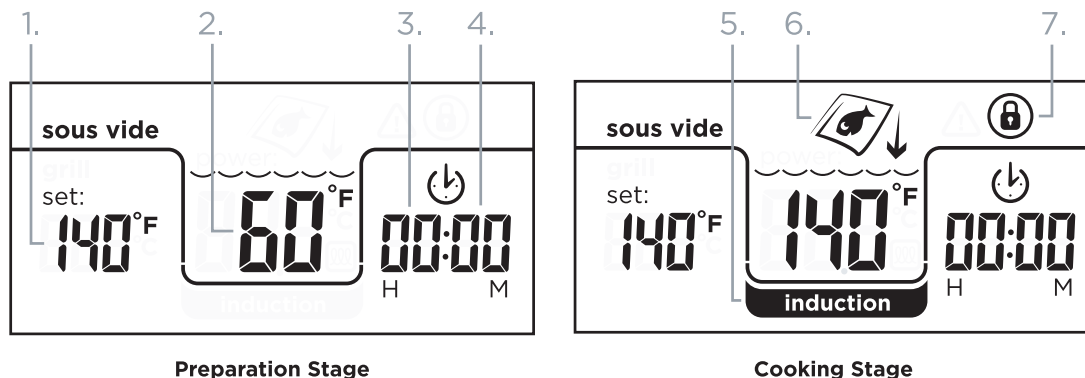

**Sous Vide Mode:** (Sous Vide Smart Top™ is placed on the Smart Hub™)

1. SET TEMP - Displays the current temperature setting
2. BATH TEMP - Displays the actual temperature of the water within the Smart Top™.
3. HOUR - Displays the hour setting of the timer
4. MIN - Displays the minute setting of the timer
5. INDUCTION - This icon is displayed once the START button has been activated, and the unit is heating.
6. PLACE FOOD - Once the set temperature is reached, this icon is displayed to communicate that it is ready for you to place food into the bath.
7. LOCK - This icon is visible when the child lock feature is active. This feature prevents accidental setting changes.

## Simple Steps to Sous Vide Cooking

**1. Turn it On:** To begin, plug in the Smart Hub™ and hold the power button.

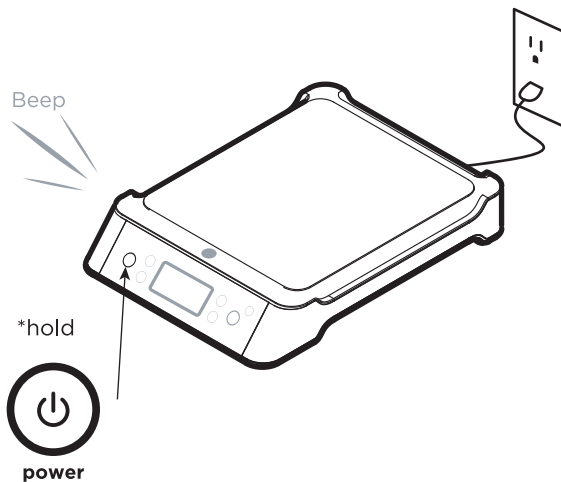

**2. Join:** Gently place the Smart Top™ onto the Smart Hub™.

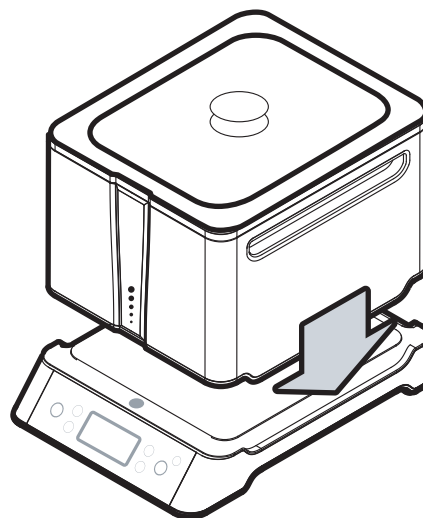



## Simple Steps to Sous Vide Cooking

**3. Fill, Select Temperature:** Fill the Smart Top™ with water until it reaches at least the fill line. Toggle to your desired temperature.

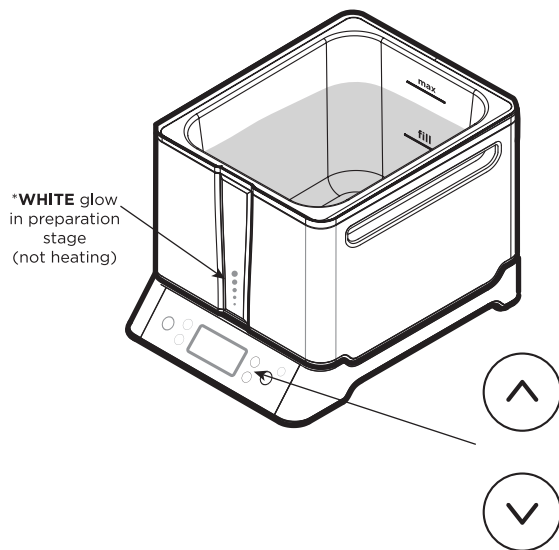

**4. Start:** Fill the Smart Top™ with water until it reaches at least the fill line. Toggle to your desired temperature, and press start to begin heating the water.

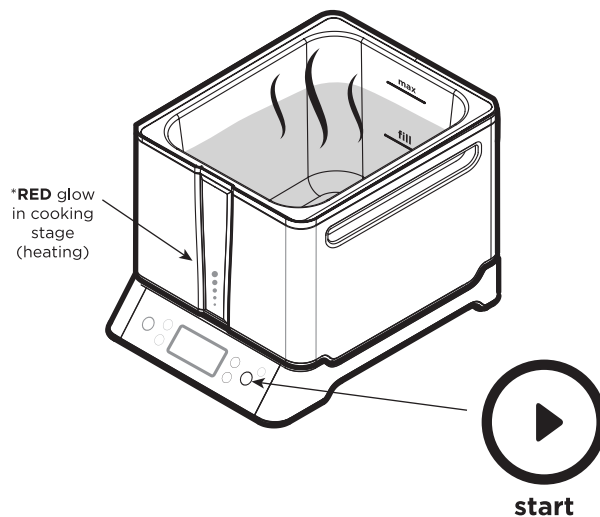

## Simple Steps to Sous Vide Cooking

**Intermission:** While the water heats up, this is a good time for food prep and vacuum sealing! If you're new to Oliso®, check out our punch and seal Smart Vacuum Sealer™!

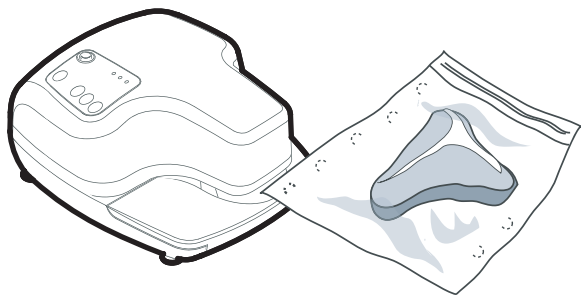

- resealable zipper top bags
- small countertop footprint
- small sealing area is great for sealing liquids and marinades

**5. Dunk:** Use tongs to fully submerge the food in water once the set temperature has been reached. Give each bag enough space allowing water to circulate around each bag.

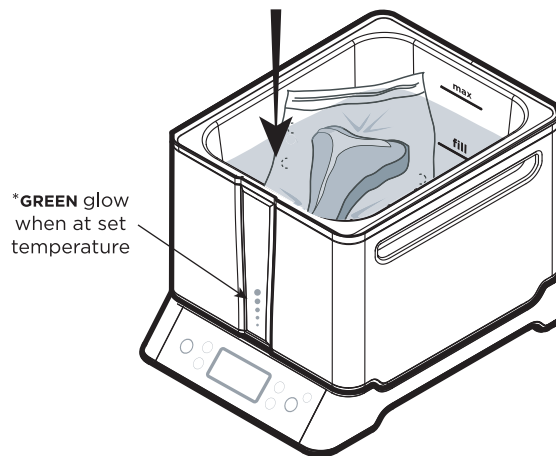

## Simple Steps to Sous Vide Cooking

**6. Optional timer setting:** You can press the timer button to set a timer. When the temperature is stable, you can activate the timer by pressing start.

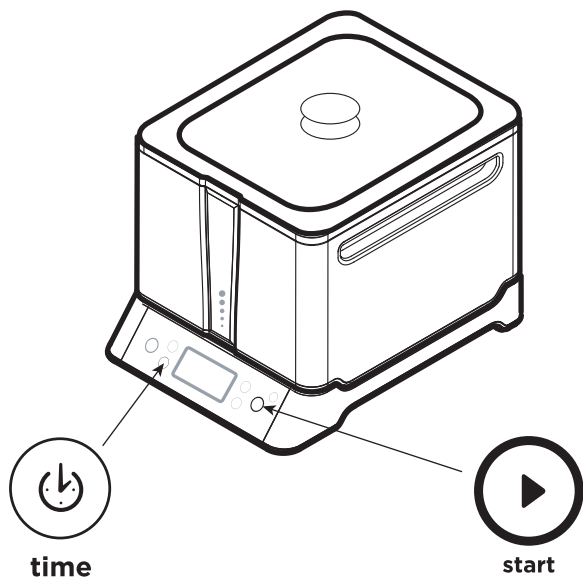

**7. Turn it off:** When finished cooking, turn the power off by holding the power button for two seconds.

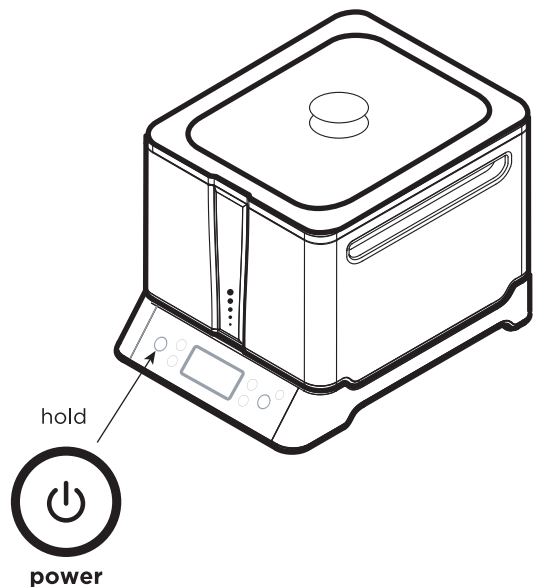

## Technical Information

Rating Voltage: 120VAC, 1500W

### **Settings for regular induction cooking:**

Power Range: 0-10. The appliance will default to power level 5.

Timer Range: 99:59 (Hours:Mins)

### **Settings for cooking Sous Vide:**

Temperature Range: 86°F to 194°F (30°C - 90°C). Default temperature is 140 degrees Fahrenheit.

Timer Range: 99:59 (Hours:Mins)

## Quick Tips

- To quickly reset a timer back to '00:00', you can touch and hold the timer button.
- To reduce the time it takes to reach your set temperature, you can start with hot water from the tap.
- Don't lose your Zip Disc! The magnet built into the Zip Disc allows it to be stuck on the metal wrap of the water bath.
- If transporting the water bath with water inside, the glass lid will help to prevent splashing.
- To help organize your cooking items, you can number or write times directly on the Vac Snap bags.
- As sous vide cooking is already a low temperature process, it's best to bring cooked food quickly to the plate, searing surface, or chilling bath.
- Because it is difficult to overcook food with sous vide cooking, when working with multiple food items, you can often leave the rest of the vac snap bags in the water bath and finish one food item at a time.

### **LED indicator light for reference at a glance (LED light seen above the LCD):**

#### WHILE USING REGULAR INDUCTION READY PAN:

Soft blue glow: Setting mode, heat is not active.

Soft red glow: Heating mode, heat is active.

Bright red glow: Indicates that the cooking surface may be hot to the touch. Will remain active even after the unit is turned off, but still plugged in.

#### WHILE USING THE SOUS VIDE SMART HUB™:

White glow: Setting mode, heat is not active.

Red and pulsing: Heating mode, heat is active. Actual temperature does not match the set temperature.

Green glow: Set temperature has been reached. Heat is still active.

Green and pulsing: Set temperature has been reached, and the timer is actively counting. Heat is still active.

#### EITHER MODE:

Yellow and flashing: Helps indicate an error function. Heat is not active.

## Care and Maintenance

- Please remove the power plug prior to cleaning the induction cooktop. Do not use any abrasive cleaning agents and make sure that water does not enter the induction cooktop.
- Never immerse the induction cooktop, its cables or the plug into water or other liquids
- Wipe off the glass cooktop with a damp cloth or use a mild, non-abrasive soap solution.
- Wipe off the casing and the operating panel with a soft cloth or a mild detergent.
- Do not use any oil based cleansing products in order not to damage the plastic parts or the casing.
- In order to keep your cooktop looking new, make sure that the bottom of your cookware does not scrape the glass surface, although a scratched surface will not impair the use of the induction cooktop.
- Make sure to properly clean the unit before storing it in a cool, dry place.
- For any other service or maintenance, please visit our website and contact a service representative.

### **When using the Sous Vide pan:**

- Do not leave water sitting in the bath after use. Allow bath to cool, remove food rack and spacer plate, and use the extended side handles to lift the sous vide pan off and pour water into the sink. To lessen the weight, you may scoop some water out using a cup before lifting the sous vide pan.
- Periodically, or if a cooking pouch ruptures, you may need to clean the water bath. Use a soft cloth or sponge with mild soapy water to wipe out the interior of the water bath. You may then rinse with water, and pour out the liquid.

## Troubleshooting

### **I set my food to the correct bath temperature and it started to cook, when I went away and returned the unit was turned off, what should I do?**

Most importantly, DO NOT CONSUME YOUR FOOD - DISCARD IT IF THERE IS ANY QUESTION TO THE FOOD SAFETY. There seems to be a problem with your power input at the location. Please make sure to plug the unit back into a circuit that is not overloaded. The unit will also power off if left idle after timer expires (except when using the water bath).

### **There is a lot of scale forming at the bottom of my unit, what can I do to clean it?**

You can use White Vinegar to clean the scale off the bottom of your pan. Make sure not to use abrasive cleaners or scrubbers as it could damage the coating on the surface. Also make sure after the bath cools to drain, clean and dry the pan before storing, so that the pan can be kept spick and span.

### **How can I determine how much water to put in to the water bath, to prevent overflowing?**

Fill the water bath to the fill line with water at room temperature. Place the vacuum packaged food items into the bath. If food contents are not fully submerged, you may add water until the water level reaches the max line. You may now remove the food items, and start preheating the bath.

### **Can I drop frozen food in, when the bath is ready?**

Please use caution when cooking foods from a frozen temperature. There is no way to know the proper cooking time using this method. Additionally, there is no way to know if the raw product was of good quality and safe to eat.

## Troubleshooting - Error Codes

Error Code	Seen during which mode?	Cause	Solution
- -	induction	No pan or unsuitable pan	Place a suitable pan on the unit.
E01	both sous vide & induction	Temperature is too high or a component has shorted	Make sure there is a minimum distance of 5 inches between the ventilation slot (found at the back of the induction Cooktop) and any obstruction such as a wall or other appliances. Unplug, let the unit cool down, plug back in and press the power button.
E02	both sous vide & induction	Component failure	Unplug the unit from the outlet. Wait five minutes. Plug the unit back in and turn on. If error code persists, contact customer service.
E03	Both sous vide & induction	Voltage is either too low or too high.	Make sure the unit is connected to an outlet with the correct voltage.
E04	sous vide	Water bath is empty	Add water to the fill line
E05	sous vide	Component failure	Contact us for further troubleshooting or repair.
E06	sous vide	Programming error	Contact us for further trouble-shooting or repair



# Warranty

Oliso, Inc. warrants that for a period of one year from the date of the original purchase, this product will be free from defects in material and workmanship, when utilized for normal household use. Oliso®, Inc. will repair or replace this product or any component of the product found to be defective during the warranty period without charge to the customer. If a replacement product is sent, it will carry the remaining warranty of the original product. Replacement will be made with a new or remanufactured product or component. If the product is no longer available, replacement may be made with a similar product of equal or greater value. This is your exclusive warranty.

This warranty is valid for the original retail purchaser from the date of initial retail purchase and is not transferable. Keep the original sales receipt. Proof of purchase is required to obtain warranty performance. Oliso, Inc. dealers or retail stores selling Oliso, Inc. products do not have the right to alter, modify or in any way change the terms and conditions of this warranty.

The liability of Oliso, Inc. is limited solely to the cost of repair or replacement of the product at its option. This warranty does not cover normal wear of parts and does not apply to any product that has been tampered with or used for commercial purposes. This warranty does not cover damage caused by misuse, abuse, use on improper voltage or current, use contrary to the operating instructions, negligent handling or damage due to faulty packaging or mishandling in transit. This warranty does not cover damage or defects caused by or resulting from damages from shipping or repairs, service or alteration to the product or any of its parts, which have been performed by a repair person not authorized by Oliso, Inc. Further, the warranty does not cover Acts of God such as fire, flood, hurricanes, and tornados.

This warranty is extended to the original purchaser of the product and excludes all other legal and/or conventional warranties. The responsibility of Oliso, Inc. is limited to the specific obligations expressly assumed by it under the terms of the limited warranty. In no event shall Oliso, Inc. be liable for any incidental or consequential damages caused by breach of any express, implied or statutory warranty or condition.

Except to the extent prohibited by law, any implied warranty or condition of merchantability or fitness for a particular purchase is limited in duration to the duration of the above warranty. Oliso, Inc. disclaims all other warranties, conditions, or representations, express, implied, statutory or otherwise. In no event shall Oliso, Inc. be liable for any indirect, special, incidental or consequential losses or damages (including but not limited to interruption of business or loss of business or profit) resulting from the use of or inability to use the product, any breach of contract, fundamental or otherwise, or for any claim brought against purchaser by any other party. Some states or jurisdictions do not allow the exclusion or limitation of incidental or consequential damages or limitations on how long an implied warranty lasts, so the above limitations or exclusion may not apply to you. If you have any question regarding this warranty or would like to obtain warranty service, please email Oliso, Inc. at [customerservice@oliso.com](mailto:customerservice@oliso.com), and a service center address will be provided to you.

If you have further questions, you may call 1-800-899-5157.

## Thanks

**Thank you for purchasing the Oliso® Smart Hub™, a safer, smarter way to cook.**

**Please note:** Some Oliso® Smart Hubs™ may look slightly different than the irons illustrated here. For a complete review of current Oliso® Smart Hub™ models, please visit [www.oliso.com](http://www.oliso.com).

©2015 Oliso, Inc. All rights reserved. Oliso is a registered trademark of Oliso Inc. Smart Hub, Smart Top, and Smart Vacuum Sealer are trademarks of Oliso Inc. Patents Pending. #69001021 <12/14>A Printed in China