

## SILENT WALLMOUNT RANGEHOOD // 90cm

SC900WRS

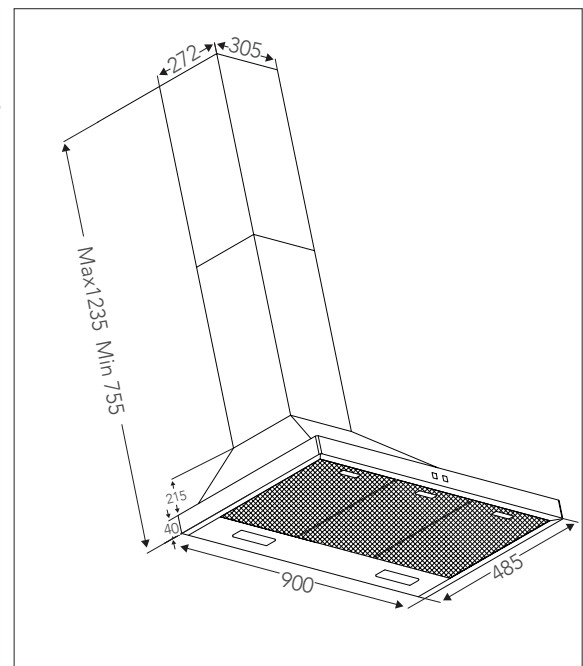

- **Easy to use** - this stainless steel wallmount rangehood is striking in its appearance, and remarkable in its practical performance.
- **Silent extraction** - paired with an externally mounted motor for effective extraction of steam, smoke and odours, leaves your kitchen air fresher.
- **Strong lighting** - incandescent lighting over the cooking zone.
- **Mesh filters** - aluminium, dishwasher safe.



**INSTALLATION** A qualified, professional technician is recommended.

**CLEANING AND MAINTENANCE** Easy to clean stainless steel using only recommended stainless steel cleaning products. No abrasives, corrosive detergents, bleaches or acids are required.

Description	Technical data	Motor power
<ul style="list-style-type: none"> <li>• Stainless steel finish</li> <li>• Silent external motor system</li> <li>• Single speed with switch button controls</li> <li>• Incandescent lighting</li> <li>• Aluminium, dishwasher safe filters</li> </ul>	<ul style="list-style-type: none"> <li>• Dimensions: (W x D) 900 x 485 mm</li> <li>• 3 x aluminium mesh filters</li> <li>• 2 x 25W incandescent light bulbs</li> </ul>	<ul style="list-style-type: none"> <li>• Single external Hi Flow motor system, 600m<sup>3</sup>/h airflow, 150mm flexi ducting (4m), installs in roof/wall/eaves</li> </ul>



Scandium® kitchen appliances covered by a 3 Year Warranty, and is serviced by our experienced Australian Customer Care network.

Product specifications subject to change without notice, images are for illustrative purposes only. Please check final product details with your retailer. © 2018. Axis Group International Pty Ltd.

AUSTRALIA 8/3-4 Anzed Court, Mulgrave VIC 3170.  
Phone 1300 881 693 Email [info@scandiumappliances.com.au](mailto:info@scandiumappliances.com.au)  
Web [www.scandiumappliances.com.au](http://www.scandiumappliances.com.au)

NEW ZEALAND 5 Tolich Place, Henderson, Auckland 0610.  
Phone 0800 200 510 Email [info.parex@emerson.com](mailto:info.parex@emerson.com)  
Web [www.parex.co.nz](http://www.parex.co.nz)