



# USER MANUAL

Model: T10 PRO



# TABLE OF CONTENTS

Safety Warning ..... 02

Inside the Box ..... 04

Product Description ..... 05

Product Operation ..... 08

Product Maintenance ..... 13

Product Specifications ..... 16

Troubleshooting ..... 17

## SAFETY WARNING

### IMPORTANT SAFETY INSTRUCTIONS FOR HOME USE ONLY

Basic precautions should always be observed when using any electrical equipment, including the following:

**WARNING: READ ALL SAFETY INSTRUCTIONS AND THE ENTIRE MANUAL.** Failure to heed the warnings and instructions may result in electric shock, fire, or serious injuries. Please read all instructions before using this robot.

#### WARNING:

- This robot is intended for children 8 years of age and older. People with reduced physical, sensory, or intellectual abilities, or those who lack experience and knowledge, should be supervised or instructed in safely using the robot; they must also be aware of possible hazards. Children should not play with this robot. Cleaning and user maintenance should not be performed by children without supervision.
- The robot must be used in accordance with the instructions in this manual. The company is not responsible for any damage or injury caused by improper use.

**To reduce the risk of injury or damage, please observe the following safety precautions when installing, using and maintaining the robot:**

- Please read all instructions regarding safety and operation before using the robot.
- Keep the safety and user manual for future reference. If you accidentally lose the manual, you may visit the official website to download the electronic version. (<https://www.ultenic.com>).
- Heed all warnings on the robot, battery, charging station, and user manual.

 Follow all operating and usage instructions.

The product's labels or packaging indicate that: Do not dispose of the electrical appliances as unsorted waste or, use a separate waste collector.

Contact your local authority for information on the appropriate disposal method. If electrical appliances are discarded in landfills, hazardous substances can leach into groundwater, enter the food chain, and damage people's health. Contact your local or regional waste management agency for more information on their recycling and reuse programs.

### RESTRICTIONS

- This robot is for indoor use only. Do not use it outside, or in commercial and industrial environments.
- Before using the robot, remove fragile items such as clothing, loose-leaf paper, rope or curtains, and power cords from the floor. The robot may snag onto an object, table, or shelf if it gets stuck on a cable.
- This robot is not a toy. Do not sit or stand on this robot. Children and pets should be supervised while the robot is operating.
- Store and operate the robot at room temperature.
- Do not use this robot to clean anything that is burning or smoking.
- Do not use the robot to clean bleach, paint, or other chemicals, or anything wet.
- If the cleaning area involves a balcony, a physical barrier should be set up to prevent the robot from accessing the balcony and ensure it operates safely.
- People (including children) with reduced physical, sensory, or intellectual abilities, or those who lack experience and knowledge, should be supervised or instructed in safely using the robot.



- **Children should be supervised to ensure they do not play with the robot. Further, cleaning and maintenance must not be performed without adult supervision.**
- Do not place anything on the robot.
- Please note the robot will move on its own. Try to be careful when walking in the operating area to avoid stepping on it.
- Do not operate the robot in an area where a ground power outlet is exposed.

## BATTERY AND CHARGING

- Only use rechargeable battery packs with specifications approved by our company.
- Use the standard complimentary charging station for charging. This product must not be used with any type of power adapter; the use of other power adapters will immediately void the warranty.
- Do not use a charging station with a damaged power cord or plug. If the power cord or plug is damaged, it must be repaired by the manufacturer or a similarly qualified party.
- Ensure to charge and remove the batteries in the robot and accessories before long-term storage or transportation.
- The remote control battery type is AAA alkaline battery.
- To replace the remote control's batteries, slide the battery cover on the back of the remote control open, remove the battery cover, and replace the batteries.
- Charge the robot indoors only.
- Your robot's charging station may be protected by a surge protector to prevent power surges.
- Do not operate the charging station with wet hands.
- Before cleaning or maintaining the robot, the plug must be removed from the socket.
- Ensure the voltage rating of the enclosed charging station matches the voltage of the standard outlet.
- Used battery packs should be placed in a sealed plastic bag and disposed of safely in accordance with local environmental regulations.
- Before each use, inspect the battery pack for signs of damage or leakage. Do not charge damaged or leaking battery packs.
- If the battery pack leaks, please contact Customer Service.
- The battery pack must be removed from the robot before disposal.
- Do not crush or disassemble the battery pack. Do not apply heat to the battery pack or place it near any heat source.
- Do not incinerate the battery pack. Do not short-circuit the battery pack.
- Do not immerse the battery pack in any liquid.
- Do not crush or disassemble the robot.

## INSIDE THE BOX

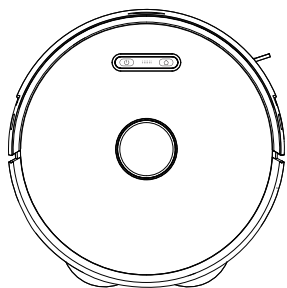

Robot

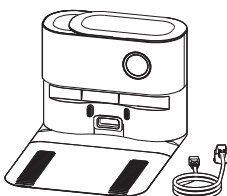

Charging Station



Remote Control



Mop\*4



Rag Bracket\*2

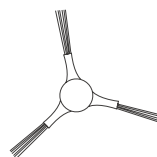

Side Brush

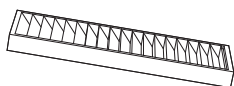

HEPA Filter

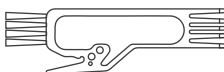

Cleaning Brush

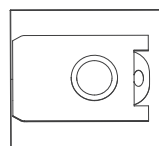

Dust Bag

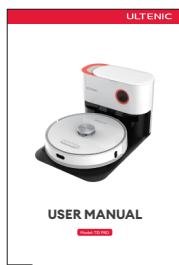

User Manual

# PRODUCT DESCRIPTION

## The Robot

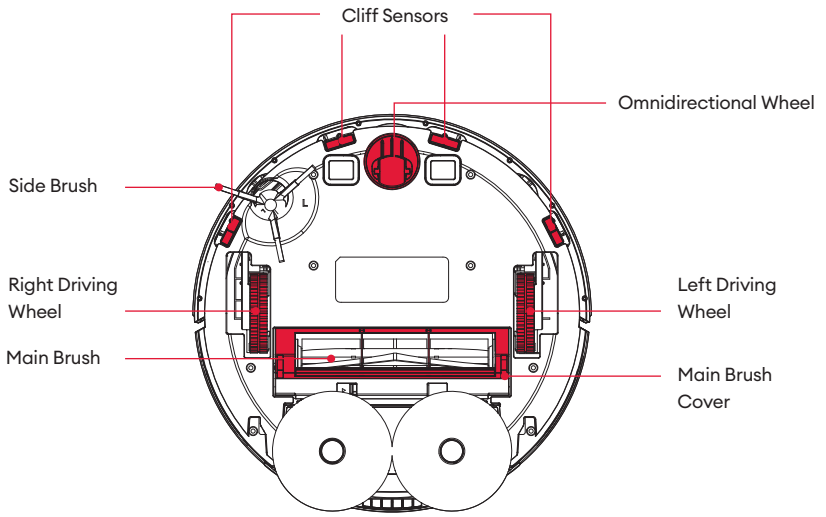
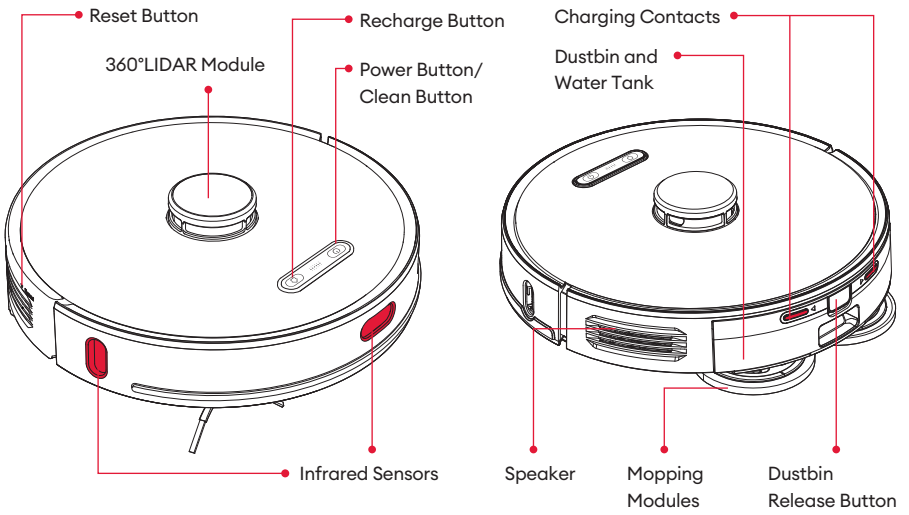

## PRODUCT DESCRIPTION

### 2-in-1 Dual Rotating Dustbin and Water Tank

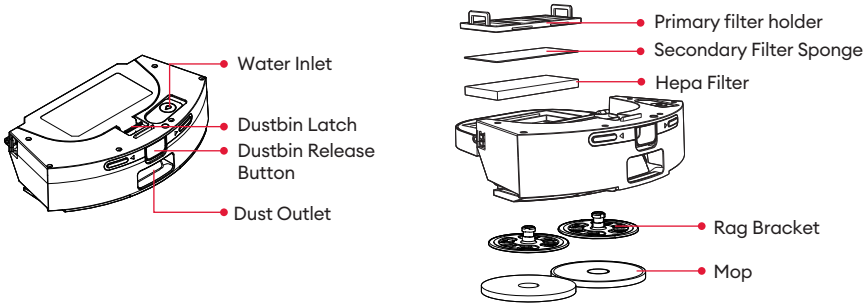

### Charging Station

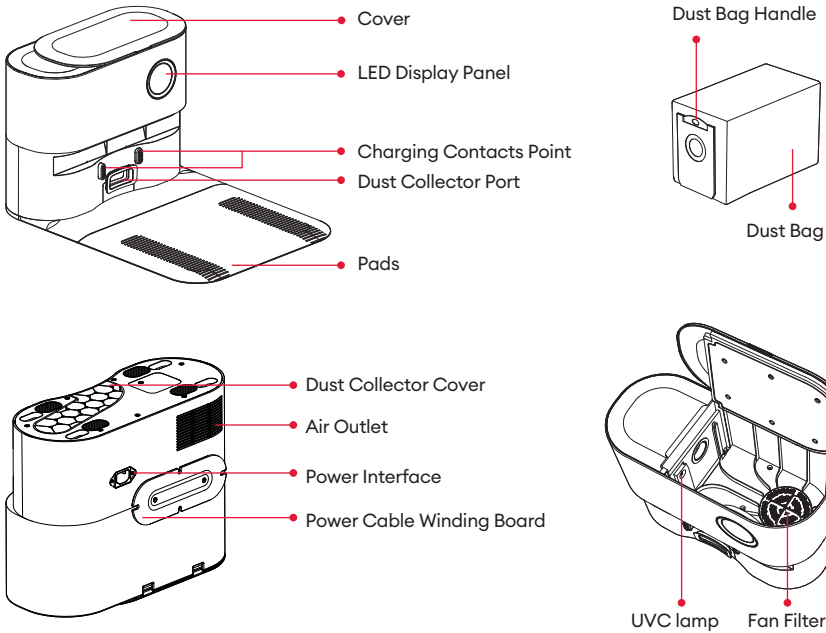

#### NOTE:

- 1: One dust bag already pre-installed in **Charging Station**.
- 2: It is normal for the dust bag may appear "deflated".
- 3: Dust bag handle must be fully lowered as shown in order for debris to enter properly.

## PRODUCT DESCRIPTION

### Robot Indicator Lights

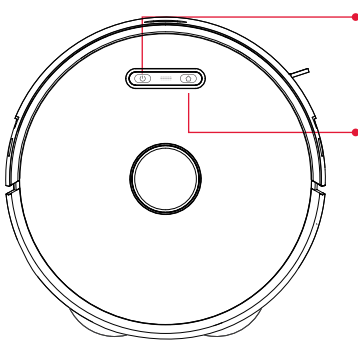

#### Power Button

- Long press 3S to turn on/off.
- Short press to start/pause cleaning.

#### Recharge Button / Recharge & Power Indicator

Press the button to return the robot to the charging station.

Press and hold the recharge and start/stop buttons at the same time for 5s to enter network configuration mode.

**Blue breathing light:** power on/upgrading firmware

**Steady blue light:** standby/normal working state

**Blinking yellow light:** low battery

**Green breathing light:** charging

**Steady green light:** fully charged

**Flashing red light:** error

### Charging Station Indicator Light

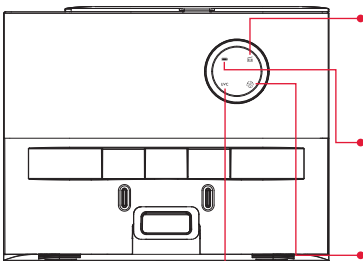

#### Dust Bag Indicator

- Solid white light: Dust bag is full/dust duct is blocked
- Flashing red light: Dust bag is not installed/dust bag is not installed correctly

#### Power Indicator

- Flashing green light: Charging.
- Solid green light: Standby.

#### Status Indicator

- Solid white light: Collecting dust.
- Flashing red light: Fan overheating/fan error/cover not closed.

#### UVC Sterilization Indicator

- Solid white light: Sterilizing on
- Light off: Sterilizing off

## PRODUCT OPERATION

### Before Using

Before use, remove all protective parts from the robot and charging station.

#### 1. Assemble the pads.

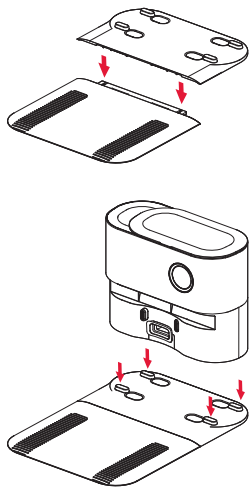

#### 2. Set up the charging station.

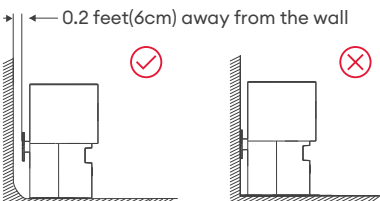
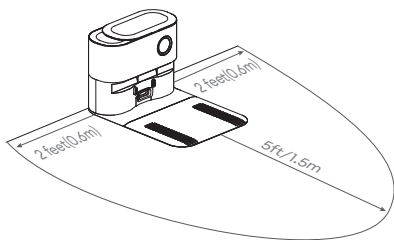

The Charging Station is designed to automatically empty and charge the Robot. Place on a flat, hard surface at least 0.2 feet (6cm) away from the wall. Ensure that there is a clear space in front and on both sides so that your Robot can return to Station to recharge and empty.

#### 3. Assemble power cord for charging station.

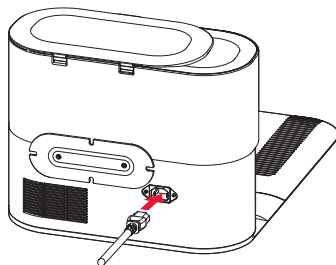

#### 4. Charge Robot.

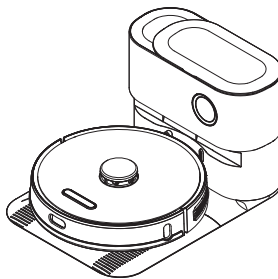

**Note:** The charging station must always be connected to the power supply. Avoid using power supplies that may be accidentally turned off (e.g. power strips, outlets controlled by light switches, GFCI).

## PRODUCT OPERATION

### App Connection

To use all available functions, we recommend using the app to control your robot.

#### APP Downloading and Installation



1. Download app from the App Store (for iOS) or Google Play (for Android).
2. Open the app and create an account.
3. Tap "+" icon to add "T10 Pro" to your account.
4. Follow instructions in the app to set up Wi-Fi connection.

#### Before starting, ensure to:

1. Connect your phone to a Wi-Fi network.
2. Activate the 2.4 GHz band on the router.
3. Check whether the wifi indicator light on the robot is flashing.

#### Manual connection

1. Press and hold the "⏻" button and the "🏠" button for 5 seconds until the indicator light flashes and the network converges.
2. Select the wifi router your phone is connected to, and enter the password.
3. Go to settings and WLAN list to connect to the hotspot "Ultenic-T10 Pro-XXXX".
4. Go back to the Ultenic app and complete the wifi connection.

### Bluetooth Connection

1. Turn on Bluetooth on your phone and scan for nearby Bluetooth devices.
2. Select the robot's model number.
3. Enter the wifi password to complete the connection.

### Operate via the Robot's Control Panel

#### Start / Pause

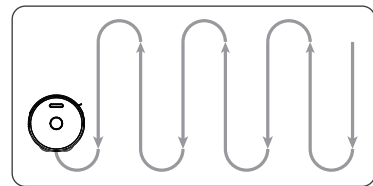
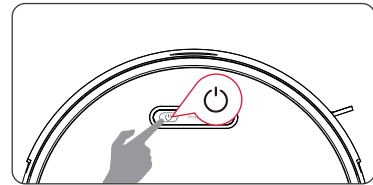

#### Recharge

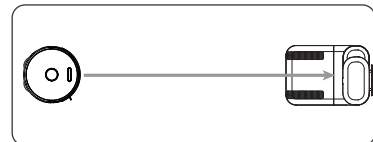
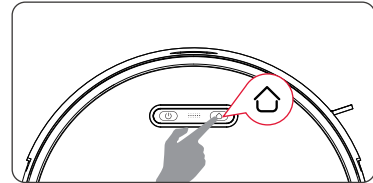

## PRODUCT OPERATION

Press the "⏻" button on the robot to activate.

**Note:** The robot control panel will stop lighting up after the robot has stopped for a few minutes. Press the "⏻" button on the robot to activate.

**Note:** When the robot is not in use, it is recommended to keep it on and charged.

### Operate via Remote Control

**Note:**

1. For a better experience of the remote control function, it is recommended to operate it right in front of the robot.
2. The remote control's control range is 10-20 feet.

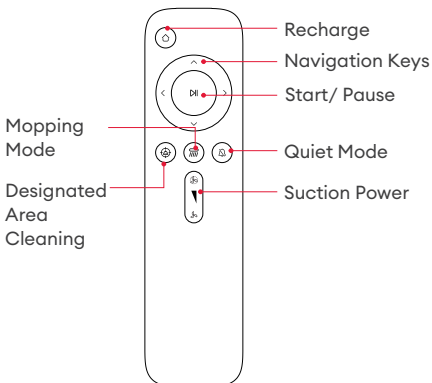
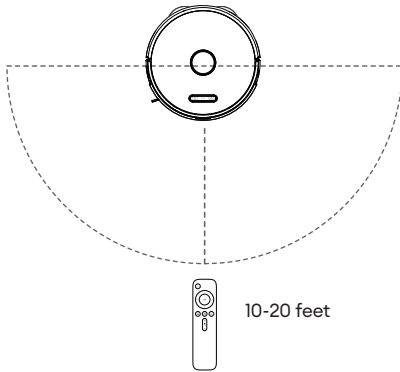

### Start / Pause

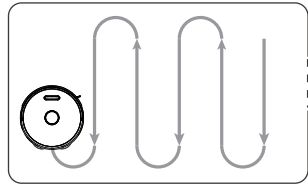

### Navigation Keys

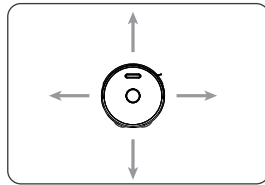

### Recharge

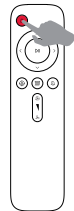
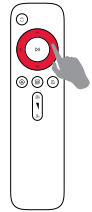
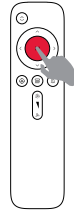
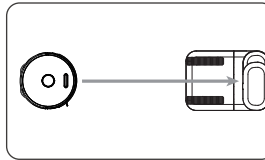



## PRODUCT OPERATION

### Mopping System

#### Note:

1. To extend the life of the dustbin and water tank, it is recommended to use deionized or demineralized water for mopping.
2. **Remove the mop modules before cleaning any carpets.**
3. Empty the water tank after mopping is finished.

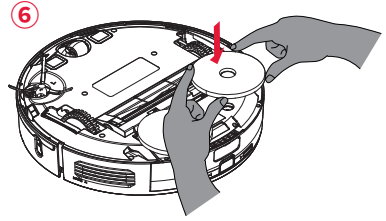
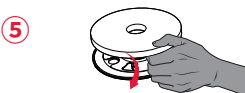
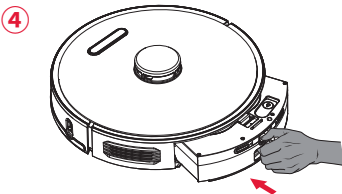
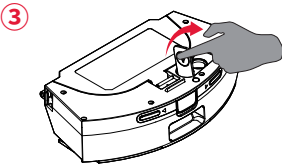
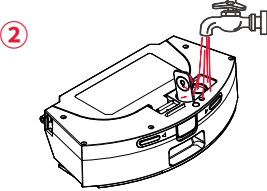
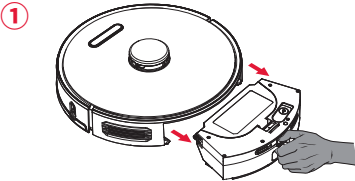

### Dust Collection System

The Auto Empty Station will indicate when the dust bag is full on the smart LED display panel. (" " is white)

**Note:** The charging Station will not collect dust when the dust bag is removed.

1. Open Cover;
2. Pull up the dust bag from the handle;
3. Discard the old dust bag;
4. Replace with new dust bag;
5. Close Cover.

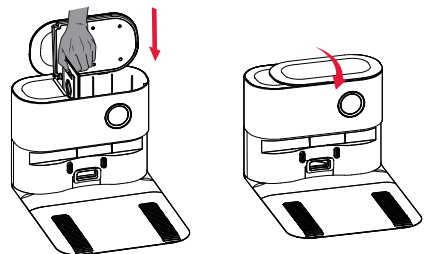
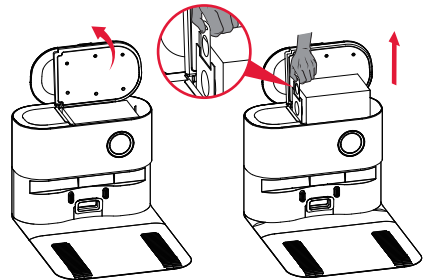

## PRODUCT OPERATION

### Cleaning Precautions

A. Please remove power cords and small objects from the floor that may entangle the robot.

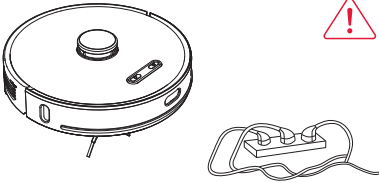

B. Please fold the tasseled edges of area rugs underneath to prevent tangling.

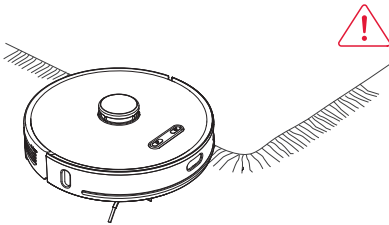

C. We strongly recommend prohibiting the use of robots in front of fireplaces and in certain areas (eg: vents).

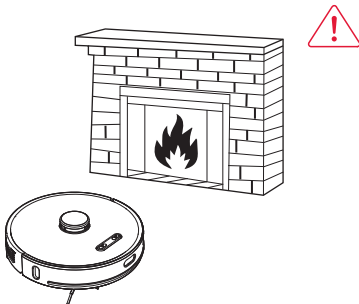

D. Keep the robot away from wet areas.

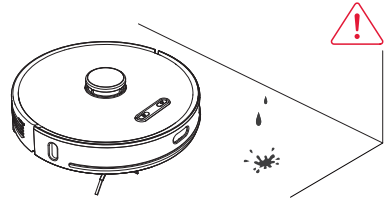

E. The Robot can climb over objects less than 0.59 in/15 mm in height. Remove these objects if possible.

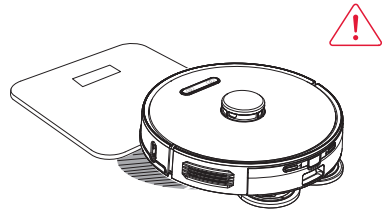

F. Anti-drop sensors can prevent the robot from tumbling down stairs and dropping. While reflective or dark-colored floors may affect the sensors' effectiveness, we recommend physically blocking off areas where the robot may fall.

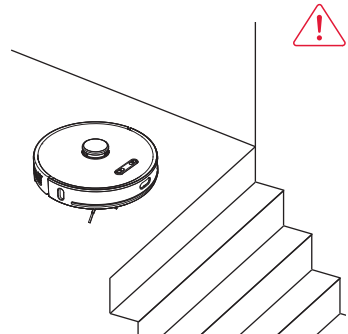

## PRODUCT MAINTENANCE

### Mopping Modules

Before cleaning and maintaining the robot, turn the robot off and unplug the charging station from the outlet.

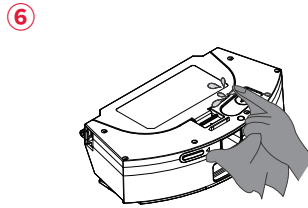
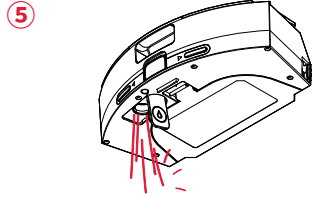
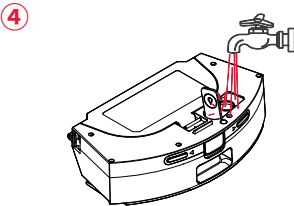
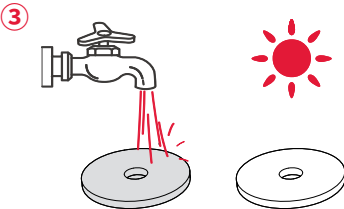
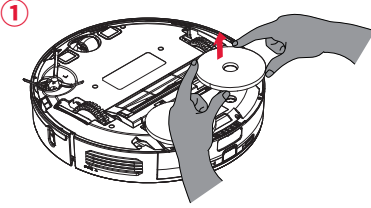

1. Remove the mop modules from the robot after each use.
2. Thoroughly rinse the mop cloth and water tank with water and empty the tank.
3. Sun-dry or dry wipe the mop cloth and water stains in the water tank to avoid mildew or odor.

## PRODUCT MAINTENANCE

### Dustbin and Filter

1. Press the release button and pull out the dustbin.
2. Open the cover.

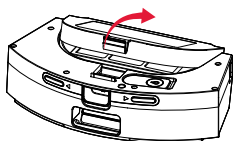
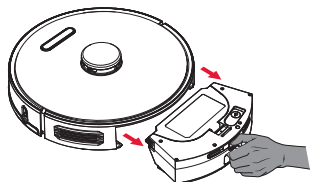

3. Remove the HEPA filter.
4. Tap the HEPA filter and primary filter holder to remove dust.

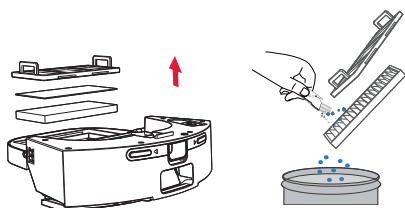

5. Rinse the Primary filter holder and HEPA filter with water.
6. Please completely air dry the HEPA filter before next use.

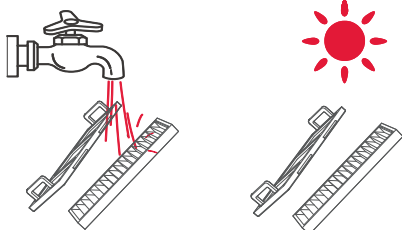

7. Put the HEPA filter back in the dustbin.
8. Attaching the dustbin back to the robot.

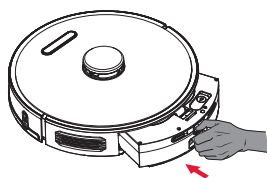
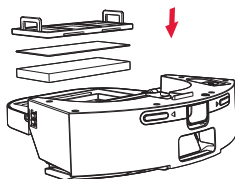

### Main Brush

**NOTE:** It can be used with a cleaning brush during maintenance. Please use the cleaning brush carefully.

①

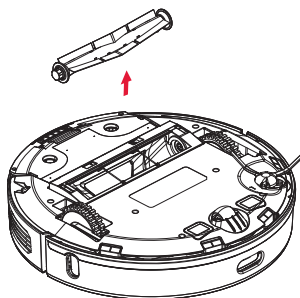

②



## PRODUCT MAINTENANCE

### Charging Station

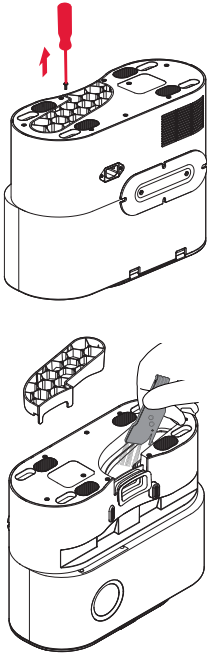

If the Robgot dustbin is not emptied or the "🌀" is solid white it may indicate that the charging station duct is blocked. Refer to the image: Unplug and turn over the charging station. Remove the pipe cover with a Phillips screwdriver and remove dirt or debris.

### Mapping Sensors

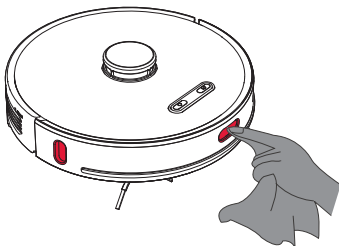

### Side Brush

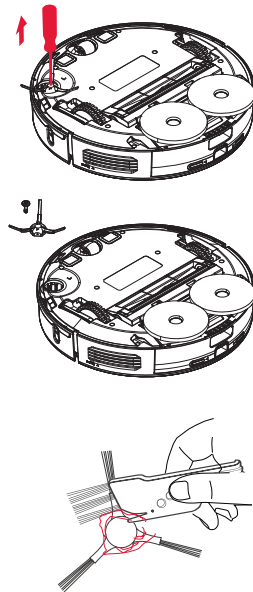

### Other Parts

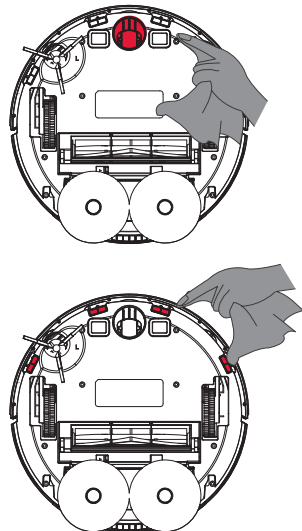

## PRODUCT MAINTENANCE

### Regular Maintenance

Maintain and replace parts at the following intervals to keep the robot running at optimal performance:

Parts	Maintenance Frequency	Replacement Frequency
Mop	Wash mop after each use	Every 3-5 Months
Side Brush	Every 2 Weeks	Every 3-6 Months
Roller Brush	Every Week	Every 6-12 Months
HEPA Filter	Every Week	Every 3-6 Months
Primary filter holder	Every Week	Every 3-6 Months
Dustbin	Every Week	/
Sensors, omnidirectional wheel, bumpers, robot	Every Week	/

**Note:** Our company manufactures a wide range of parts and accessories. For more information on accessories, please contact Customer Service.

## PRODUCT SPECIFICATIONS

Name	Parameters
Model	T10 Pro
Charing Time	≤5.5H
Robot Power Rating	50W
Rated Working Voltage	14.4V
Battery Capacity	5200mAh



## TROUBLESHOOTING

Conditions	Possible Issues	Solution
The robot can not connect to the app	Incorrect router username and password.	When connecting to the router network, please ensure you enter the correct "user name" and "password".
	The robot is not within the router's network coverage.	Ensure the robot is within the router's network coverage.
	The robot is not in a pending configuration mode.	The robot must enter the network configuration mode to connect to the wifi.
	Failure to use a 2.4G network.	The robot does not support 5G networks at the moment. Please use a 2.4G network when connecting to the Internet.
	The wrong app may have been downloaded.	Please scan the QR code on this product or visit the app market to download the app.
Can not recharge.	The charging contacts of the robot and the charging station are not fully connected.	Ensure the robot is fully docked with the charging station's charging contacts, and ensure the power button is flashing. Check whether the main unit's charging contacts and station are dirty. Please refer to the manual for cleaning instructions.
	The charging station is not placed in the correct position and/or was not placed as required.	You can refer to the chapter on precautions for correct placement of the charging station.
	The signal receiving lens is dirty.	Dirty lenses may disrupt signals from being received. Please refer to the maintenance chapter for cleaning instructions.
	Charging contacts are dirty and not in full connect.	After the robot and the charging station are fully in connect, and when the robot and charging station's status indicator light are in a breathing status, please check whether the charging contacts are dirty. Please refer to the maintenance chapter for cleaning instructions.

Can not recharge.	Too many obstacles near the charging station.	Please ensure the charging station has 2 feet of clear space on either side and 5 feet in front.
	The charging station is not connected to a power source.	Please ensure the power cord is connected (reference: charging station indicator light)
	Prolonged inactivity, resulting in over-discharge of the battery.	If the battery is not used for a long period and if the battery can not be charged due to over-discharge, please contact Customer Service.
	The robot is out of the charging station range.	Move the robot close to the charging station to re-establish the connection.
The robot became stuck while operating.	The robot is entangled or blocked by scattered wires on the ground, drooping curtains, carpet fringe, etc.	The robot will try various methods to disengage itself. If it fails, please manually untangle the robot.
	The robot may snag on a nearby piece of furniture.	
The robot keeps bumping into objects.	The infrared obstacle avoidance sensor lenses are dirty.	Periodically wipe the sensors with a dry cloth.
	The omnidirectional wheel are stuck.	Regularly check the omnidirectional wheel for entangled hair, wool, and other small objects.
The red light flashes when the robot is operating.	Abnormal prompt sound from the robot.	Handle according to the robot's voice and app prompts.
Excessive noise when operating.	Side/roller brushes are entangled, dustbin or filter materials are blocked, etc.	We recommend regularly cleaning and maintaining side brush, roller brush, dustbin, filter materials, etc.
	The robot entered ultra cleaning mode.	Change to standard cleaning mode.



The robot cleans in an unorderly route, exhibiting route deviation, repetitive cleaning, and/or missing small areas.	Wires and other easily entangled objects on the floor will affect the robot's operations.	Before cleaning, please remove scattered wires, mops and other objects from the ground. If the robot misses an area while scanning, it will automatically re-scan the area. Please do not interfere (such as moving the robot or interfering with its route).
	Objects such as thresholds and steps have caused the robot to slip and slide.	We recommend closing the door in the area and cleaning the area separately. The robot will return to the starting point after cleaning. Please feel free to use it.
	The robot can not enter and clean a certain area.	We recommend organizing the home environment to ensure the robot can access and clean any area.
	The infrared obstacle avoidance sensor lenses are dirty.	Wipe the sensor lens with a clean soft cloth or remove the blocked objects.
Decreased cleaning ability or dust shedding from the dustbin.	The dustbin is full.	Please check if the dustbin is full before checking and cleaning the HEPA filter. Finally, check the roller brush for obstructions.
	The HEPA filter is blocked.	
	The roller brush is obstructed.	
Water tank can not release water.	The water outlet is blocked.	Do not add other liquids such as disinfectant, perfume, etc., to the water tank.
Drive wheels are entangled	The drive wheel is entangled or has snagged on a foreign object.	Turn and press the drive wheel to check for foreign objects.
Sensor detection errors or sensor is not functioning	The sensor lenses are dirty	Wipe the sensor lens with a clean soft cloth or remove the blocked objects. Please contact Customer Service if you can not solve the issue.
Can not create a home map on the app.	The robot isn't deploying from the charging station.	The robot must start cleaning from the charging station.
	Can not complete automatic cleaning.	Allow the robot to automatically return to the charging station after cleaning.
The robot starts automatically at night or in the middle of the night.	The scheduled cleaning function is set.	Cancel scheduled cleaning in the app.
	The robot continues to clean where it stopped.	The robot will go back to station when the power reaches 80% when it is not finished cleaning.

pilot lamp	Possible Issues	Solution
 Flashing Red	Fan Error	1. Frequent dust collection leads to fan overheating protection or fan malfunction. It is recommended to try to collect dust after 30 minutes; 2. Ensure that the cover of the Charging Station is completely closed and the Robot is properly docked and charging.
	Overheating	
	The charging station cover is not closed properly	
 Flashing Red	The dust bag not installed in place	1. Ensure that the dust bag is properly installed and fully lower to the cardboard handle.
	The dust bag not installed	2. Check whether the dust bag is installed, if not, please install the dust bag.

### FCC Compliance Statement

This device complies with Part 15 of the FCC Rules. Operation is subject to the following two conditions: (1) This device may not cause harmful interference, and (2) this device must accept any interference received, including interference that may cause undesired operation.

**Warning:** Changes or modifications not expressly approved by the party responsible for compliance could void the user's authority to operate the equipment.

**Note:** This equipment has been tested and found to comply with the limits for a Class B digital device, pursuant to Part 15 of the FCC Rules. These limits are designed to provide reasonable protection against harmful interference in a residential installation. This equipment generates, uses, and can radiate radio frequency energy and, if not installed and used in accordance with the instructions, may cause harmful interference to radio communications. However, there is no guarantee that interference will not occur in a particular installation. If this equipment does cause harmful interference to radio or television reception, which can be determined by turning the equipment off and on, the user is encouraged to try to correct the interference by one or more of the following measures: (1) Reorient or relocate the receiving antenna. (2) Increase the separation between the equipment and receiver. (3) Connect the equipment into an outlet on a circuit different from that to which the receiver is connected. (4) Consult the dealer or an experienced radio/ TV technician for help.

### FCC Radiation Exposure Statement:

This equipment complies with FCC radiation exposure limits set forth for an uncontrolled environment. This equipment should be installed and operated with minimum distance 20cm between the radiator & your body.