

MANHOLE ASSM
TOP VIEW

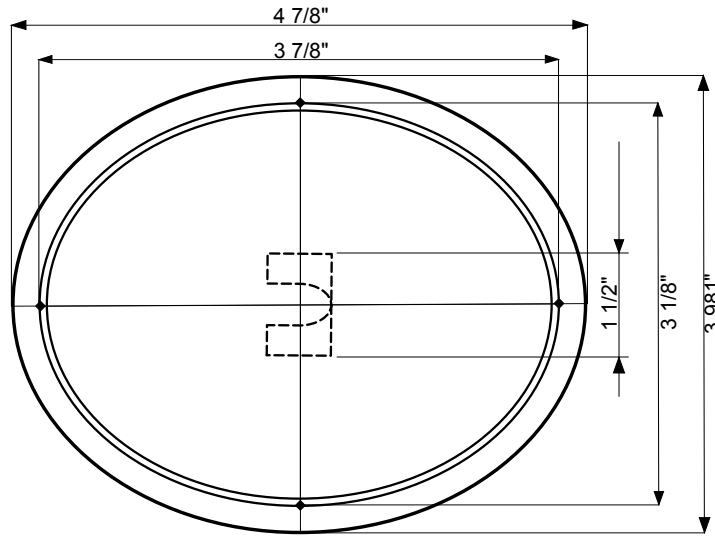

COVER
TOP VIEW

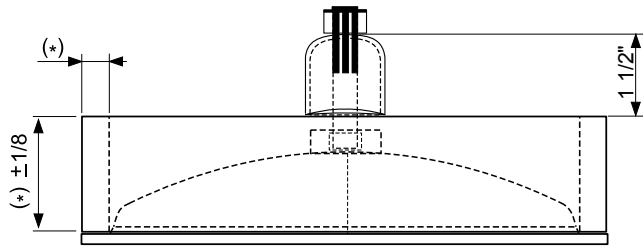

MANHOLE ASSM
FRONT VIEW

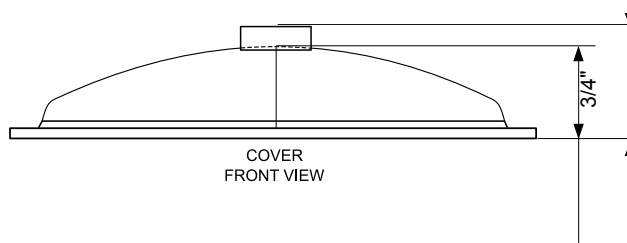

COVER
FRONT VIEW

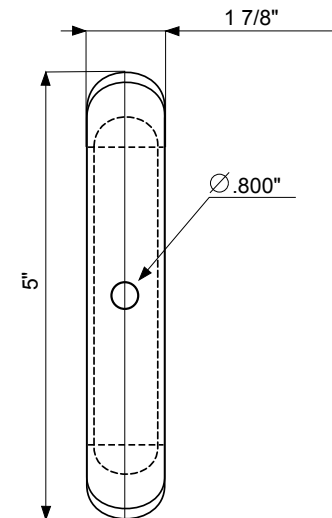
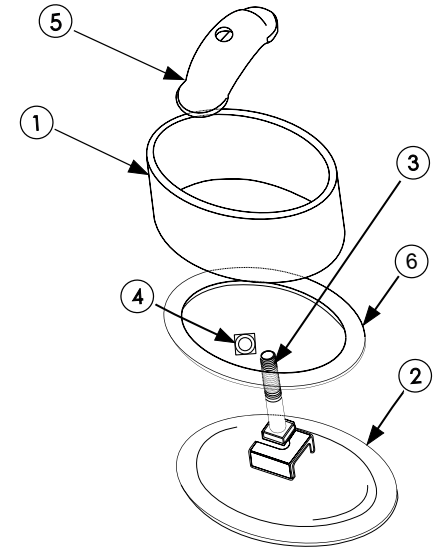

CRAB/YOKE
TOP VIEW

#	DESCRIPTION		STEEL	QTY.
1	RING	(*)	SA 106 B/C	1
2	COVER 500 psi	(*)	.250 SA-516-70	1
3	SQ BOLT	(*)	ASTM307	1
4	HSQ NUT		ASTM A563	1
5	CRAB 3X4 (CRAB/YOKE)		.188" HRC	1
6	NEOPRENE GASKET 3X4x0.1875	(*)		1

(*) OTHER GASKETS AVAILABLE

(*) OTHER RINGS AVAILABLE - SA312T-304/304L, SA312T-316/316L

(*) 1" LONGER THAN RING DEPTH

3X4 RING OPTIONS

	THICKNESS	HEIGHT
(*)	1/4"X	X1 1/2" ~ X2"
(*)	1/2"X	X1 1/2"~X2"~X3"~X4"

THESE ARE NOT PRECISION FORMED PARTS.
PLEASE ALLOW FOR NORMAL FORMING TOLERANCES.