

CG-F Series



Efficient Gas-Fired Water Boiler

- **84% AFUE**
- **38-280 MBH**
 - In 8 sizes
- **Chimney vented**
- **Integrated boiler control**
 - User-friendly
 - Energy-saving “thermal purge” feature circulates residual warm water in heating system prior to firing boiler
 - Integral LWCO (IDL-1200)
 - Additional pump relay
- **Natural or LP gas**
- **Cast iron heat exchanger**
 - Meets the ASME Boiler and Pressure Vessel Code
- **Metal section connectors**
 - Resist chemicals, increases the life of the boiler
- **Step-opening gas valve**
 - Provides smooth & quiet start-up
- **Lifetime limited warranty**
 - See your installing contractor for more warranty information



New Yorker[®]
RESIDENTIAL HEATING BOILERS

MADE IN



U . S . A .

Ratings & Specifications



MADE IN



U . S . A .

Standard Equipment

- Insulated steel jacket
- Integral draft diverter, damper and connector included
- Heavy gauge 1" base insulation
- Integrated boiler control – simple, self-diagnostic, with 3-digit readout for status
- Step-opening redundant gas valve
- 130°F minimum return temperature rating
- Spark ignition with continuous retry
- User-friendly wiring with 120V J-box
- Circulator – choice of Taco or Grundfos
- Cast iron section assembly
- Resettable blocked vent switch
- Boiler drain valve
- Cast iron supply manifold with safety relief valve tapping
- Stainless steel burners

Model	Input (MBH)	DOE Heating Capacity (MBH)	Net AHRI Rating, Water (MBH)	AFUE%
CG20F	38	32	28	84.0
CG30F	70	59	51	84.0
CG40F	105	88	77	84.0
CG50F	140	117	102	84.0
CG60F	175	146	127	84.0
CG70F	210	176	153	84.0
CG80F	245	205	178	84.0
CG90F	280	234	203	84.0

All models certified for use from sea level to 10,000 feet in elevation. Input & outputs are reduced by 4% per 1,000 feet above sea level for elevations above 2,000 ft. Boilers are shipped with 30 psi safety relief valves, MAWP is 50 psi.

Model	Dimensions (inches)						Vent Size Diameter (in.)	Approx. Shipping wt. (lbs.)	
	Width "W"	Height	Depth (total)	Supply	Return	Gas Valve			Relief Valve
CG20F	14	40	32	1-1/4	1-1/4	1/2	3/4	4	202
CG30F	14	40	32	1-1/4	1-1/4	1/2	3/4	4	254
CG40F	16	40	32	1-1/4	1-1/4	1/2	3/4	5	304
CG50F	19	40	32	1-1/4	1-1/4	1/2	3/4	6	357
CG60F	22	40	32	1-1/4	1-1/4	1/2	3/4	6	405
CG70F	25	40	32	1-1/4	1-1/4	3/4	3/4	7	462
CG80F	28	40	32	1-1/4	1-1/4	3/4	3/4	7	518
CG90F	31	40	32	1-1/4	1-1/4	3/4	3/4	8	564

NOTES:

1. Minimal radial distance around vent pipe and breaching for single-wall metal pipe vent connector, otherwise follow vent connector manufacturer's recommended clearances.
2. Add height required to maintain 6" clearance from all vent components.

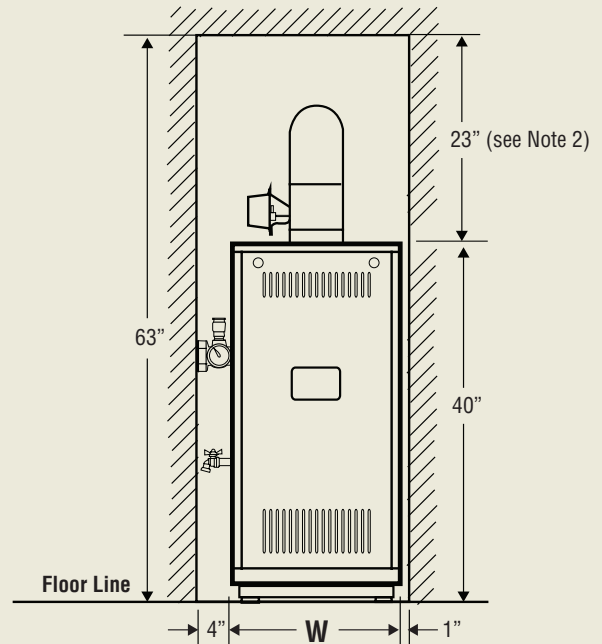
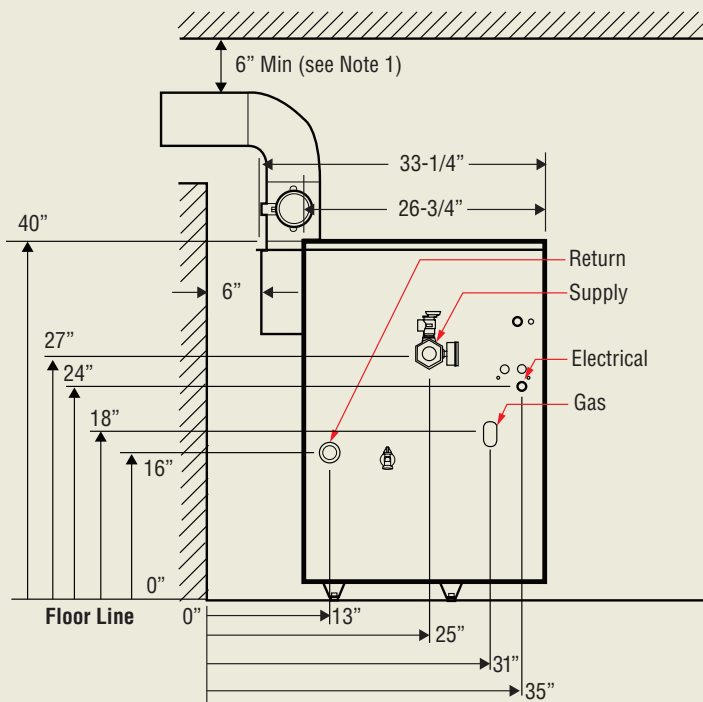

©2021 New Yorker Boiler Company, Inc., Lancaster, PA
 info@newyorkerboiler.com
 www.newyorkerboiler.com
 NYL02161-6/21 3Ms

