

3



(x1)



(x2)

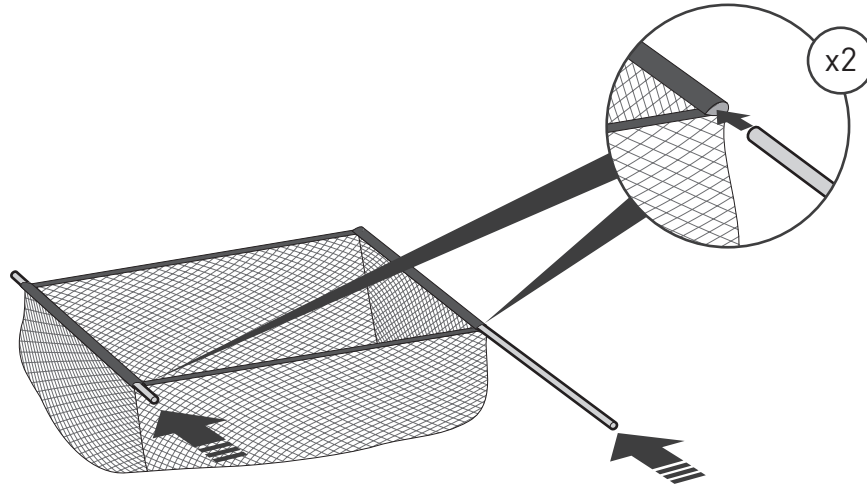

4

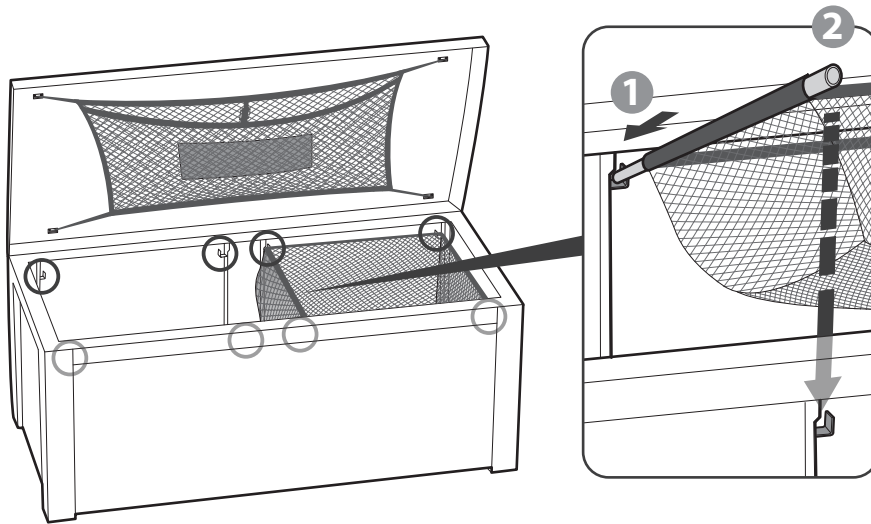

5



(x2)

