

# Sentry<sup>™</sup> Enterprise

Remote Monitoring and Control System for the Force5

User Guide

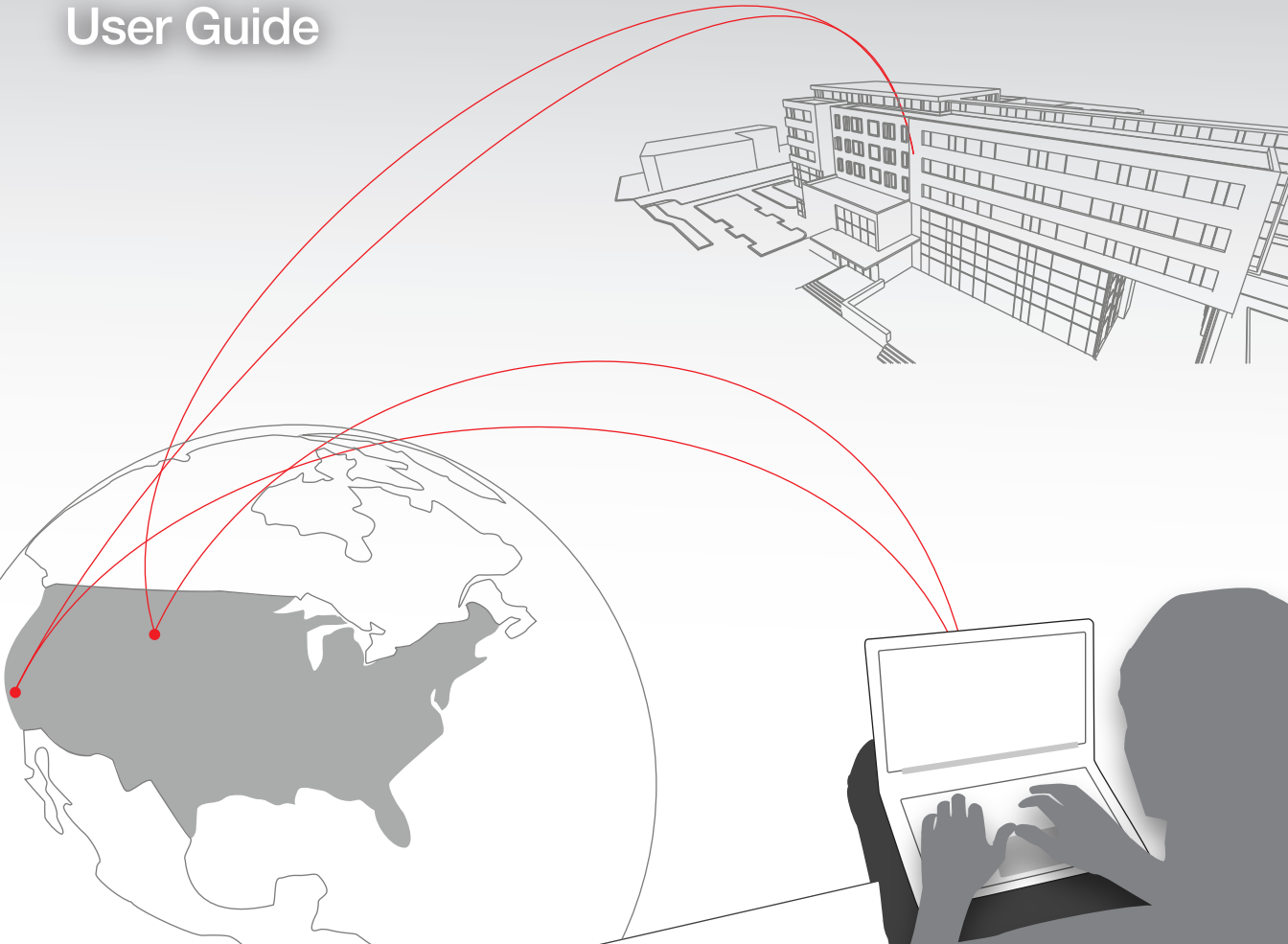



Thank you for purchasing SureCall's Sentry remote monitor and software for use with the Force5 consumer signal booster. The Sentry provides seamless installation, optimization and ongoing management of SureCall's line of boosters. If you need any assistance during installation please contact our tech support department at: 1-888-365-6283.

Package Contents	Pg. 4
Installation Overview	Pg. 5-6
Sentry Registration	Pg. 7
Adding Booster	Pg. 8-9
Antenna Placement Tool	Pg. 10-11
Configure Gain Settings	Pg. 12-13
Changing Booster Information	Pg. 14
Delete Booster	Pg. 15
Modify Password	Pg. 16
Archiving Booster Information	Pg. 17
Specifications	Pg. 18

# Package Contents

## Package Contents

Your Sentry hardware kit includes the following:

- Sentry Product
- Ribbon Cable
- USB Cable
- LAN Cable
- AC Adapter

Sentry



LAN Cable



Ribbon Cable



AC Adapter



USB Cable



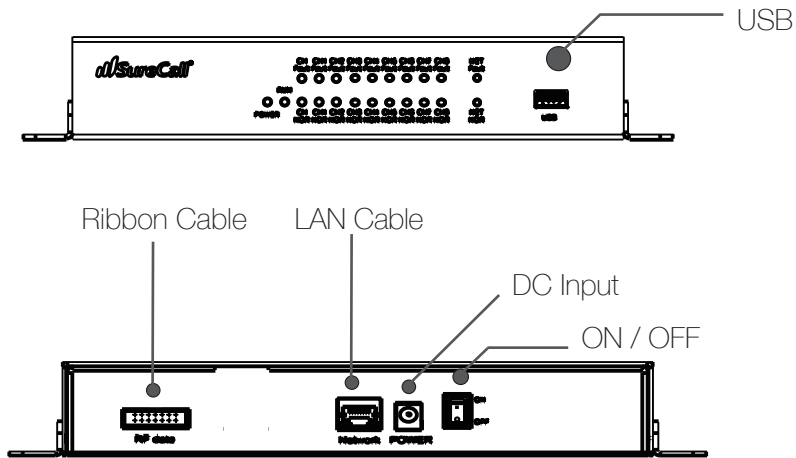

## Sentry Hardware Installation

- Step 1: Connect the ribbon cable (provided) from the Sentry's 14-Pin RF port to the booster's 14-Pin RF port.
- Step 2: Connect the USB cable (provided) to the Sentry's USB port then connect the other end of the USB cable to the USB port on your computer.
- Step 3: Connect the LAN cable to the Sentry's LAN port and connect the other end to your router.
- Step 4: Connect the AC adapter cord to the Sentry's Power port with the other end plugged into an electrical outlet.

## Sentry Software Installation

Step 1: Go to <http://www.surecall.com/product/Sentry.html>

Step 2: Register your Sentry with your customer information

Step 3: Download and save the setup application to your desktop

Step 4: Run setup file to install software

## Sentry Operation

### User Registration:



The screenshot shows a web interface for the Sentry Remote Monitoring and Control System. At the top, the title "Sentry Remote Monitoring and Control System" is displayed in blue. Below the title, there are two input fields: "Username" and "Password". To the right of the Password field is a green "Login" button. Below the input fields, there is a link "Forgot your password?". At the bottom of the form area, there are two green buttons: "Exit" and "Register". Below the buttons, the version number "(Version:V1.0)" is displayed.

Click on the Register Button

SureCall  
RAISE YOUR BARS

## Sentry Remote Monitoring and Control System

Username

Password

Forgot your password?

Server Ip

(Version:V1.0)

You will need to enter the Server IP which is 99.55.251.45. Once you have added the Server IP click the User Registration button.

### User Registration

User Name

Password

Confirm Password

E-mail

User Phone

Fill in the User Registration form and choose a user name and password. Once completed, click the Register button.

SureCall  
RAISE YOUR BARS

## Sentry Remote Monitoring and Control System

Username

Password

Forgot your password?

Login to Sentry

# Adding Booster

The screenshot shows a dialog box titled "Add Booster (one booster per Sentry)". It contains the following fields and controls:

- Com Port: A dropdown menu with "Open" and "Close" buttons.
- Server IP Address: A dropdown menu showing ". . .".
- Server Port Number: A dropdown menu.
- Auto Search IP: A checkbox.
- Sentry IP: A text input field showing ". . .".
- Sentry Subnet Mask: A text input field showing ". . .".
- Sentry Default Gateway: A text input field showing ". . .".
- Refresh: A button.
- Apply: A button.
- Sentry ID Code: A text input field.
- Booster Name: A text input field.
- Location Address: A text input field with a vertical scrollbar.
- Add: A button.

Select Com Port and Open

Click on the dropdown boxes to select the server IP address and part numbers.

Click "Refresh" to automatically assign the IP address to the Sentry.

Server IP Address will automatically enter 99.55.251.45 Click on "Apply"

Enter a Booster Name and Location Address and click on the "Add" button to add a booster



## Adding a Booster

**Add Booster (one booster per Sentry)**

Com Port: COM3 [Open] [Close]

Server IP Address: 99.55.251.45

Server Port Number: 5210

Auto Search IP

Sentry IP: 192.168.1.137

Sentry Subnet Mask: 255.255.255.0

Sentry Default Gateway: 192.168.1.254

[Refresh] [Apply]

---

Sentry ID Code: 63FF7D501465233384740234

Booster Name: Force-5

Location Address: Address

[Add]

When a booster is connected to Sentry it will automatically identify the model of the booster and show the corresponding interface.

See example next page

# Antenna Placement Tool

## Force5

Add Booster		Type: Force5 Name: Force-5 Address: Address										
Band	Channel	Attenuation	Manual Attenuation	Automatic Gain Control Attenuation	Gain	Output Power	Outside Signal Strength	Uplink/Downlink Status	Band On/Off	Over Power	Oscillation	Over Attenuation
LTE-A	Uplink 698-716M	0 dB	0 dB	0 dB	64 dB	-20 dBm		Active	ON	Normal	Normal	Normal
	Downlink 728-746M	0 dB	0 dB	0 dB	64 dB		-75 dBm	ON	ON	Normal	Normal	Normal
LTE-V	Uplink 776-792M	0 dB	0 dB	0 dB	64 dB	-20 dBm		Active	ON	Normal	Normal	Normal
	Downlink 746-757M	0 dB	0 dB	0 dB	64 dB		-75 dBm	ON	ON	Normal	Normal	Normal
Cellular	Uplink 824-849M	0 dB	0 dB	0 dB	65 dB	-15 dBm		Active	ON	Normal	Normal	Normal
	Downlink 869-894M	0 dB	0 dB	0 dB	65 dB		-75 dBm	ON	ON	Normal	Normal	Normal
PCS	Uplink 1850-1915M	0 dB	0 dB	13 dB	59 dB	-20 dBm		Active	ON	Normal	Normal	Normal
	Downlink 1930-1995M	0 dB	0 dB	4 dB	68 dB		-63 dBm	ON	ON	Normal	Normal	Normal
AWS	Uplink 1720-1755M	0 dB	0 dB	3 dB	68 dB	-17 dBm		Active	ON	Normal	Normal	Normal
	Downlink 2110-2155M	0 dB	0 dB	0 dB	71 dB		-67 dBm	ON	ON	Normal	Normal	Normal

Sentry Software Version SC ME1-MONITOR V1.6
Connection Status ● Normal

Total Data: 1    Data Sent: 1    Data Received: 1

On the main interface screen, select the booster located in the left column and click the Refresh button. This will automatically populate the fields with the booster's parameters.

## Antenna Placement Tool

This tool aids the installer in locating the best location for an outside antenna. To test for the best location, make sure the outside antenna cable is connected to the booster and outdoor antenna. Place the antenna in a position you'd like to test and click on the measure button.

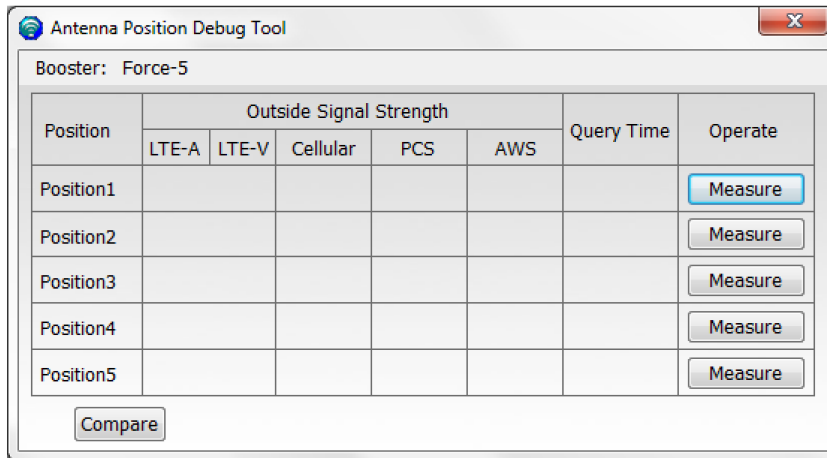

This tool will identify the optimum location for the outdoor antenna. The “Position” fields will automatically populate with the dB measurement from various locations by clicking on the measure button at each possible location. You can test up to 5 positions. Once you have entered all locations click on the “Compare” button to find the best location. Keep in mind that a signal of less than -65dB can over-power the booster. Aim for a range of -70 to -95dB. The signal strength can be adjusted to a weaker signal by:

- Moving the outside antenna to a different location
- Adding an inline attenuator to the cable connecting to the booster
- Lowering the dB gain with the dip switches on the booster or through the Attenuation column in the Sentry software

# Configure Gain Settings

Antenna Position Debug Tool

Booster: Force-5

Position	Outside Signal Strength				Query Time	Operate
	LTE-A	LTE-V	Cellular	PCS		
Position1	-56dBm	-64dBm	-44dBm	-49dBm	14:06:47	Measure
Position2	-64dBm	-69dBm	-48dBm	-51dBm	14:07:28	Measure
Position3	-66dBm	-72dBm	-53dBm	-59dBm	14:08:21	Measure
Position4	-73dBm	-75dBm	-57dBm	-65dBm	14:09:05	Measure
Position5	-75dBm	-75dBm	-63dBm	-67dBm	14:09:58	Measure

The Best Position is Position3

## Attenuation:

If the “Over Power” alert is red, the signal coming into the booster from the cellular tower is too strong which will shut down the affected band. There are three possible solutions:

1. Add an inline attenuator to the cable coming into the booster
2. Relocate the outdoor antenna to a location where the signal is weaker
3. Lower the dB gain in 5dB increments on the Sentry booster dashboard under the Attenuation column until the Over Power alert is no longer red.

# Configure Gain Settings

Tools

Add Booster

Type: Force5 Name: Force-5 Address: Address

Band	Channel	Attenuation	Manual Attenuation	Automatic Gain Control Attenuation	Gain	Output Power	Outside Signal Strength	Uplink/ Downlink Status	Band On/Off	Over Power	Oscillation	Over Attenuation
LTE-A	Uplink 698-716M	<input type="text" value="0"/> dB	<input type="text" value="30"/> dB	<input type="text" value="0"/> dB	34 dB	-20 dBm		<span style="color: yellow;">●</span> Sleep	ON ▾	<span style="color: green;">●</span> Normal	<span style="color: green;">●</span> Normal	<span style="color: green;">●</span> Normal
	Downlink 728-746M	<input type="text" value="25"/> dB	<input type="text" value="25"/> dB	<input type="text" value="0"/> dB	34 dB		-75 dBm	<span style="color: red;">●</span> OFF	ON ▾	<span style="color: green;">●</span> Normal	<span style="color: green;">●</span> Normal	<span style="color: green;">●</span> Normal
LTE-V	Uplink 776-787M	<input type="text" value="0"/> dB	<input type="text" value="30"/> dB	<input type="text" value="0"/> dB	34 dB	-20 dBm		<span style="color: yellow;">●</span> Sleep	ON ▾	<span style="color: green;">●</span> Normal	<span style="color: green;">●</span> Normal	<span style="color: green;">●</span> Normal
	Downlink 746-757M	<input type="text" value="25"/> dB	<input type="text" value="25"/> dB	<input type="text" value="0"/> dB	34 dB		-75 dBm	<span style="color: red;">●</span> OFF	ON ▾	<span style="color: green;">●</span> Normal	<span style="color: green;">●</span> Normal	<span style="color: green;">●</span> Normal
Cellular	Uplink 824-849M	<input type="text" value="0"/> dB	<input type="text" value="30"/> dB	<input type="text" value="0"/> dB	35 dB	-15 dBm		<span style="color: yellow;">●</span> Sleep	ON ▾	<span style="color: green;">●</span> Normal	<span style="color: green;">●</span> Normal	<span style="color: green;">●</span> Normal
	Downlink 869-894M	<input type="text" value="0"/> dB	<input type="text" value="25"/> dB	<input type="text" value="0"/> dB	40 dB		-75 dBm	<span style="color: red;">●</span> OFF	ON ▾	<span style="color: green;">●</span> Normal	<span style="color: green;">●</span> Normal	<span style="color: green;">●</span> Normal
PCS	Uplink 1850-1915M	<input type="text" value="0"/> dB	<input type="text" value="30"/> dB	<input type="text" value="12"/> dB	42 dB	-20 dBm		<span style="color: yellow;">●</span> Sleep	ON ▾	<span style="color: green;">●</span> Normal	<span style="color: green;">●</span> Normal	<span style="color: green;">●</span> Normal
	Downlink 1930-1995M	<input type="text" value="0"/> dB	<input type="text" value="25"/> dB	<input type="text" value="0"/> dB	47 dB		-62 dBm	<span style="color: red;">●</span> OFF	ON ▾	<span style="color: green;">●</span> Normal	<span style="color: green;">●</span> Normal	<span style="color: green;">●</span> Normal
AWS	Uplink 1710-1755M	<input type="text" value="0"/> dB	<input type="text" value="30"/> dB	<input type="text" value="2"/> dB	41 dB	-17 dBm		<span style="color: yellow;">●</span> Sleep	ON ▾	<span style="color: green;">●</span> Normal	<span style="color: green;">●</span> Normal	<span style="color: green;">●</span> Normal
	Downlink 2110-2155M	<input type="text" value="0"/> dB	<input type="text" value="25"/> dB	<input type="text" value="0"/> dB	46 dB		-69 dBm	<span style="color: red;">●</span> OFF	ON ▾	<span style="color: green;">●</span> Normal	<span style="color: green;">●</span> Normal	<span style="color: green;">●</span> Normal

Refresh Apply

Sentry Software Version SC ME1-MONITOR V1.6 Connection Status ● Alert

From the dashboard above you can manually adjust the attenuation dB to resolve problems with oscillation and overpowering. You can also turn off individual bands.

## Column Definitions:

**Attenuation:** Adjusts the amount of gain reduction.

**Manual Attenuation:** Indicates the reduced gain through the booster's dip switches.

**Automatic Gain Control:** Indicates when the booster is automatically reducing the gain due to a strong outdoor signal or close indoor/outdoor antenna proximity.

**Gain:** Indicates the current gain on the amplifier.

**Output Power:** Indicates the power output level of the booster in dBm.

**Uplink/Downlink Status:** Indicates whether a band is asleep, turned on or turned off.

Over Power, Oscillation and Over Attenuation indicate with color alerts their current status. Refer to page 11 for color definitions.

**WARNING:** Attenuation through the booster's dip switches can be lowered to a maximum of 31 dB . Through the Sentry software the maximum attenuation is 25 dB.

# Changing Booster Information

LED Color	Appearance	Indication
Red	Solid	Band is off
Red	Flashing	Signal coming into booster from cellular tower is too strong causing the booster to shut down. There are two possible solutions: 1). Add an inline attenuator to the cable coming into the booster. 2.) relocate the outdoor antenna to a location where the signal is weaker
Yellow	Flashing	Automatic Gain Control (AGC) is adjusting, part of normal operation.
Yellow	Solid	Indicates an inactive band. Light is off while band is active.
Yellow/Red	Alternately Flashing	Oscillation is detected. First try increasing the separation between the indoor and outdoor antennas. If this doesn't eliminate oscillation, lower the dB gain in 5dB increments
Green	Solid	Normal Operation

## Email Alerts

Email alerts will be sent in the event of booster overpowering or if oscillation is detected.

## Changing your Booster Information

If you wish to change your Booster information, click on Edit Booster Info within the left hand navigation

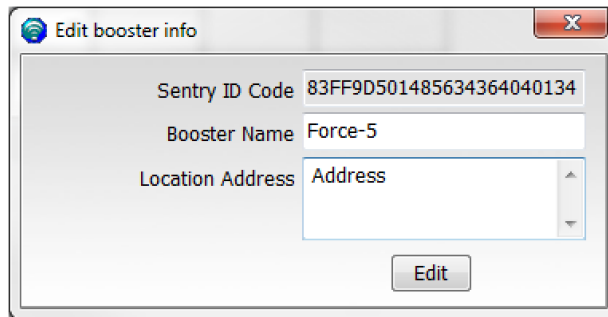
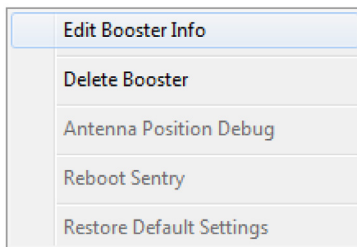

## Delete Booster

If you wish to delete a booster in order to add a new one, right click on the specific booster in the left hand navigational field first, then click on “Delete Booster” within the navigation window, click on and confirm the deletion. See below.

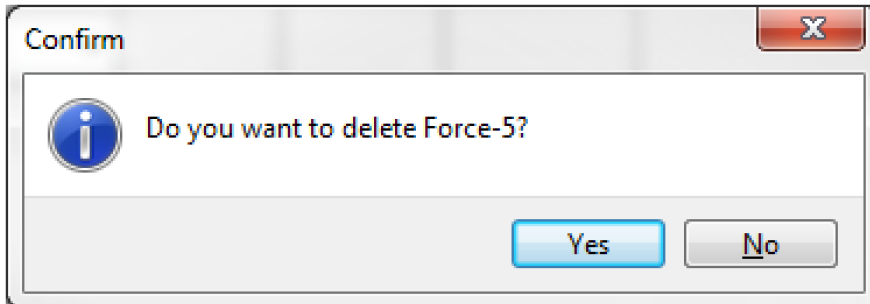
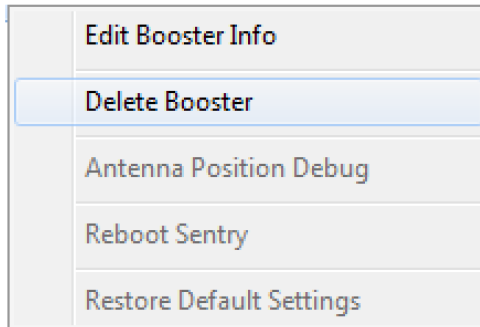

# Modify your Password

## Forget your Password?

On the login page type in the email address that you entered when you first registered and click on “Forgot your Password” your password will be emailed to you.

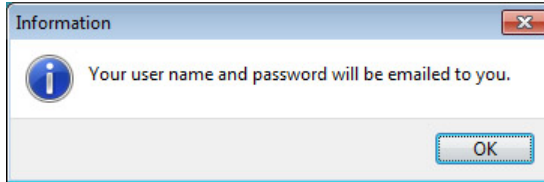

## Modifying your password:

To change your password choose Tools in the top navigation and select the Accounts menu and select Modify Password/E-mail from the drop-down menu.

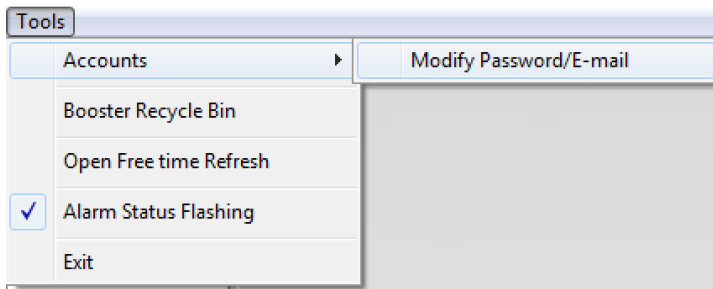

Enter the Old Password, choose a new password, confirm the new password and click on modify.

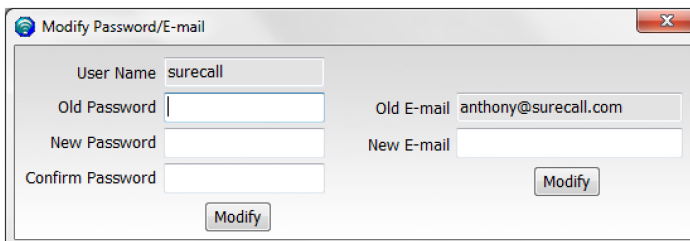
A screenshot of a "Modify Password/E-mail" dialog box. It has a title bar with a globe icon and a close button (X). The form contains the following fields:

- User Name: surecall
- Old Password: [empty text box]
- New Password: [empty text box]
- Confirm Password: [empty text box]
- Old E-mail: anthony@surecall.com
- New E-mail: [empty text box]

There are two "Modify" buttons: one at the bottom center and one at the bottom right.



## Archiving Booster Information

To temporarily change boosters, choose Tool in the top navigation and select “Booster Recycle Bin”, information for this booster will be saved. Should you like to switch back to this booster or delete it, go back to “Booster Recycle Bin” where you will be given the option to restore or delete the booster.

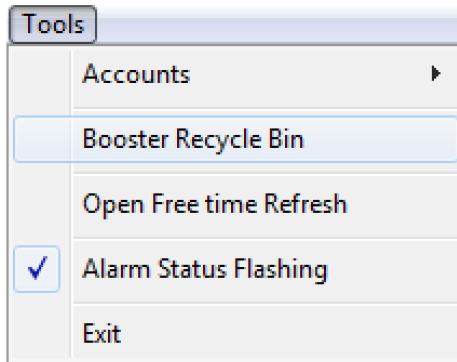

A screenshot of a window titled 'Booster Recycle Bin'. The window contains a table with four columns: 'Booster Name', 'Sentry ID Code', 'Location Address', and 'Delete Time'. The row for 'cm2020' is selected, and a context menu is open over it with 'Restore' and 'Delete' options.

Booster Name	Sentry ID Code	Location Address	Delete Time
slow to	63FF3D501465233384250234	auto	2015-02-06 09:40:10
force5 recog	63FF6D501465233394520234		2015-02-06 09:40:14
z3581	83FF8D501485634323738034	auto obtain address	2015-02-06 09:40:19
z3026	83FF9D501485634353058034	192.168.1.250	2015-02-06 09:40:24
z3582	83FF8D501485634384420134	192.168.1.230	2015-02-06 09:40:34
z1501	B30046002115431323536353	.1.200	2015-02-06 09:40:38
z0730	83FF9D501485634364040134	auto	2015-02-06 09:40:42
z0918	83FF9D501485634353443134	auto	2015-02-06 09:40:45
cm2020	63FF7D501465233384740234		2015-02-06 09:40:50

**Model No.****Sentry Enterprise (SC-Sentry-E)**

Uplink Frequency Range (MHz):	698-716 / 776-787 / 824-849 1850-1915 / 1710-1755 G Block Included
Downlink Frequency Range (MHz):	728-746 / 746-757 / 869 - 894 1930-1995 / 2110-2155 G Block Included
AC Power Transmitter:	Input AC 110 V, 60 Hz / Output DC 19 V
Dimensions:	10-1/4" X 4-1/4" X 1-5/8"
Weight:	3.8 LB



