

REVISION

ISS	ZONE	DESCRIPTION

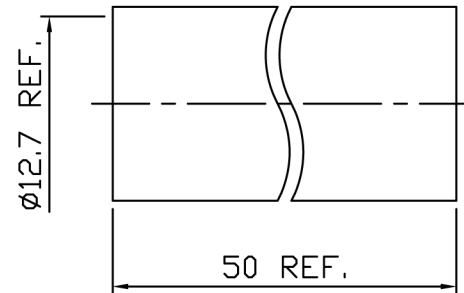
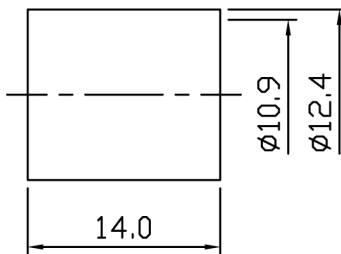
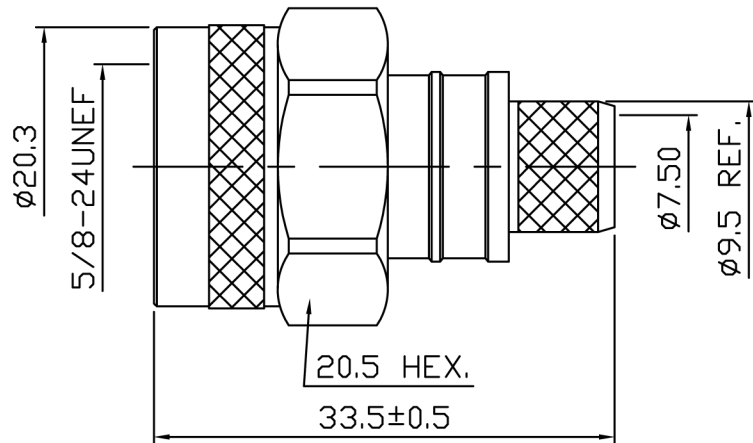

NOTE:

1. Impedance: 50Ω
2. Frequency Range: DC 0-11 GHz
3. V.S.W.R.: 1.3 MAX. @ 6GHz
4. Voltage Rating: 1500V rms
5. Contact Resistance: Center Contacts: 1.0 mΩ Max
Outer Contacts: 1.0 mΩ Max
6. Insulation Resistance: 5000 MΩ MIN.
7. Interface in Accordance With: MIL-STD 348A
8. Operating Temperature Range: -65°~165°C
9. RoHS Compliance.

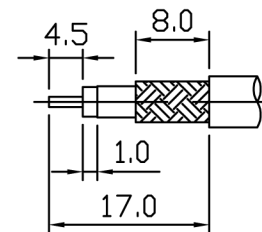

STRIPPING DIMENSION

10	HEAT TUBING	PE	BLACK	1	H-0067
9	FERRULE	BRASS	WHITE BRONZE	1	M-0275
8	BARREL	BRASS	WHITE BRONZE	1	E-0090
7	BODY	BRASS	WHITE BRONZE	1	9908094A
6	INSULATOR	TEFLON	NONE	1	T-0232
5	WASHER	BRASS	WHITE BRONZE	1	G-0019
4	CHASSIS	BRASS	WHITE BRONZE	1	E-0166
3	GASKET	SILICONE	NONE	1	R-0004
2	CENTER CONTACT	Be Cu	GOLD	1	C-0274
1	SHELL	BRASS	WHITE BRONZE	1	9908093B
NO.	DESCRIPTION	MATERIAL	FINISH	Q'TY	DRAWN NO.

TOLERANCES			
DIMENSIONS ARE IN MILLIMETER			
UNLESS OTHERWISE SPECIFIED			
.X	±0.2		
.XX	±0.1		
.XXX	±0.05		
ANGLES	±5°		

TITLE
EZ N Style Plug w/ Hex Head for TWS 400 Cable
PART NO.
CON-07-240-EZ-HEX
DRAWN NO.
FILE PATH:

TerraWave Solutions	
APPROVED	DATE
CHECKED	DATE
DRAWN	DATE