

Product size:
W155*D92*H80cm

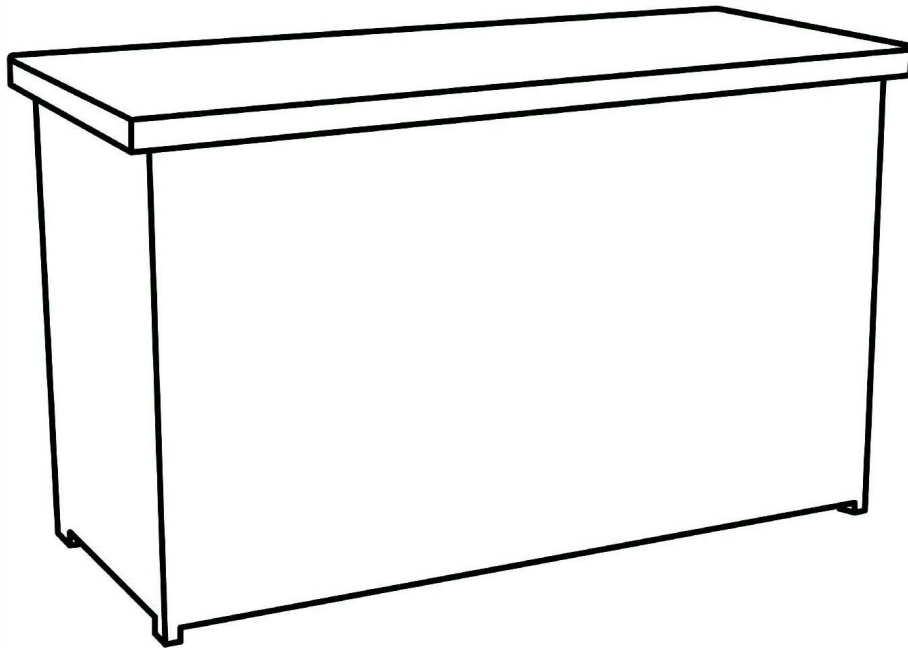

The intended use of this product is for domestic use only.

Important, please retain for future reference.

Read carefully.



Wentworth Cushion Storage Box Assembly Instructions

Before you start



Warnings

IMPORTANT, RETAIN FOR FUTURE REFERENCE READ CAREFULLY

See enclosed instructions for assembly, safety and care information.

Failure to follow the warnings could result in serious injury.

Handle heavy parts with care.

Ensure that this product is fully assembled as illustrated before use.

This product should only be used on firm, level ground.

Keep small parts out of reach of children.

Do not stand or climb onto this product.

This product is intended for **domestic use** only.

Ensure the product is always placed on level ground.

Furniture can be dangerous if incorrectly used. No liability will be accepted for damage or injury caused by incorrect use of this product.



Dos

When you are ready to start, make sure that you have the right tools, plenty of space and a clean, dry area for assembly.

Unwrap all packaging materials and place the components on a suitable surface to prevent scratching your product.

Check all contents are present prior to assembly as per the parts list provided. In the event of problems or missing parts, please contact the seller.

Check all screws and bolts are tightened and inspect regularly.

Ensure that the product is clean and dry before storage.

Clean your product with a sponge and warm soapy water then wipe with a clean, dry cloth.



Don'ts

Do not use scourers, abrasives, washing powders, chemical cleaners or any other substances containing abrasives since these substances can damage the product.

Never use the cushion box as a bench.

Do not use this product if parts are missing, damaged or worn.

Do not stand or climb onto the product and do not use it as a ladder, as this could lead to it unbalancing and overturning.

Never drag furniture when moving it, always lift it.

Children are not allowed to use this Cushion Box alone unless there is adult at present.

Number of people required for assembly

Two people

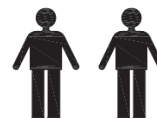

Time to assemble



50 Minutes

Tools required

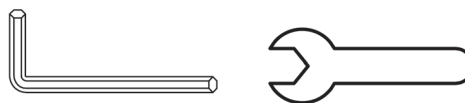

Tips:

Do NOT fully tighten bolts before all components are connected.



Only fully tighten once you are satisfied with the alignment of all components.

Do not overtighten the bolts.

www.royalcraft.co.uk

Wentworth Cushion Storage Box Assembly Instructions

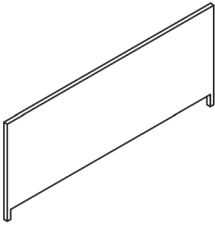
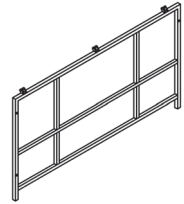
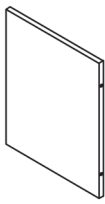
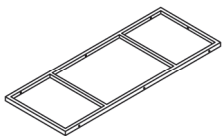
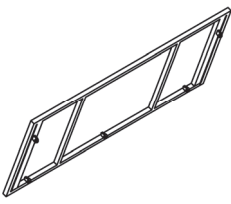
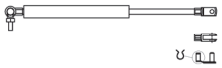
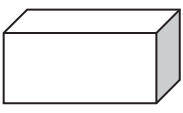

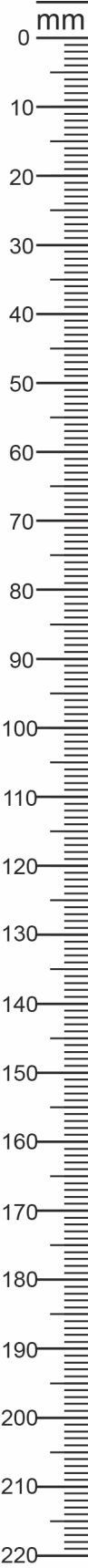

Components, fixtures & fittings (not actual size)

Parts List					
Part No.	Diagram	Qty.	Part No.	Diagram	Qty.
A	 Front Panel	1 PC	B	 Back Panel	1 PC
C	 Side Panel	2 PCS	D	 Bottom Panel	1 PC
E	 Lid	1 PC	F	 Pump	2 PCS
G	 Lining	1 PC	H	 Washer	24 PCS



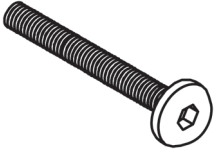
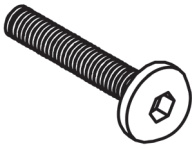

Wentworth Cushion Storage Box Assembly Instructions

I	 Bolt Head Cap	21 PCS	J	 Nut	3 PCS
K	 M6*45mm	18 PCS	L	 M6*35mm	3 PCS
M	 Allen Key	1 PC	N	 Spanner	1 PC

Step by step assembly instructions

Step One

Assemble the Front Panel (A) and Back Panel (B) to the Side Panels (C) using Washers (H), Bolts (K) and Bolt Head Caps (I).

NOTE:

Do not fully tighten any of the bolts until all bolts are in place and aligned.

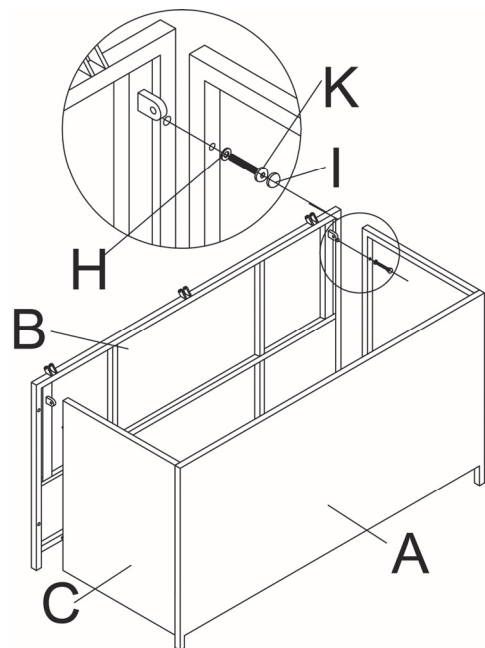

www.royalcraft.co.uk

Wentworth Cushion Storage Box Assembly Instructions

Step Two

With the help of another person, turn over the partly-assembled box, assemble the Bottom Panel (D) to all adjacent panels (A, B, C) using Washers (H), Bolts (K) and Bolt Head Caps (I).

With the help of another person, Carefully place it in the upright position.

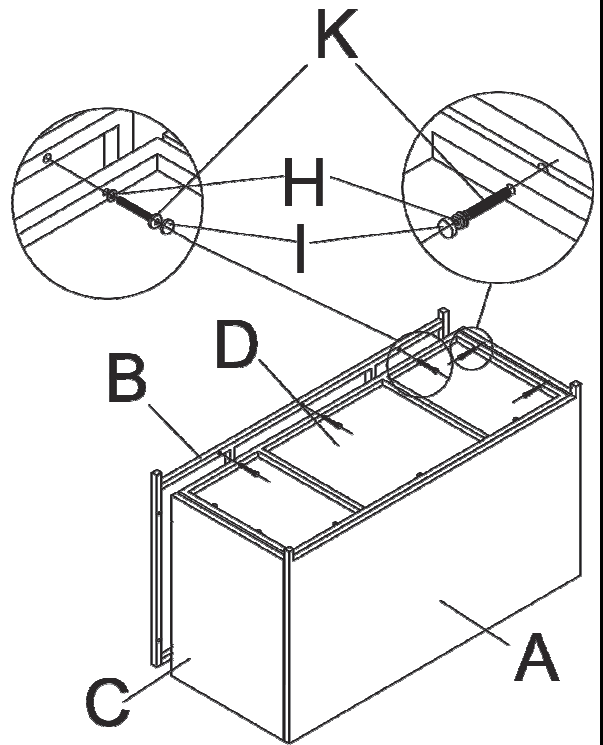

Step Three

With the help of another person, assemble the Lid (E) to the Back Panel (B) using Washers (H), Bolts (L), Nuts (J) and Bolt Head Caps (I).

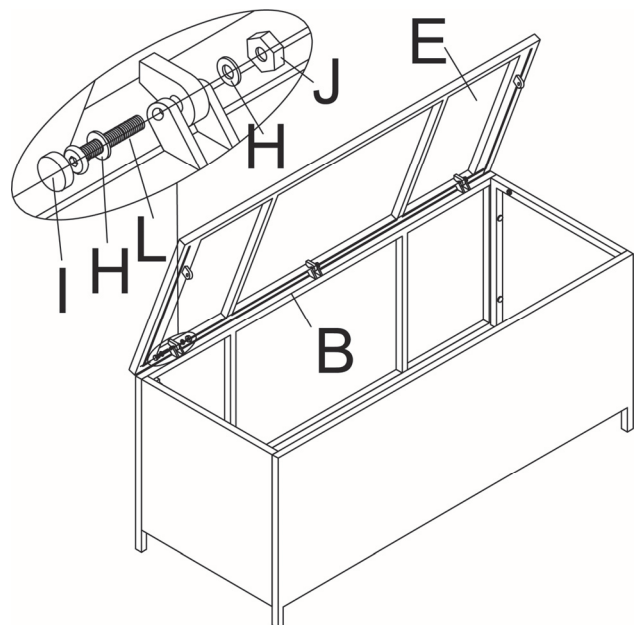

Step Four

Assemble the Pumps (F) to the Side Panels (C) and Lid (E).

Attach the Lining (G) to the Cushion Box.

Your Cushion Box is now ready for use.

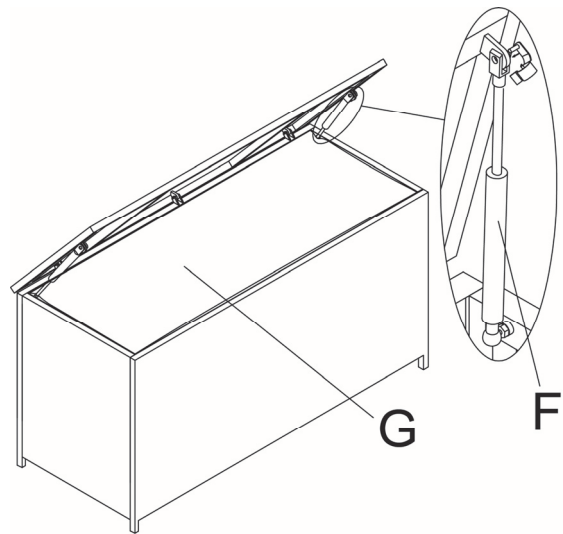

Be careful and don't pinch your fingers.

Always be careful when close the lid.

Drop down the lid slowly.

Children and Kids should NOT use this box.

PLEASE KEEP THESE INSTRUCTIONS FOR FUTURE REFERENCE