

Product size:

LH SOFA: W151\*D80\*H76.5 CM X 1

RH SOFA: W151\*D80\*H76.5 CM X 1

BENCH: W110\*D40\*H34.5 CM X 2

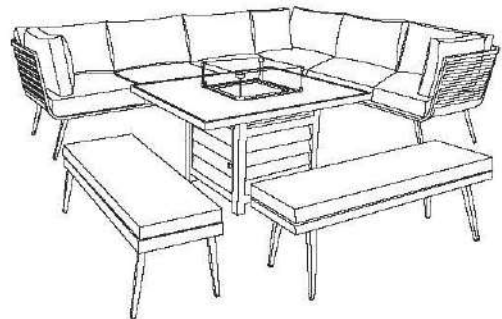
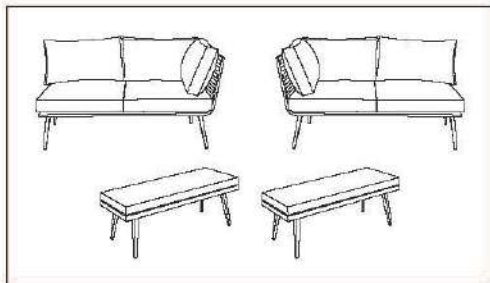

Furniture should be covered/stored whilst not in use to prolong its longevity.  
(It should also be covered in adverse weather.)

The intended use of this product is for domestic use only.

Important, please retain for future reference.

Read carefully.

### Before you start



#### Warnings

##### **IMPORTANT, RETAIN FOR FUTURE REFERENCE READ CAREFULLY**

See enclosed instructions for assembly, safety and care information.

Failure to follow the warnings could result in serious injury.

Handle heavy parts with care.

Ensure that this product is fully assembled as illustrated before use.

This product should only be used on firm, level ground.

**The product contains small parts which could pose a risk to young children. Keep small parts out of reach of children.**

This product is intended for **domestic use** only.

Ensure the product is always placed on level ground.

Furniture can be dangerous if incorrectly used. No liability will be accepted for damage or injury caused by incorrect use of this product.

#### ✓ Dos

When you are ready to start, make sure that you have the right tools, plenty of space and a clean, dry area for assembly.

Remove all packaging and banding and place the components carefully on suitable surfaces to prevent damaging or scratching them.

Check the pack and make sure you have all of the parts listed.

Check all screws and bolts are tightened and inspect regularly.

During severe weather conditions, including high winds, rain, hail, thunderstorms, extreme heat and cold temperatures, the product should be stored inside in a cool, dry place.

To best preserve this product, please use a protective cover when your furniture is not in use. We would also recommend using a gazebo or parasol over your furniture during the summer period and prolonged sunny spells. This will help prevent harmful UV rays from damaging and discolouring the material.

Any scratches on the paintwork should be touched up immediately with metal paint to prevent corrosion.

Ensure that the product is clean and dry before storage.

Clean your product with a sponge and warm soapy water then wipe with a clean, dry cloth.

Where instructions as to the; storage, commissioning, installation, use and maintenance of the goods or (if there is none) good trade practice are not followed and a defect arises this will void the 12 month manufacturer's guarantee on the product.

Cushions should be cleaned following the care instruction on the label.

If the set is stored outside then we recommend that cushions are brought inside for storage and protection.

#### ✗ Don'ts

Do not use scourers, abrasives, washing powders, chemical cleaners or any other substances containing abrasives since these substances can damage the product, including the glass panel.

Never tilt the product during use.

Do not strike the product with hard or pointed items.

Do not use power tools to construct this product.

Do not use this product if parts are missing, damaged or worn.

Do not stand or climb onto the product and do not use it as a ladder, as this could lead to it unbalancing and overturning.

Never drag furniture when moving it, always lift it.

#### Number of people required for assembly

Two people



#### Time to assemble

30 minutes

#### Tools required



#### Tips:

**Do NOT fully tighten bolts before all components are connected. Only fully tighten once you are satisfied with the alignment of all components. Do not overtighten bolts.**

### Member Parts

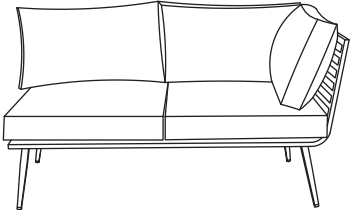
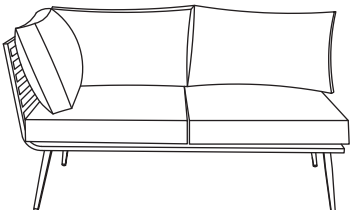
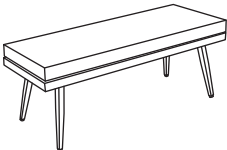
| Part No. | Diagram   | Name    | Qty.  |
|----------|---|---------|-------|
| 1        |    | LH SOFA | 1 PC  |
| 2        |    | RH SOFA | 1 PC  |
| 3        |  | BENCH   | 2 PCS |

## Velcro Band Assembly

In order to better use the products, the sofa parts are suggested to be connected by Velcro Band with other parts (in other cartons).

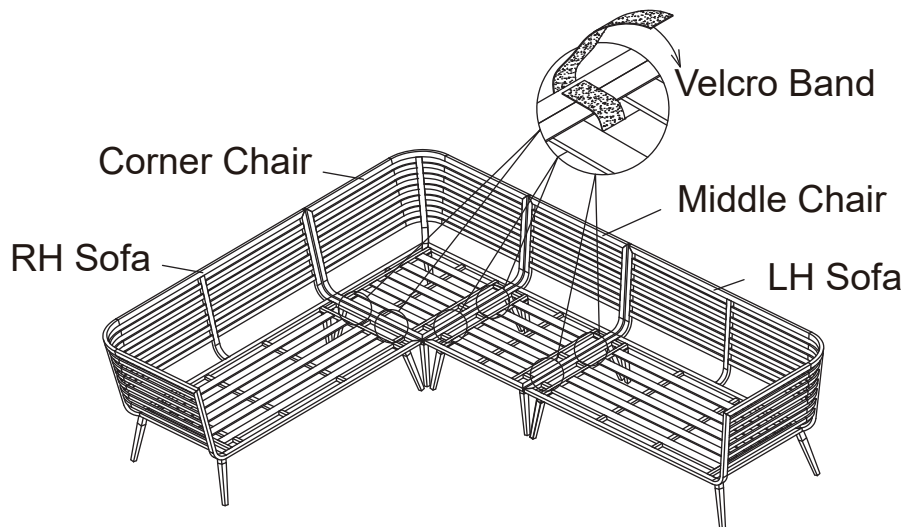

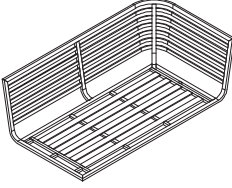
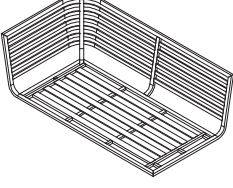
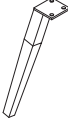
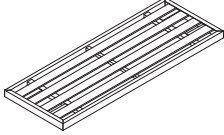
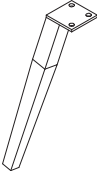
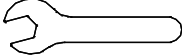
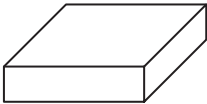
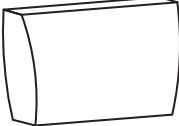
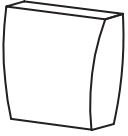
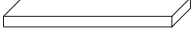

### Components, fixtures & fittings (not actual size)

#### Parts List

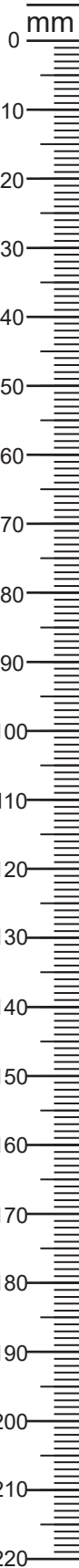
| Part No. | Diagram   | Qty.  | Part No. | Diagram  | Qty.  |
|----------|---|-------|----------|--|-------|
| A        | <br>LH Sofa Seat                     | 1 PC  | B        | <br>RH Sofa Seat             | 1 PC  |
| C        | <br>Sofa Leg<br>30*30*1.6T*H278mm    | 8 PCS | D        | <br>Bench Seat             | 2 PCS |
| E        | <br>Bench Leg<br>30*30*1.6T*H320mm | 8 PCS | S1       | <br>Spanner               | 1 PC  |
| F        | <br>Sofa Seat Cushion              | 4 PCS | G        | <br>Sofa Backrest Cushion | 4 PCS |
| H        | <br>Sofa Side Cushion              | 2 PCS | I        | <br>Bench Seat Cushion     | 2 PCS |

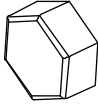
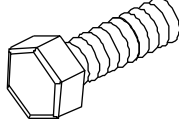

|    |  |        |     |   |           |
|----|--|--------|-----|---|-----------|
| F2 | <br>Bolt Head Cap | 48 PCS | W20 | <br>M6*20mm Bolt | 48<br>PCS |
| F3 | <br>Flat Washer   | 48 PCS |     |   |           |

### Step by step assembly instructions

### Part 1: LH Sofa

#### Step One

Open the packaging, with the help of another person, place the LH Sofa Seat (A) upside down on a flat, non-abrasive surface to avoid scratching the surface or rim.

Loosely attach the Legs (C) onto the LH Sofa Seat (A) using Flat Washers (F3), Bolts (W20) and Bolt Head Caps (F2).

Only tighten the bolts when all bolts and washers are in place and turn freely. Once you are satisfied with the alignment of the components carefully tighten all bolts using Spanner (S1). Do not over-tighten. Cover each bolt with Bolt Head Cap (F2).

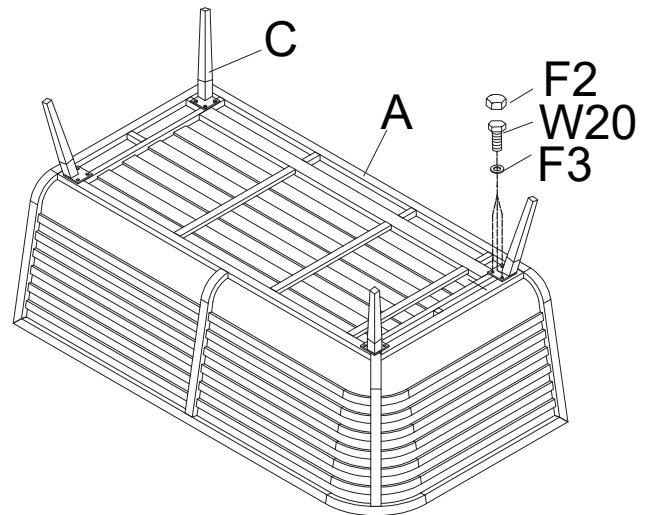

### Step Two

With the help of another person, stand the Sofa.

Level it by adjustable feet screws.

Place the Sofa Seat Cushion (F), Sofa Backrest Cushions (G) and Sofa Side Cushion (H) onto the Sofa Seat (A).

Your LH Sofa is now ready for use.

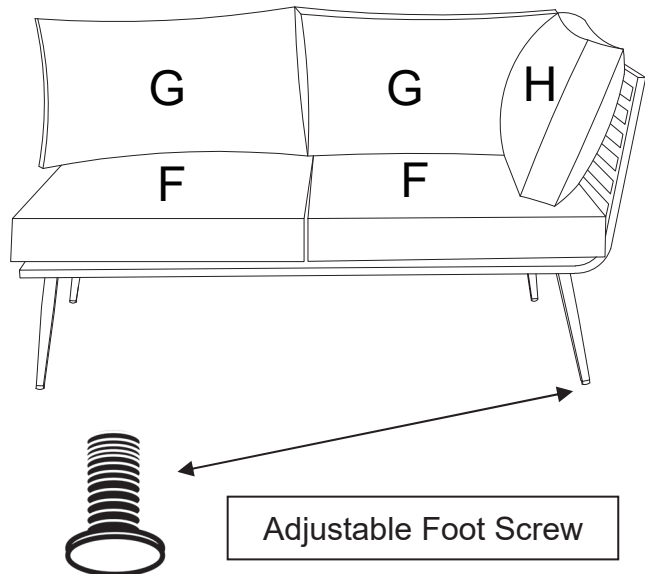

### Part 2: RH Sofa

#### Step One

Open the packaging, with the help of another person, place the RH Sofa Seat (B) upside down on a flat, non-abrasive surface to avoid scratching the surface or rim.

Loosely attach the Legs (C) onto the RH Sofa Seat (B) using Flat Washers (F3), Bolts (W20) and Bolt Head Caps (F2).

Only tighten the bolts when all bolts and washers are in place and turn freely. Once you are satisfied with the alignment of the components carefully tighten all bolts using Spanner (S1). Do not over-tighten. Cover each bolt with Bolt Head Cap (F2).

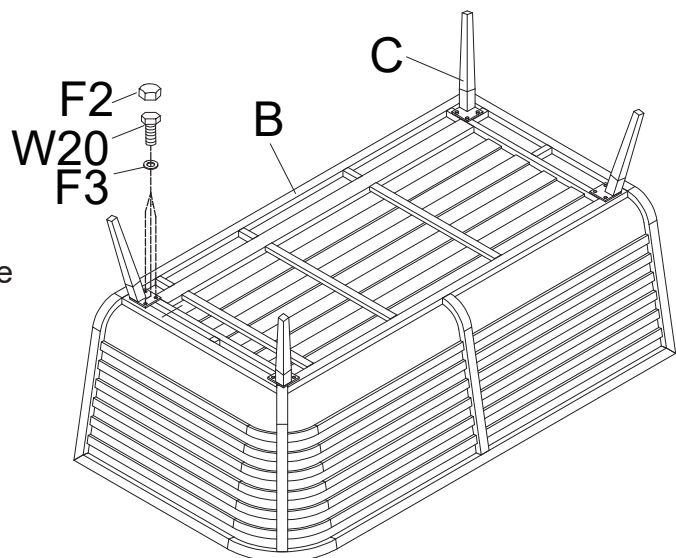

### Step Two

With the help of another person, stand the Sofa.

Level it by adjustable feet screws.

Place the Sofa Seat Cushion (F), Sofa Backrest Cushions (G) and Sofa Side Cushion (H) onto the Sofa Seat (B).

Your RH Sofa is now ready for use.

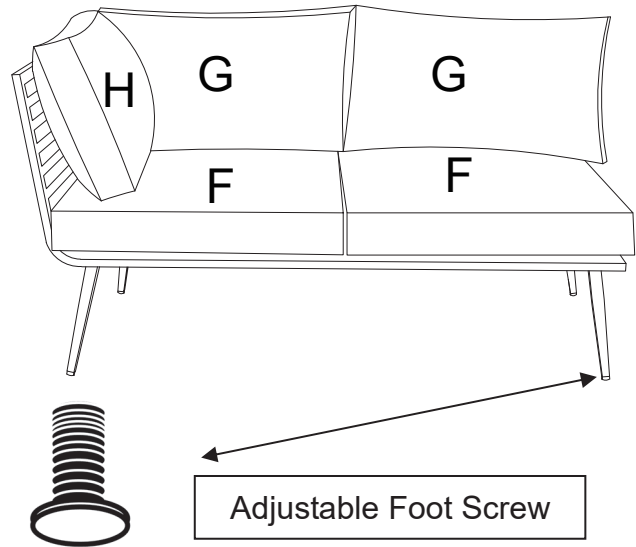

### Part 3: Bench

#### Step One

Open the packaging, with the help of another person, place the Bench Seat (D) upside down on a flat, non-abrasive surface to avoid scratching the surface or rim.

Loosely attach the Legs (E) onto the Bench Seat (D) using Flat Washers (F3), Bolts (W20) and Bolt Head Caps (F2).

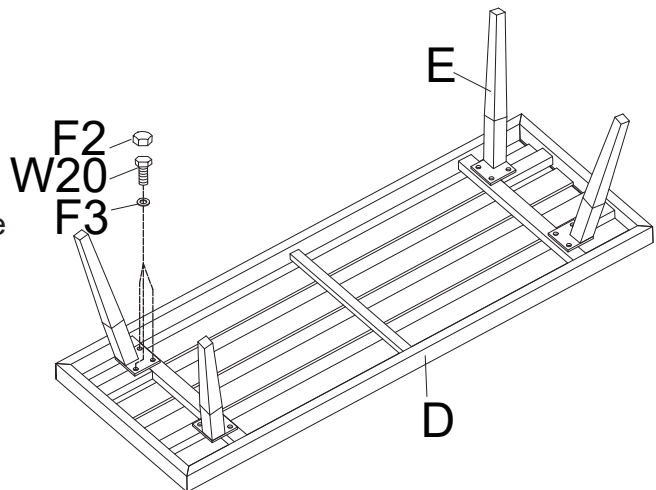

Only tighten the bolts when all bolts and washers are in place and turn freely. Once you are satisfied with the alignment of the components carefully tighten all bolts using Spanner (S1). Do not over-tighten. Cover each bolt with Bolt Head Cap (F2).

### Step Two

With the help of another person, stand the Bench.

Level it by adjustable feet screws.

Place the Bench Seat Cushion (I) onto the Bench Seat (D).

Your Bench is now ready for use.

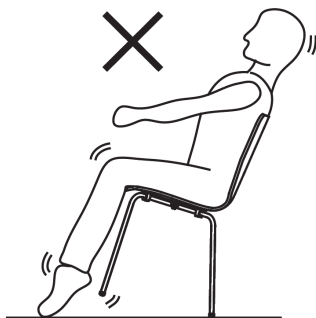
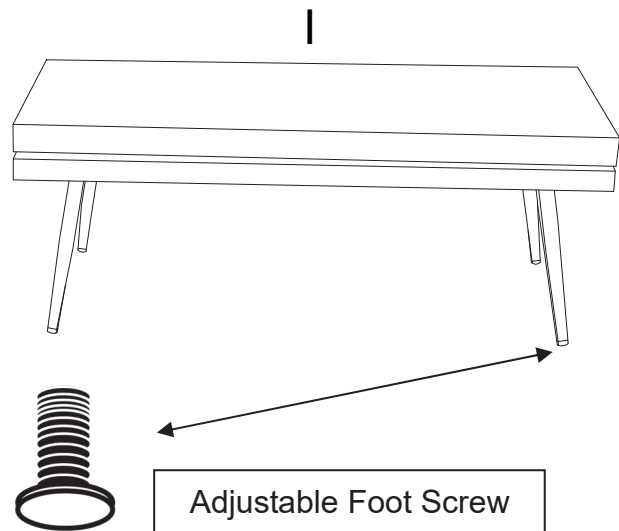

Never tilt the products during use.  
Ensure the product is always placed firmly on the ground.

**PLEASE KEEP THESE INSTRUCTIONS FOR FUTURE REFERENCE**

**RE REFERENCE**