

Product size: W14.3\*D65.8\*H89.8 cm

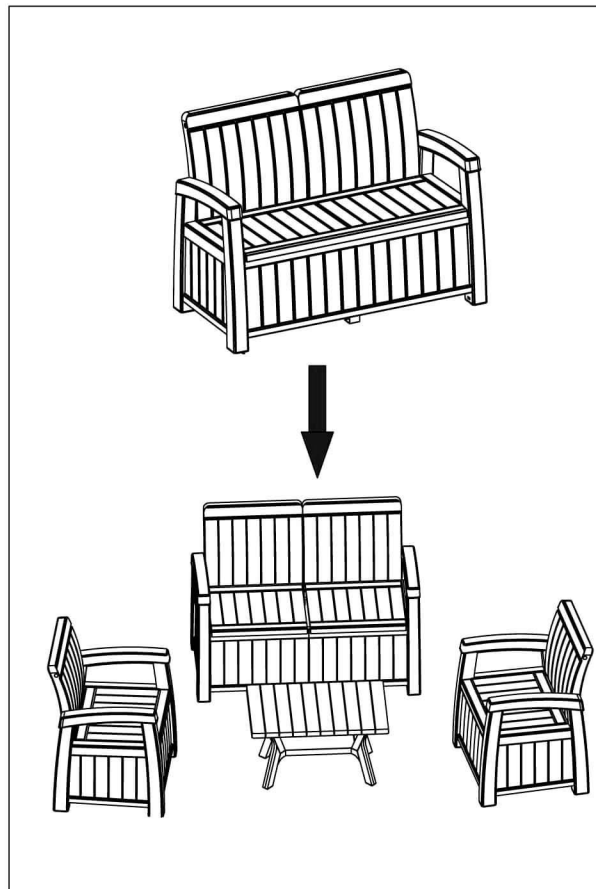

An environment-friendly product made of polypropylene  
which can be recyclable after end of use.

The intended use of this product is for domestic use only.

Important, please retain for future reference.

Read carefully.

# Faro 4pcs Conversation Set - 2 Seater Sofa with Storage Facility Assembly Instructions

## Before you start

### Warnings

#### IMPORTANT, RETAIN FOR FUTURE REFERENCE READ CAREFULLY

See enclosed instructions for assembly, safety and care information.

Failure to follow the warnings could result in serious injury.

Handle heavy parts with care.

Ensure that this product is fully assembled as illustrated before use.

This product should only be used on firm, level ground.

**Keep small parts out of reach of children.**

This product is intended for **domestic use** only.

Ensure the product is always placed on level ground.

Furniture can be dangerous if incorrectly used. No liability will be accepted for damage or injury caused by incorrect use of this product.

### Dos

When you are ready to start, make sure that you have the right tools, plenty of space and a clean, dry area for assembly.

Unwrap all packaging materials and place the components on a suitable surface to prevent scratching your product.

Check all contents are present prior to assembly as per the parts list provided. In the event of problems or missing parts, please contact the seller.

Check all screws and bolts are tightened and inspect regularly.

Cover furniture when not in use to add additional protection to your product.

During severe weather conditions, including high winds, rain, hail, thunderstorms, extreme heat and cold temperatures, the product should be stored inside in a cool, dry place.

To best preserve this product, please use a protective cover when your furniture is not in use. This will help prevent harmful UV rays from damaging and discolouring the material.

Ensure that the product is clean and dry before storage.

Clean your product with a sponge and warm soapy water then wipe with a clean, dry cloth.

### Don'ts

Do not use scourers, abrasives, washing powders, chemical cleaners or any other substances containing abrasives since these substances can damage the product.

To preserve the table top design do not place greasy / oily items directly onto the surface. Use place-mats to prevent spillages of food or drink.

Do not place very hot or very cold items on the surface unless adequately thick table-mats are used to prevent such items from coming into contact with the product.

Do not use power tools to construct this product.

Do not use this product if parts are missing, damaged or worn.

Do not stand or climb onto the product and do not use it as a ladder, as this could lead to it unbalancing and overturning.

Never drag furniture when moving it, always lift it.

### Number of people required for assembly

Two people

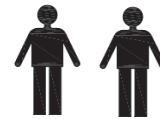

### Time to assemble

30 Minutes

### Tools required

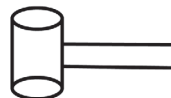

(Rubber Hammer may be required, not provided)

# Faro 4pcs Conversation Set - 2 Seater Sofa with Storage Facility Assembly Instructions

Components, fixtures & fittings (not actual size)

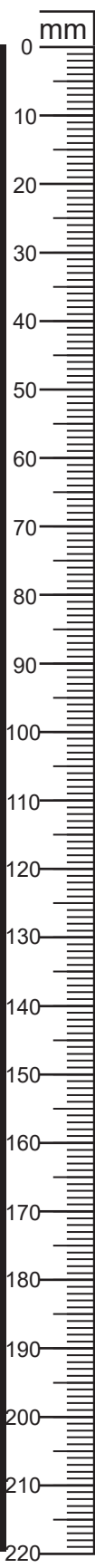



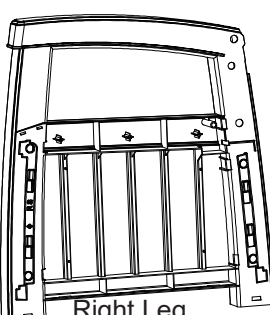
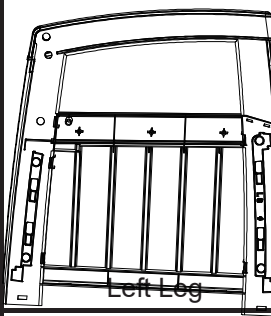
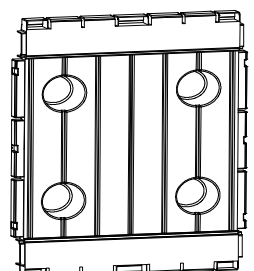
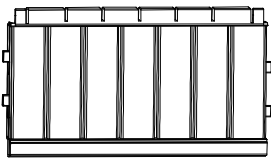
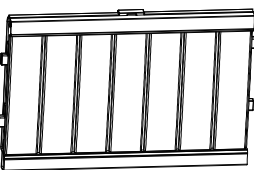
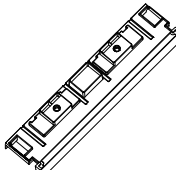
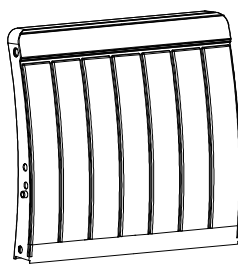
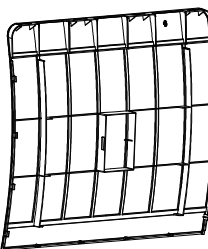

## Parts List

Part No.	Diagram	Qty.	Part No.	Diagram	Qty.
RS	 Right Leg	1 PC	LS	 Left Leg	1 PC
D	 Box Bottom Panel	2 PCS	R	 Box Rear Panel	2 PCS
F	 Box Front Panel	2 PCS	H	 Connecting Bar for Backrest	2 PCS
BC	 Front Panel for Backrest	2 PCS	B	 Rear Panel for Backrest	2 PCS

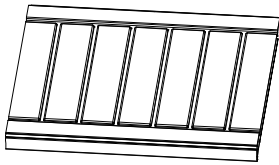
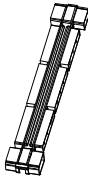
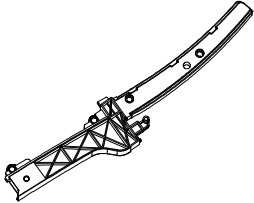
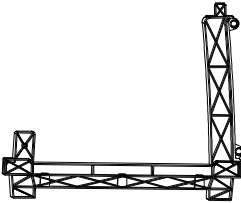
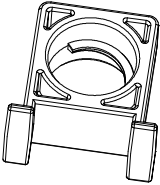
[www.royalcraft.co.uk](http://www.royalcraft.co.uk)

## Faro 4pcs Conversation Set - 2 Seater Sofa with Storage Facility Assembly Instructions

I	 Seat Panel	2 PCS	ML3	 Connecting Bar for Seat Panel	1 PC
ML2	 Middle Leg Backrest Pole	1 PC	ML1	 Middle Leg	1 PC
M	 Nut	1 PC	N	 Bolt	23 PCS
O	 Cap	2 PCS	P	 Spanner	1 PC

### Step by step assembly instructions

### Step One

Attach Part (ML2) to Part (ML1).

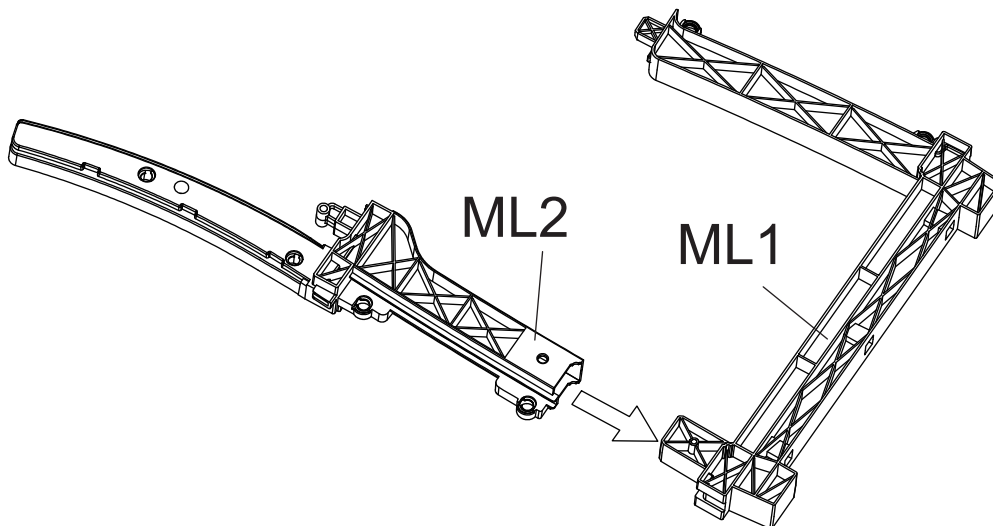

### Step Two

Attach the Box Bottom Panels (D) to the Part (ML2) & (ML1).

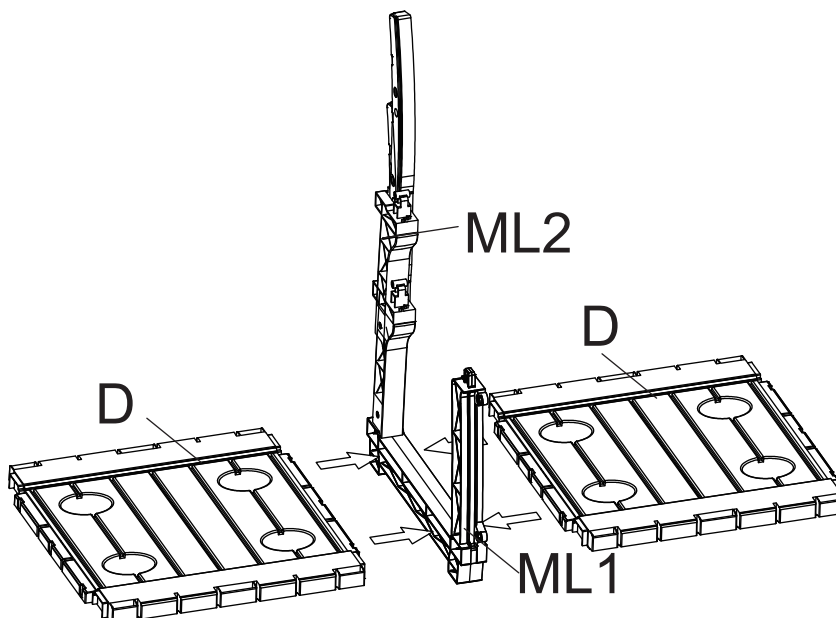

## Step Three

Attach Box Rear Panel (R) to each other.

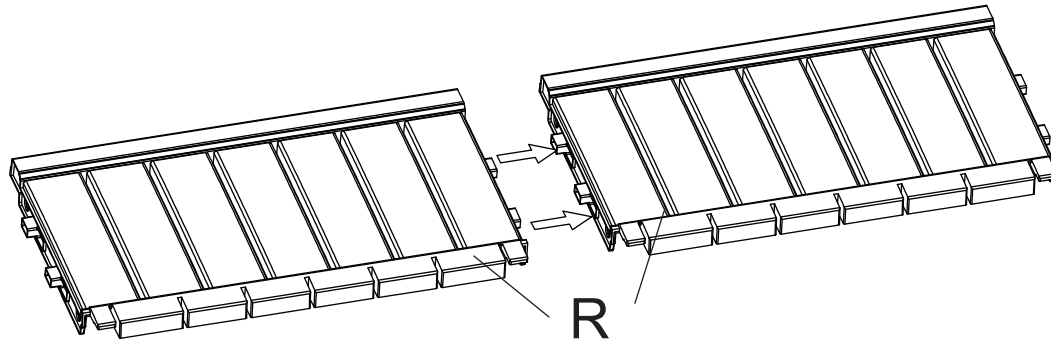

## Step Four

Attach Box Rear Panel (R) to the Part (ML2) and (ML1) using Bolts (N).  
2 Bolts are used in this Step.

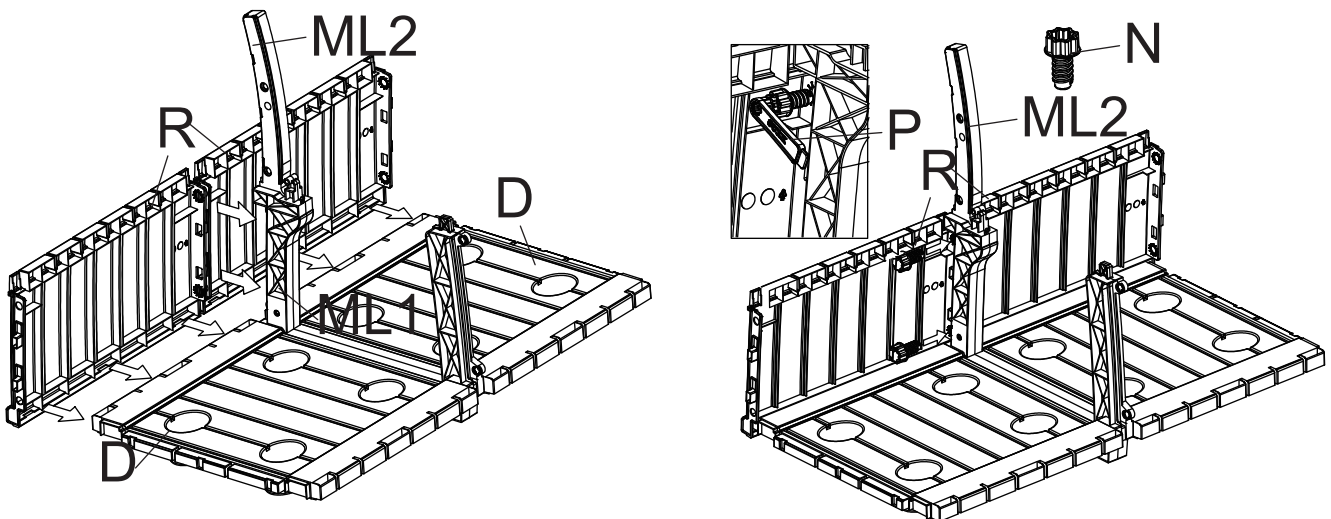

## Step Five

Attach Box Front Panel (F) to each other.

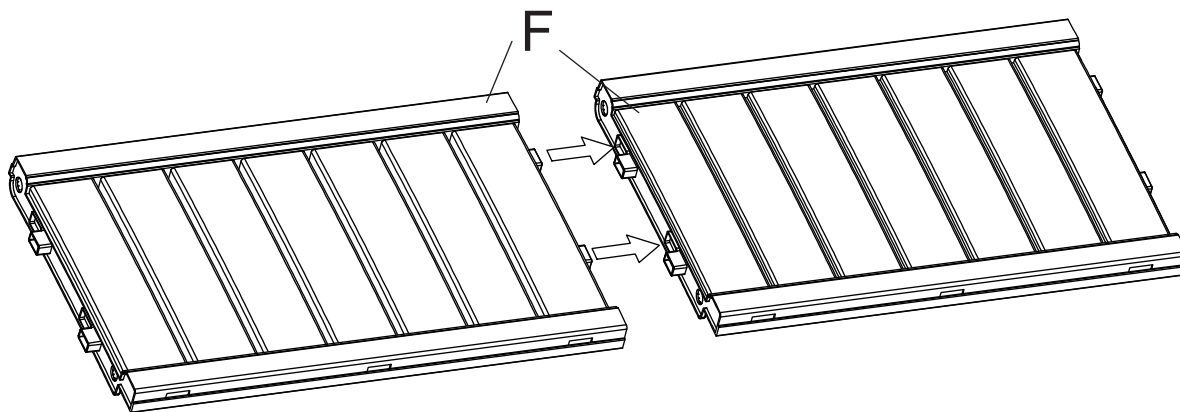

## Step Six

Attach Box Front Panel (F) to the Part (ML1) and (D) using Bolts (N).  
2 Bolts are used in this Step.

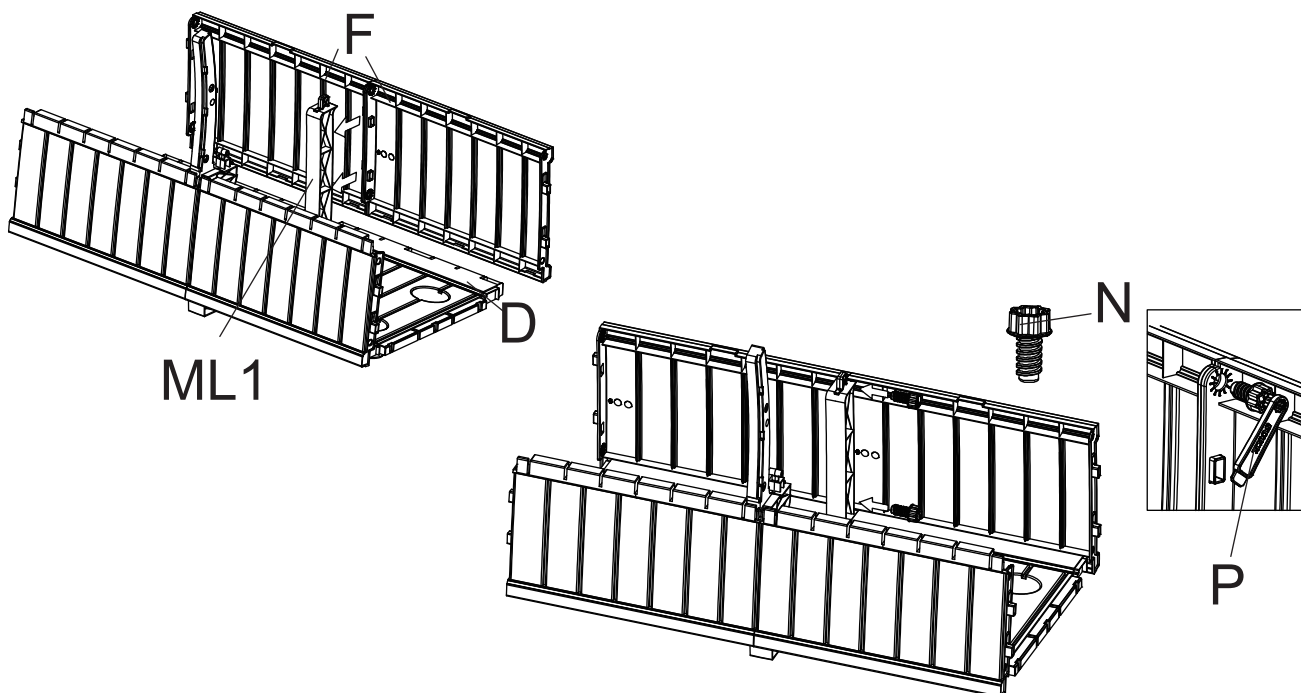

## Step Seven

Attach Connecting Bar for Backrest (H) to the assembled Parts.

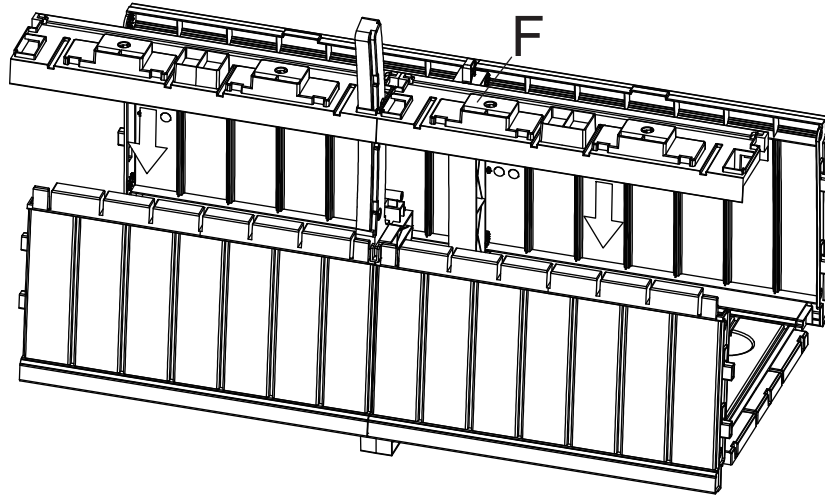

## Step Eight

Attach Front Panel for Backrest (BC) to the assembled Parts using Nut (M) and Bolts (N).  
7 Bolts are used in this Step.

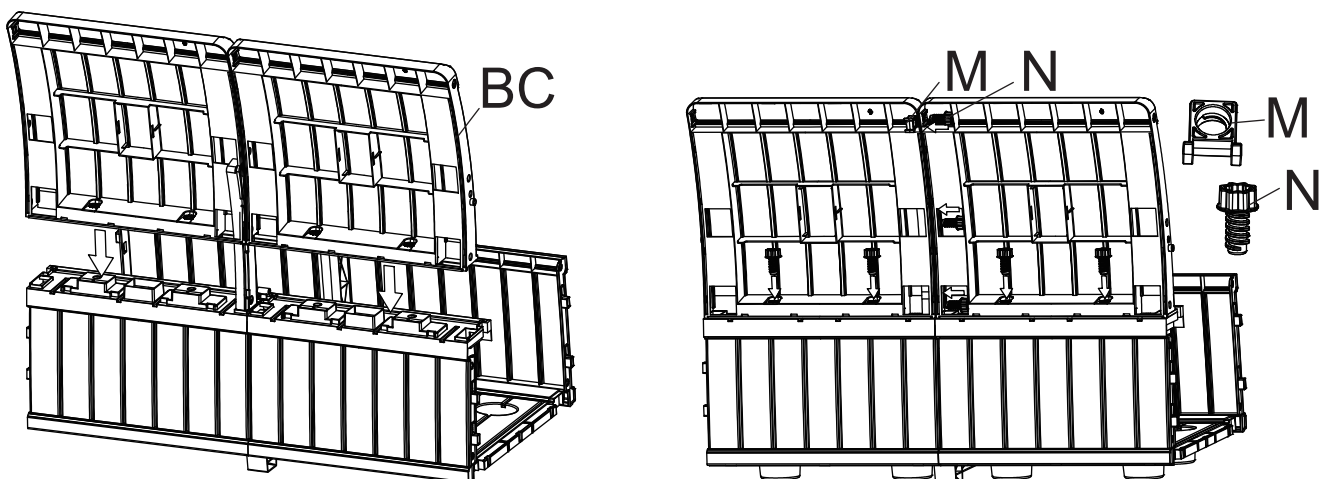



### Step Nine

Attach Right Leg (RS) to the assembled Parts using Bolts (N).  
Attach Left Leg (LS) to the assembled Parts using Bolts (N).

12 Bolts are used in this Step.

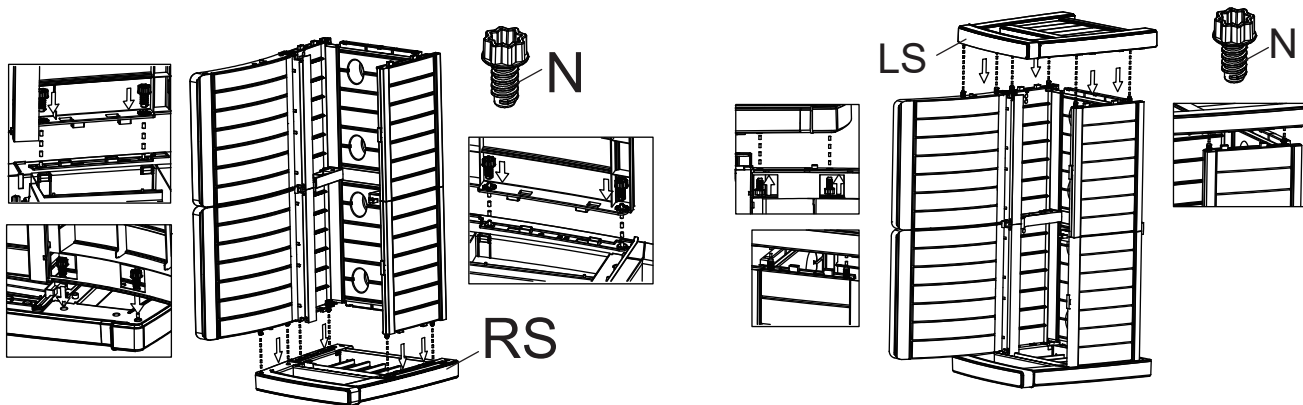

### Step Ten

Attach Rear Panel for the Backrest (B) to the assembled Parts.

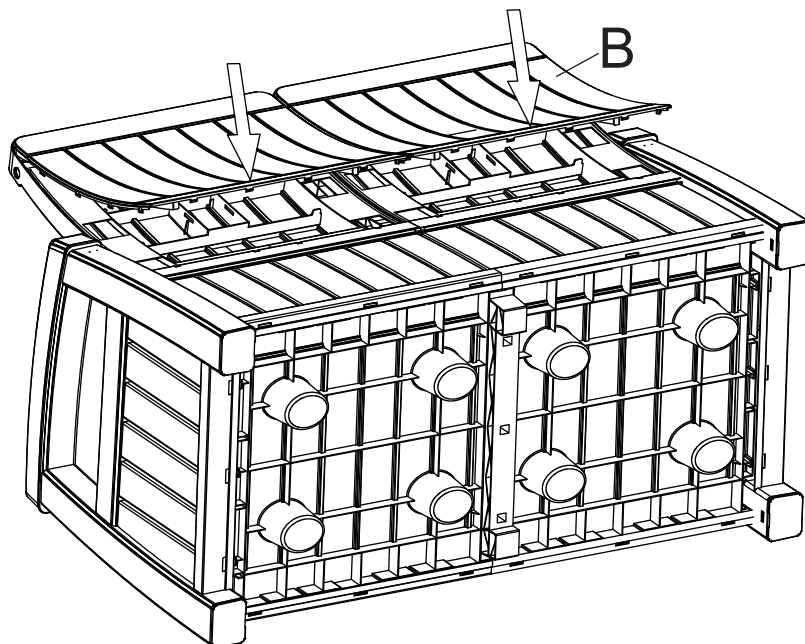

### Step Eleven

Attach Seat Panel (I) to Connecting Bar for Seat Panel (ML3).

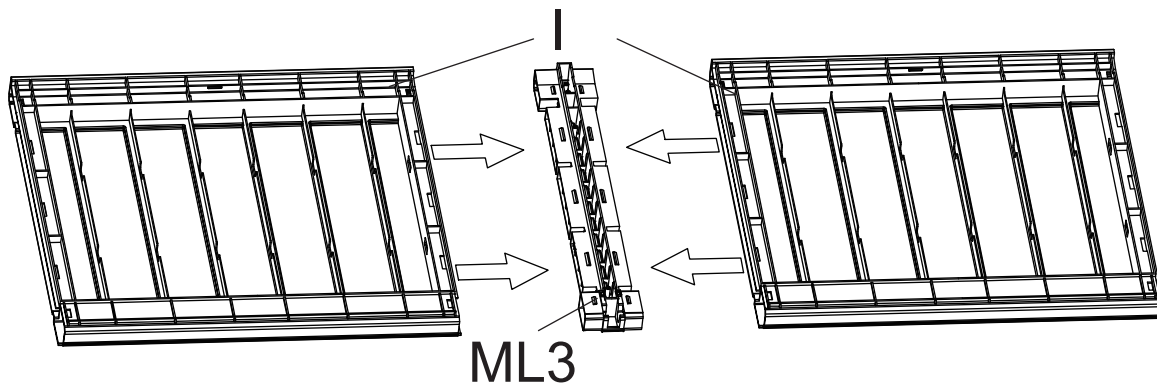

### Step Twelve

Place the Seat Panels (I) onto the assembled parts.  
Plug in the Caps (O).  
Your Storage Bench is ready for use.

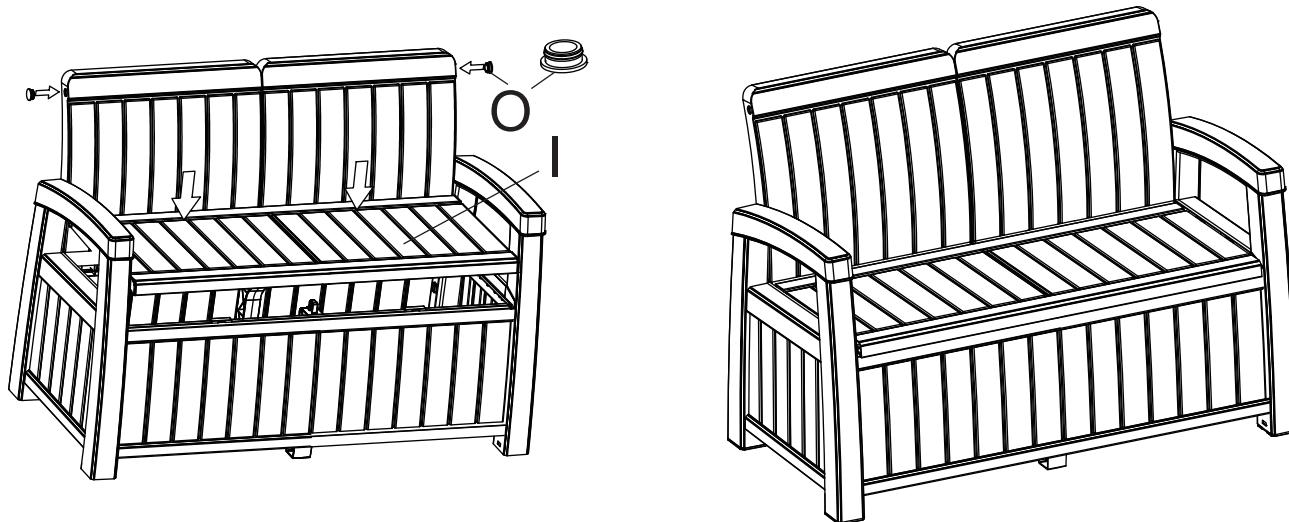

Never tilt the products during use.  
Ensure the product is always placed firmly on the ground.

**PLEASE KEEP THESE INSTRUCTIONS FOR FUTURE REFERENCE**