

Product size:

Arm Chair: W66*D71.6*H78.6 cm

Coffee Table: L38.9*W38.9*H42 cm

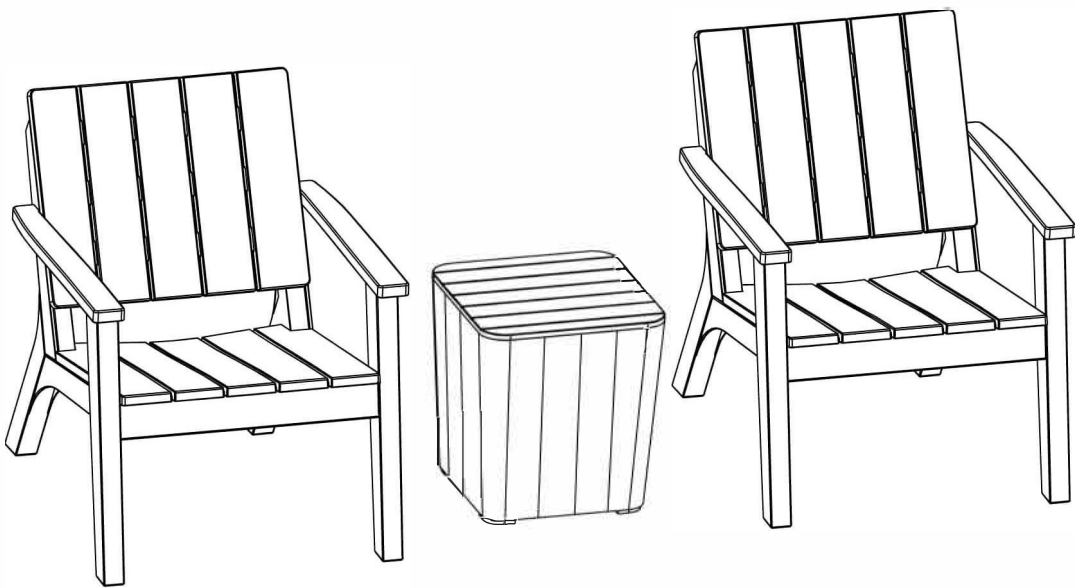

An environment-friendly product made of polypropylene
which can be recyclable after end of use.

The intended use of this product is for domestic use only.

Important, please retain for future reference.

Read carefully.



Faro Relax 3pcs Bistro Set - Slatted Wood Grain Effect Assembly Instructions

Before you start



Warnings

IMPORTANT, RETAIN FOR FUTURE REFERENCE READ CAREFULLY

See enclosed instructions for assembly, safety and care information.

Failure to follow the warnings could result in serious injury.

Handle heavy parts with care.

Ensure that this product is fully assembled as illustrated before use.

This product should only be used on firm, level ground.

Keep small parts out of reach of children.

This product is intended for **domestic use** only.

Ensure the product is always placed on level ground.

Furniture can be dangerous if incorrectly used. No liability will be accepted for damage or injury caused by incorrect use of this product.



Dos

When you are ready to start, make sure that you have the right tools, plenty of space and a clean, dry area for assembly.

Unwrap all packaging materials and place the components on a suitable surface to prevent scratching your product.

Check all contents are present prior to assembly as per the parts list provided. In the event of problems or missing parts, please contact the seller.

Check all screws and bolts are tightened and inspect regularly.

Cover furniture when not in use to add additional protection to your product.

During severe weather conditions, including high winds, rain, hail, thunderstorms, extreme heat and cold temperatures, the product should be stored inside in a cool, dry place.

To best preserve this product, please use a protective cover when your furniture is not in use. This will help prevent harmful UV rays from damaging and discolouring the material.

Ensure that the product is clean and dry before storage.

Clean your product with a sponge and warm soapy water then wipe with a clean, dry cloth.

Cushions should be cleaned following the care instruction on the label.

Where instructions as to the; storage, commissioning, installation, use and maintenance of the goods or (if there is none) good trade practice are not followed and a defect arises this will void the 12 month manufacturer's guarantee on the product.

X Don'ts

Do not use scourers, abrasives, washing powders, chemical cleaners or any other substances containing abrasives since these substances can damage the product.

To preserve the table top design do not place greasy / oily items directly onto the surface. Use place-mats to prevent spillages of food or drink.

Do not place very hot or very cold items on the surface unless adequately thick table-mats are used to prevent such items from coming into contact with the product.

Do not use the table as a chopping surface.

Do not strike the table with hard or pointed items.

Do not sit or lean on the table.

Do not use power tools to construct this product.

Do not use this product if parts are missing, damaged or worn.

Do not stand or climb onto the product and do not use it as a ladder, as this could lead to it unbalancing and overturning.

Never drag furniture when moving it, always lift it.

Number of people required for assembly

Two people



Time to assemble

40 minutes

Tools required

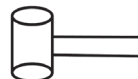
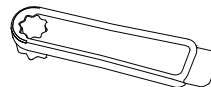

(Rubber Hammer may be required, not provided)

Tips:

Do NOT fully tighten bolts before all components are connected. Only fully tighten once you are satisfied with the alignment of all components.

Do not overtighten bolts.

www.a-mir.co.uk

Faro Relax 3pcs Bistro Set - Slatted Wood Grain Effect

Assembly Instructions

This Set is composed of 3 pieces.

Please find the member parts.

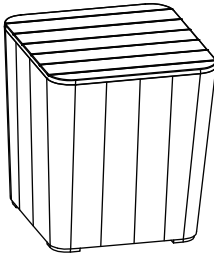
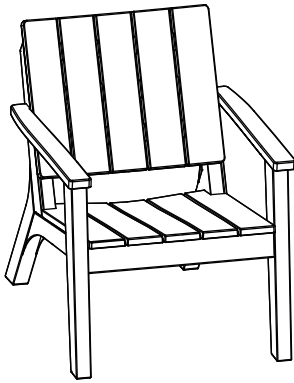
Member Part			
Part No.	Diagram	Name	Qty.
MP1		Coffee Table	1 PC
MP2		Arm Chair	2 PCS



Faro Relax 3pcs Bistro Set - Slatted Wood Grain Effect

Assembly Instructions

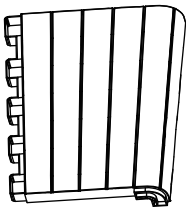
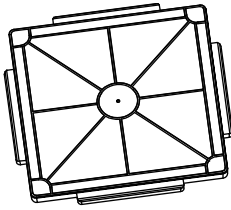
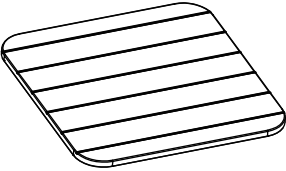
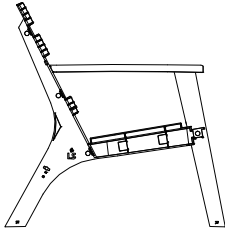
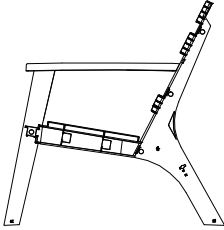
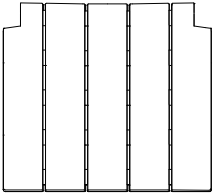
Components, fixtures & fittings (not actual size)

Parts List					
Part No.	Diagram	Qty.	Part No.	Diagram	Qty.
ST	 Coffee Table Side Panel	4 PCS	FT	 Coffee Table Bottom Panel	1 PC
F	 Coffee Table Lid	1 PC	LS	 Left Leg/Armrest	2 PCS
RS	 Right Leg/Armrest	2 PCS	S	 Seat Panel	2 PCS

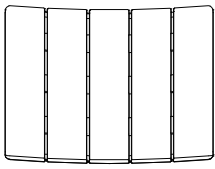
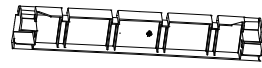
Faro Relax 3pcs Bistro Set - Slatted Wood Grain Effect Assembly Instructions

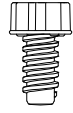
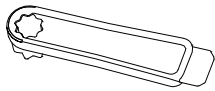
B	 Backrest	2 PCS	CF	 Front Bar	2 PCS
CR	 Rear Bar	2 PCS	J	 Bolt	16 PCS
K	 Spanner	1 PC			

Step by step assembly instructions

Faro Relax 3pcs Bistro Set - Slatted Wood Grain Effect Assembly Instructions

MP1 – Coffee Table

Step One

Combine the Coffee Table Side Panels (ST).

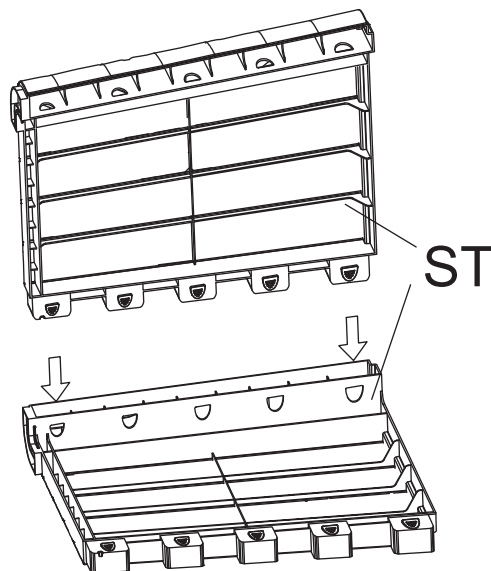

Step Two

Attach the Bottom Panel (FT) to the Side Panels (ST).

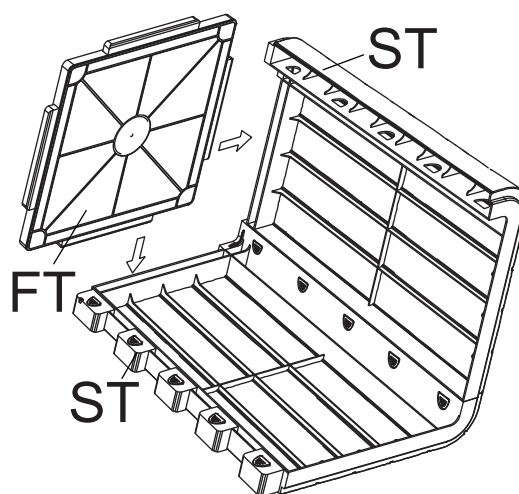

Faro Relax 3pcs Bistro Set - Slatted Wood Grain Effect Assembly Instructions

Step Three

Attach other two pieces of Side Panels (ST) to the above partly-assembled Parts (ST) and (FT).

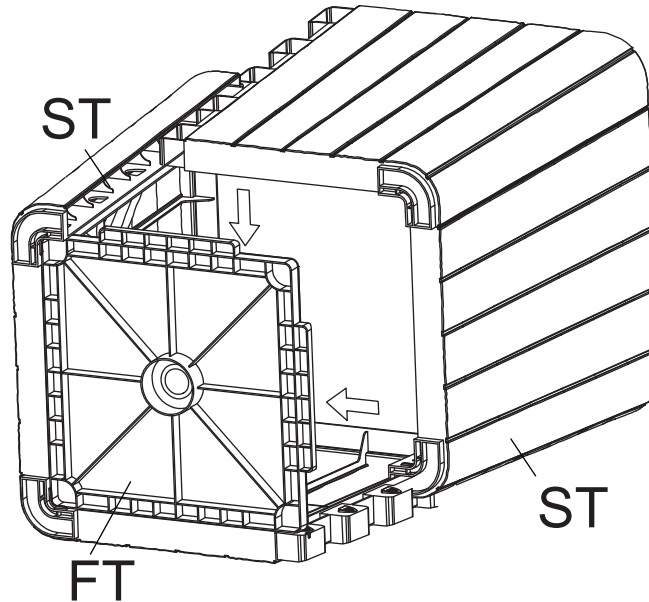

Step Four

Place the Coffee Table Lid (T) onto the assembled parts.

Your Coffee Table is now ready for use.

Note: This Coffee Table is with storage facility.

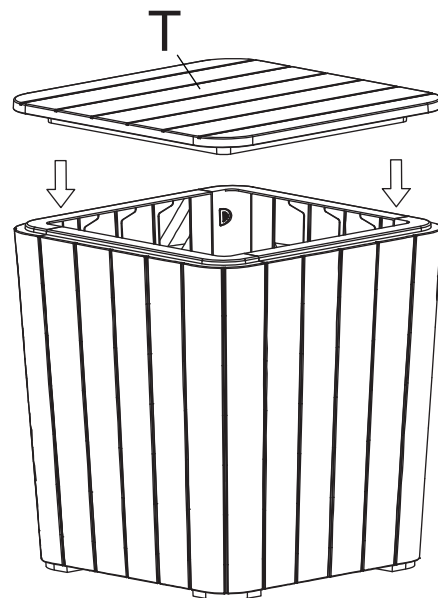

Faro Relax 3pcs Bistro Set - Slatted Wood Grain Effect Assembly Instructions

MP2 – Arm Chair

Step One

Attach Front Bar (CF) to the Left Leg/Armrest (LS) and Right Leg/Armrest (RS).

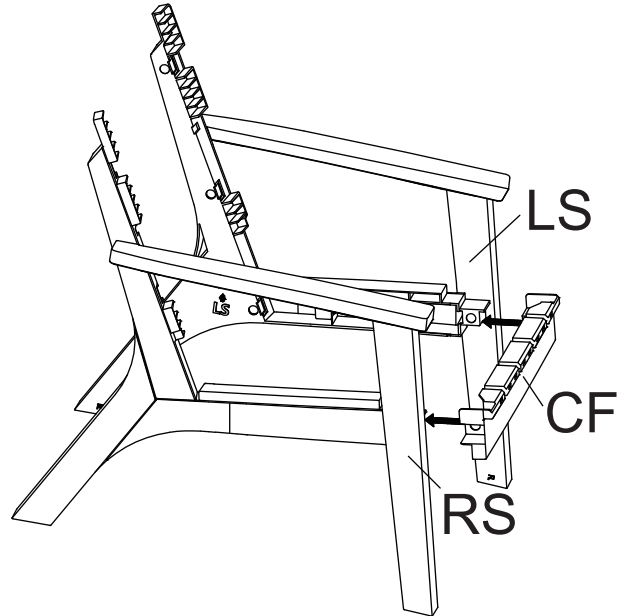

Step Two

Attach Rear Bar (CR) to the Left Leg/Armrest (LS) and Right Leg/Armrest (RS).

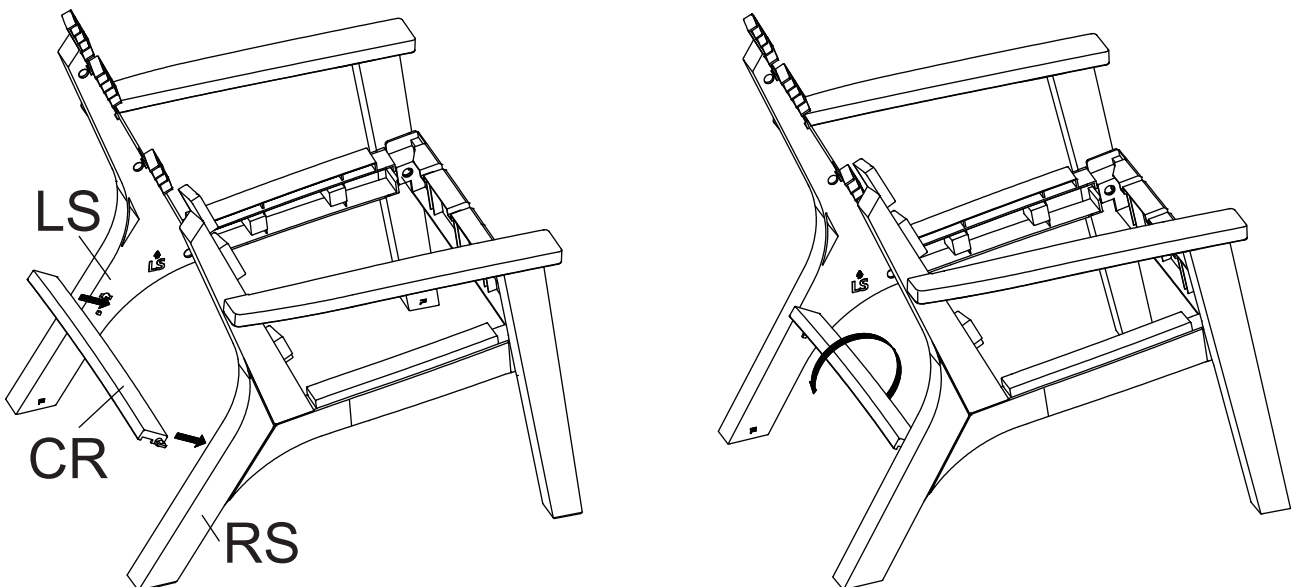

Faro Relax 3pcs Bistro Set - Slatted Wood Grain Effect Assembly Instructions

Step Three

Attach the Seat Panel (S) to the above partly-assembled components.

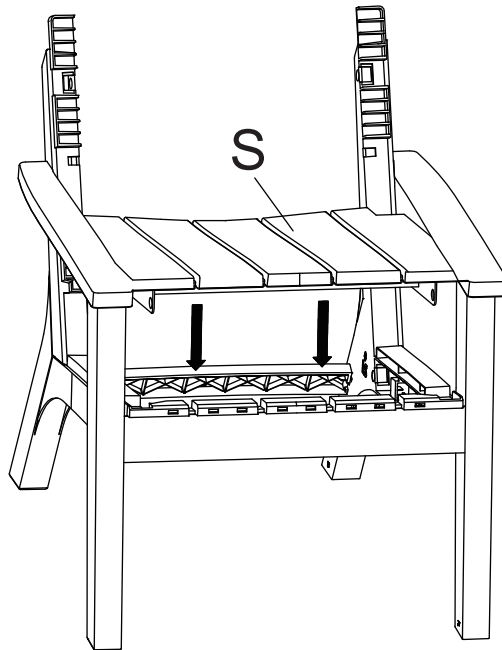

Step Four

Attach the Backrest (B) to the Left Leg/Armrest (LS) and Right Leg/Armrest (RS).

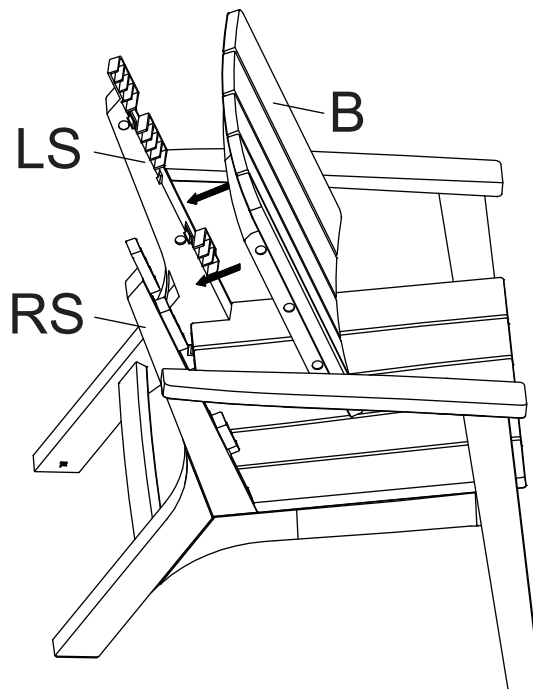

Faro Relax 3pcs Bistro Set - Slatted Wood Grain Effect Assembly Instructions

Step Five

Make all components are aligned properly, loosely attach Bolts (J) to the joints, tighten the Bolts (J) by Spanner (K). Do not over-tighten. There are 8 Bolts for each Chair.

Place the Arm Chair in upright position.

Your Arm Chair is now ready for use.

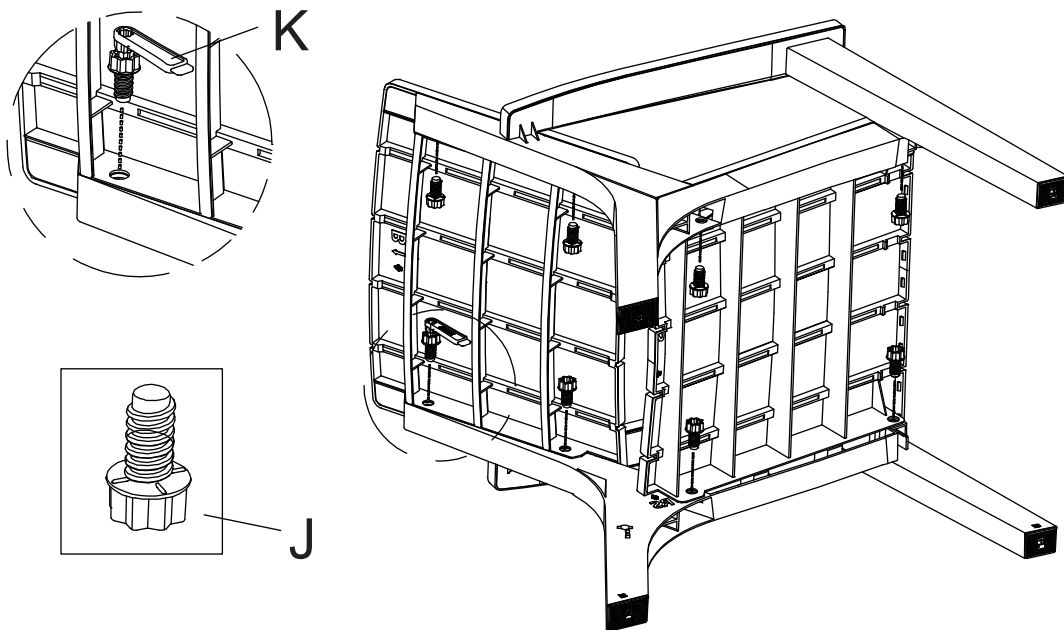

Never tilt the product during use.
Ensure the product is always placed firmly
on the ground.

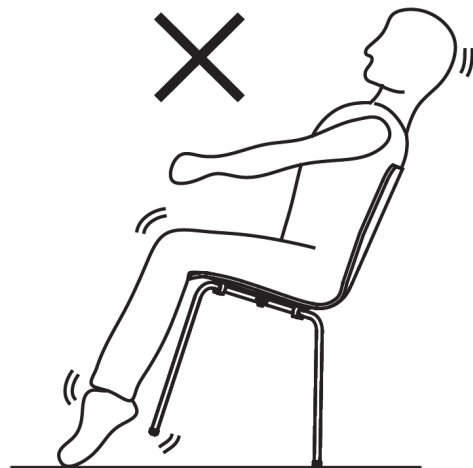

PLEASE KEEP THESE INSTRUCTIONS FOR FUTURE REFERENCE