

Product size:

Coffee Table: 76.1*50.1*H41.5 cm

Arm Chair: W66*D71.6*H78.6 cm

Bench: W120.5*D71.6*H78.6 cm

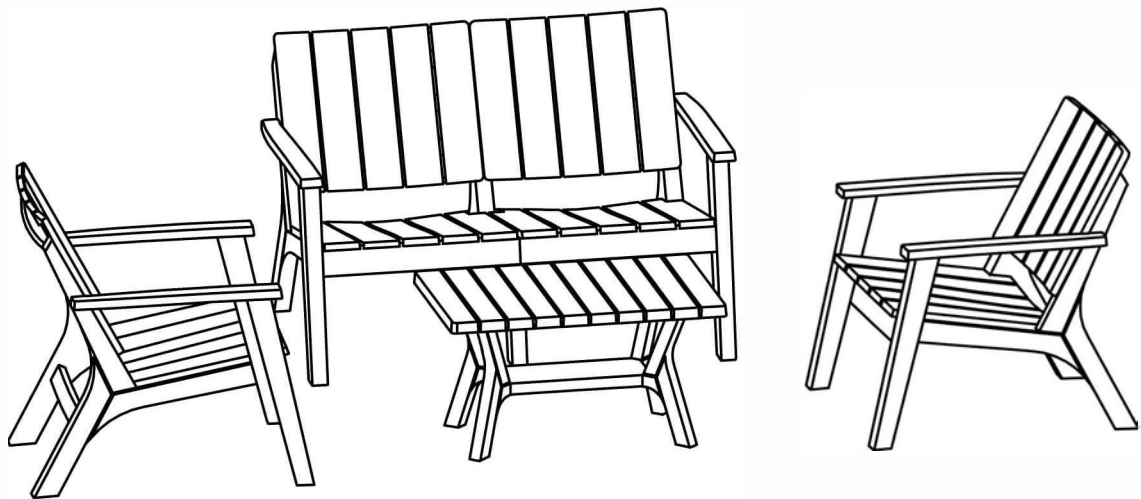

An environment-friendly product made of polypropylene
which can be recyclable after end of use.

The intended use of this product is for domestic use only.

Important, please retain for future reference.

Read carefully.



Faro 4pcs Conversation Set - Slatted Wood Grain Effect

Assembly Instructions

Before you start



Warnings

IMPORTANT, RETAIN FOR FUTURE REFERENCE READ CAREFULLY

See enclosed instructions for assembly, safety and care information.

Failure to follow the warnings could result in serious injury.

Handle heavy parts with care.

Ensure that this product is fully assembled as illustrated before use.

This product should only be used on firm, level ground.

Keep small parts out of reach of children.

This product is intended for **domestic use** only.

Ensure the product is always placed on level ground.

Furniture can be dangerous if incorrectly used. No liability will be accepted for damage or injury caused by incorrect use of this product.



Dos

When you are ready to start, make sure that you have the right tools, plenty of space and a clean, dry area for assembly.

Unwrap all packaging materials and place the components on a suitable surface to prevent scratching your product.

Check all contents are present prior to assembly as per the parts list provided. In the event of problems or missing parts, please contact the seller.

Check all screws and bolts are tightened and inspect regularly.

Cover furniture when not in use to add additional protection to your product.

Store all cushions indoors after use as they are not waterproof.

During severe weather conditions, including high winds, rain, hail, thunderstorms, extreme heat and cold temperatures, the product should be stored inside in a cool, dry place.

To best preserve this product, please use a protective cover when your furniture is not in use. This will help prevent harmful UV rays from damaging and discolouring the material.

Ensure that the product is clean and dry before storage.

Clean your product with a sponge and warm soapy water then wipe with a clean, dry cloth.

Cushions should be cleaned following the care instruction on the label.

Where instructions as to the; storage, commissioning, installation, use and maintenance of the goods or (if there is none) good trade practice are not followed and a defect arises this will void the 12 month manufacturer's guarantee on the product.

X Don'ts

Do not use scourers, abrasives, washing powders, chemical cleaners or any other substances containing abrasives since these substances can damage the product.

To preserve the table top design do not place greasy / oily items directly onto the surface. Use place-mats to prevent spillages of food or drink.

Do not place very hot or very cold items on the surface unless adequately thick table-mats are used to prevent such items from coming into contact with the product.

Do not use the table as a chopping surface.

Do not strike the table with hard or pointed items.

Do not sit or lean on the table.

Do not use power tools to construct this product.

Do not use this product if parts are missing, damaged or worn.

Do not stand or climb onto the product and do not use it as a ladder, as this could lead to it unbalancing and overturning.

Never drag furniture when moving it, always lift it.

Number of people required for assembly

Two people



Time to assemble

45 minutes

Tools required

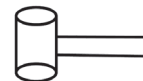

(Rubber Hammer may be required, not provided)

Tips:

Do NOT fully tighten bolts before all components are connected. Only fully tighten once you are satisfied with the alignment of all components.

Do not overtighten bolts.

www.a-mir.co.uk



Faro 4pcs Conversation Set - Slatted Wood Grain Effect

Assembly Instructions

This Set is composed of 4 pieces.

Please find the member parts.

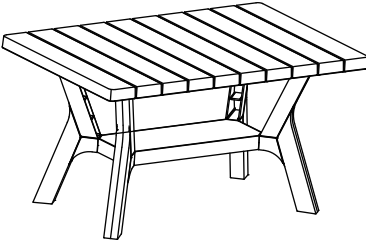
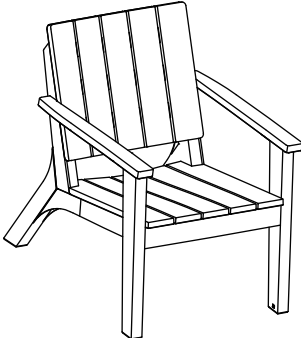
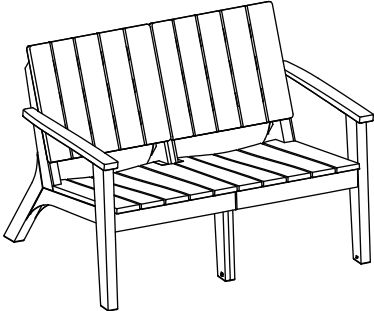
Member Part			
Part No.	Diagram	Name	Qty.
MP1		Coffee Table	1 PC
MP2		Arm Chair	2 PCS
MP3		Bench	1 PC

Faro 4pcs Conversation Set - Slatted Wood Grain Effect

Assembly Instructions

Components, fixtures & fittings (not actual size)

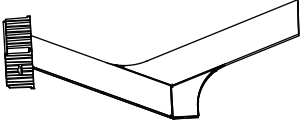
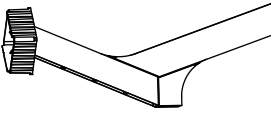
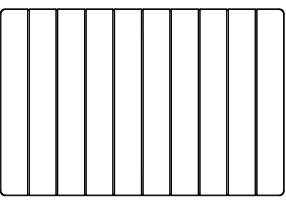
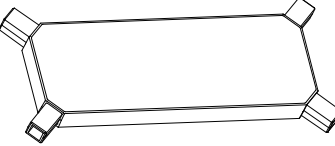
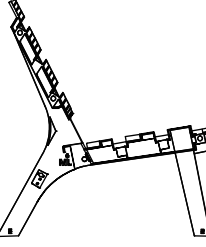
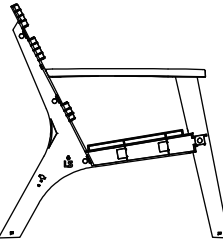
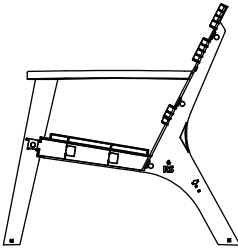
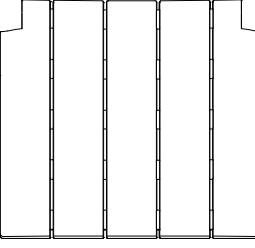

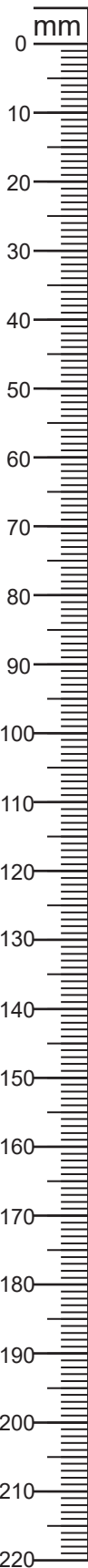
Parts List					
Part No.	Diagram	Qty.	Part No.	Diagram	Qty.
A	 Coffee Table Leg	2 PCS	A1	 Coffee Table Leg	2 PCS
C	 Coffee Table Top	1 PC	D	 Coffee Table Connecting Ring	1 PC
ML	 Middle Leg	1 PC	LS	 Left Leg/Armrest	3 PCS
RS	 Right Leg/Armrest	3 PCS	S	 Seat Panel	4 PCS



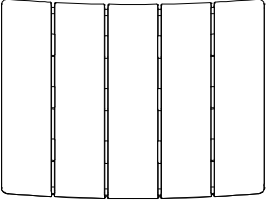
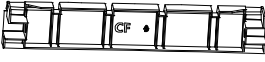

Faro 4pcs Conversation Set - Slatted Wood Grain Effect

Assembly Instructions

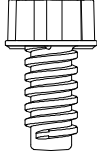
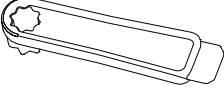
B	 Backrest	4 PCS	CF	 Front Bar	4 PCS
CR	 Rear Bar	4 PCS	L	 Bolt	32 PCS
M	 Spanner	1 PC			

Step by step assembly instructions

MP1 – Coffee Table

Step One

Attach Coffee Table Legs (A) and (A1) to the Connecting Ring (D).

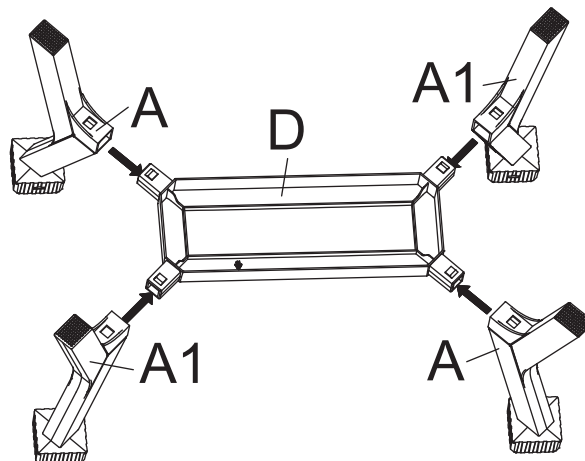

www.a-mir.co.uk

Step Two

Attach the above partly-assembled parts to the Coffee Table Top (C).
Place the Coffee Table in the upright position.

Your Coffee Table is now ready for use.

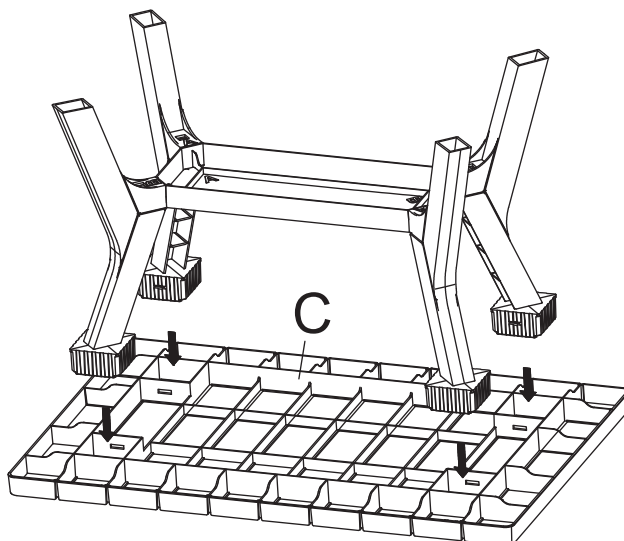

MP2 – Arm Chair

Step One

Attach Front Bar (CF) to the Left Leg/Armrest (LS)
and Right Leg/Armrest (RS).

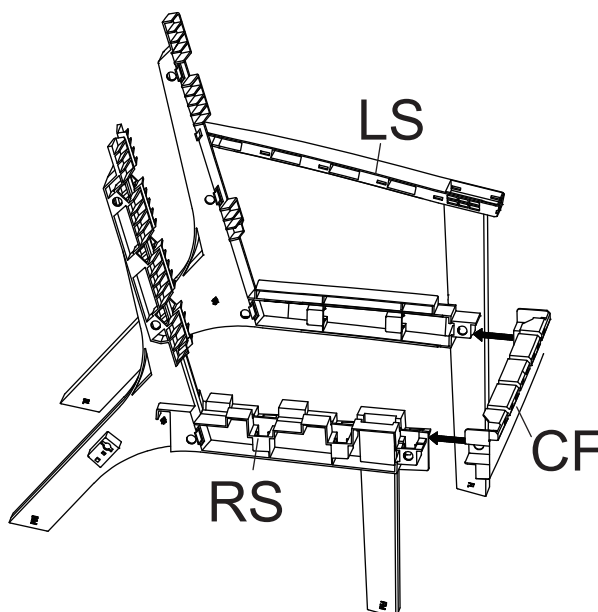

Step Two

Attach Rear Bar (CR) to the Left Leg/Armrest (LS) and Right Leg/Armrest (RS).

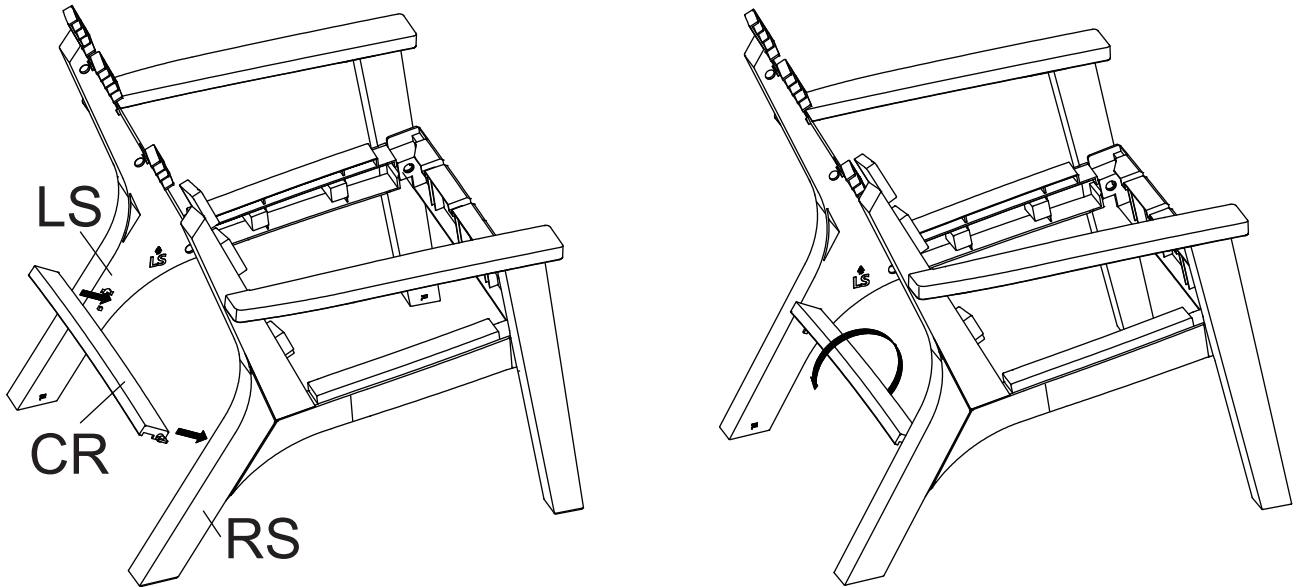

Step Three

Attach the Seat Panel (S) to the above partly-assembled components.

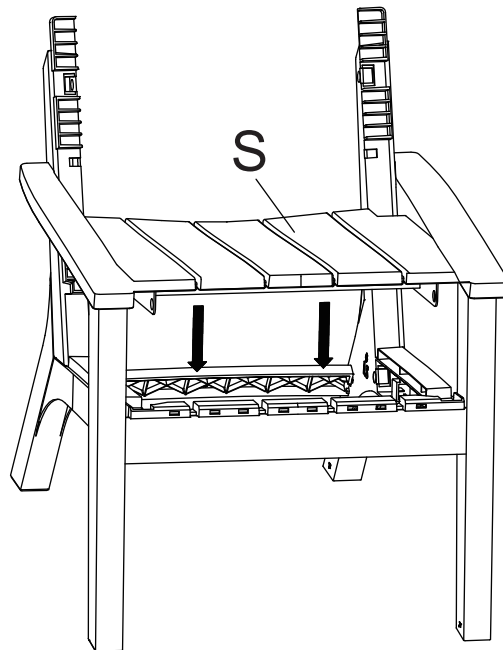

Step Four

Attach the Backrest (B) to the Left Leg/Armrest (LS) and Right Leg/Armrest (RS).

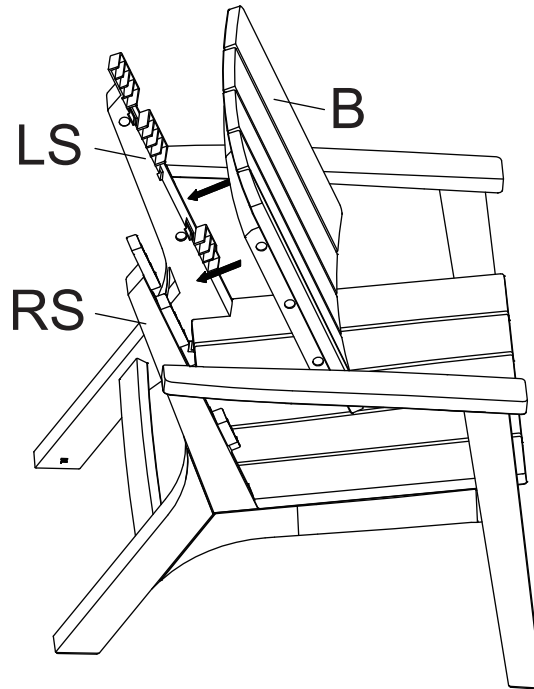

Step Five

Make all components are aligned properly, loosely attach Bolts (L) to the joints, tighten the Bolts (L) by Spanner (M). Do not over-tighten. There are 8 Bolts for each Chair.

Place the Arm Chair in upright position.

Your Arm Chair is now ready for use.

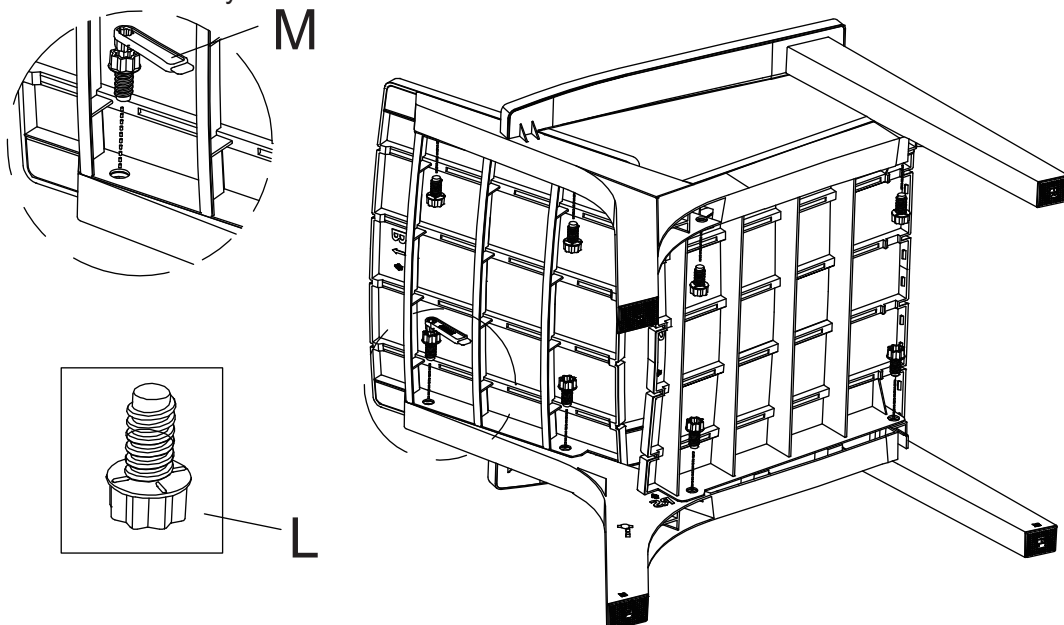

MP3 – Bench

Step One

Attach Front Bar (CF) to the Left Leg/Armrest (LS) and Middle Leg (ML).

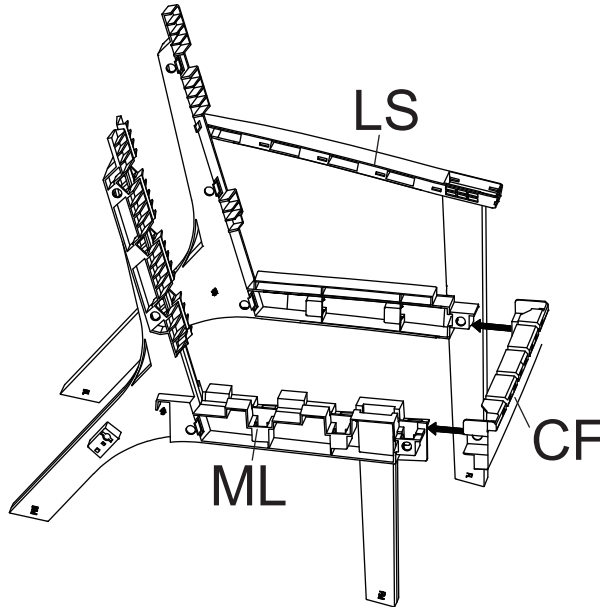

Step Two

Attach Rear Bar (CR) to the Left Leg/Armrest (LS) and Middle Leg (ML).

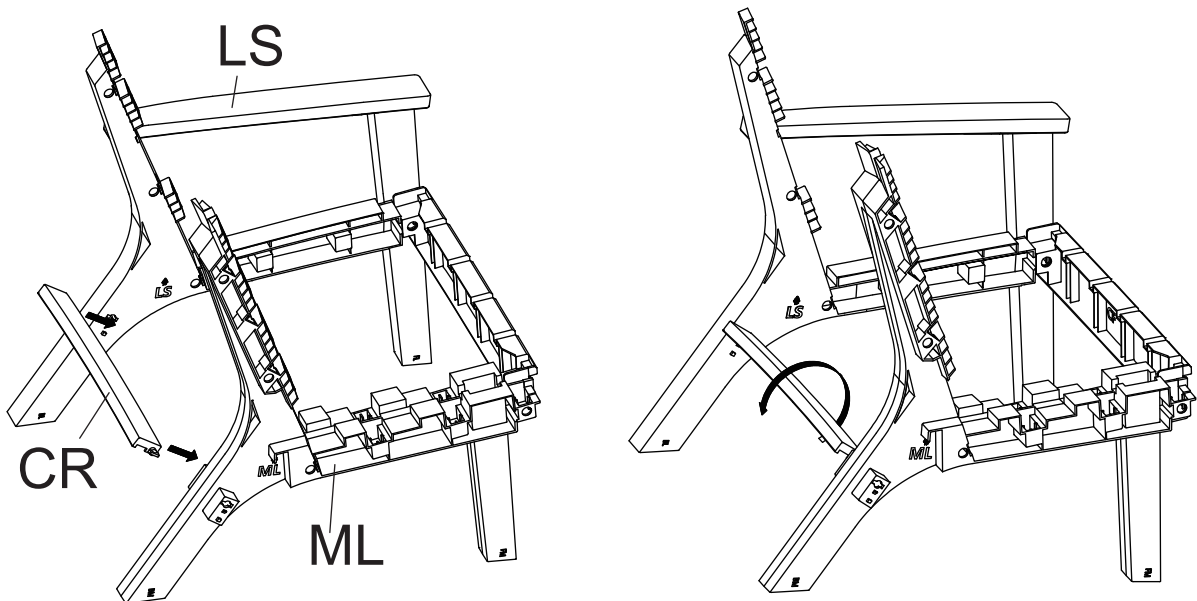

Step Three

Attach Front Bar (CF) to the Right Leg/Armrest (RS) and Middle Leg (ML).

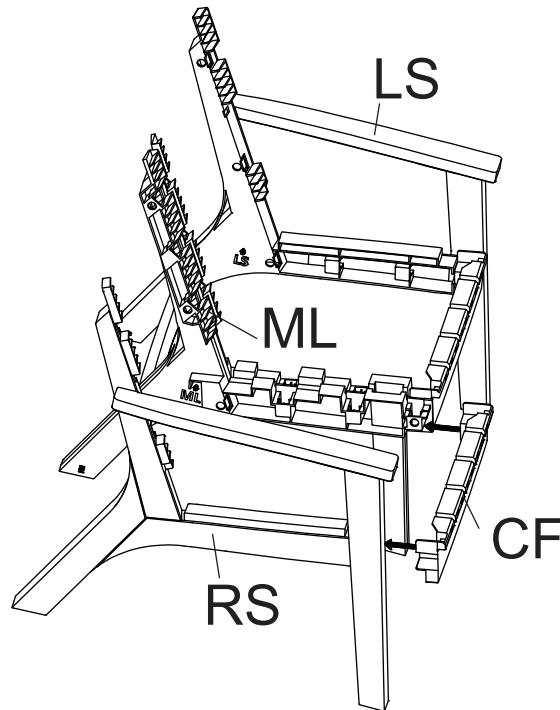

Step Four

Attach Rear Bar (CR) to the Right Leg/Armrest (RS) and Middle Leg (ML).

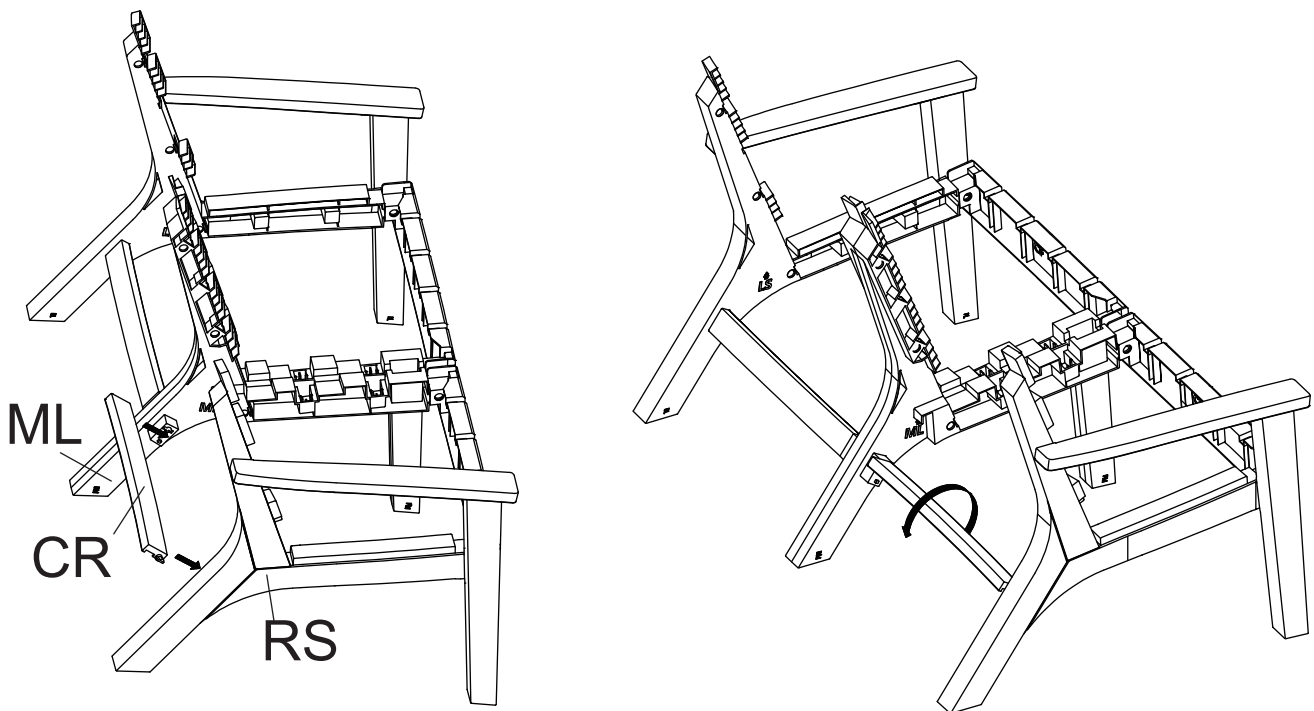

Step Five

Attach the Seat Panel (S) to the above partly-assembled components.

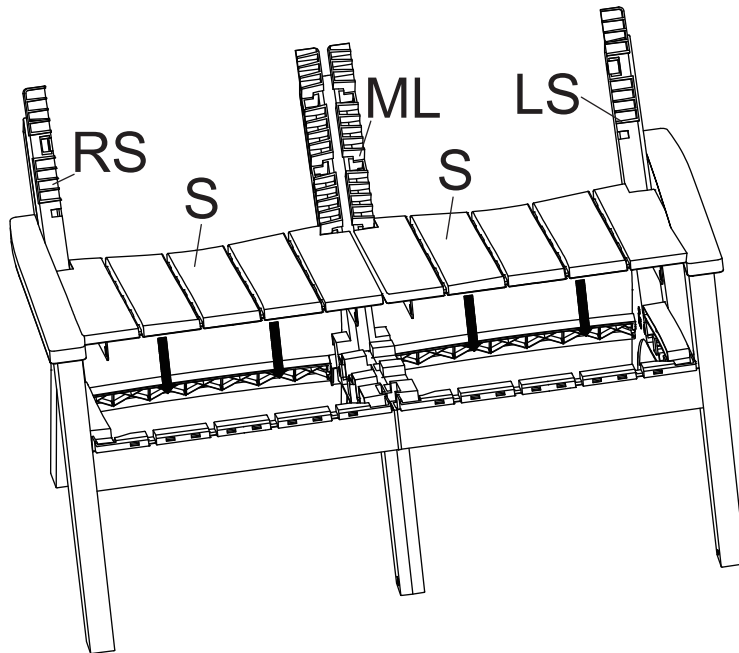

Step Six

Attach the Backrests (B) to the Left Leg/Armrest (LS), Middle Leg (ML) and Right Leg/Armrest (RS).

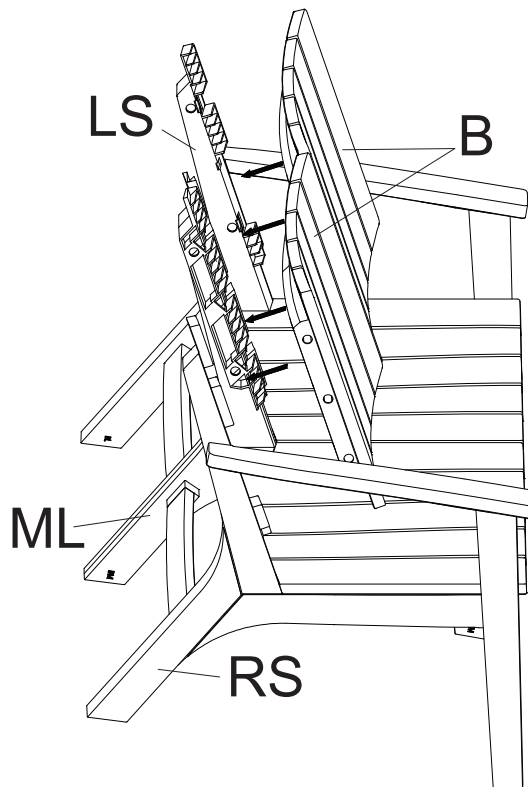

Step Seven

Make all components are aligned properly, loosely attach Bolts (L) to the joints, tighten the Bolts (L) by Spanner (M). Do not over-tighten. There are 8 Bolts for each Chair.

Place the Bench in upright position.

Your Bench is now ready for use.

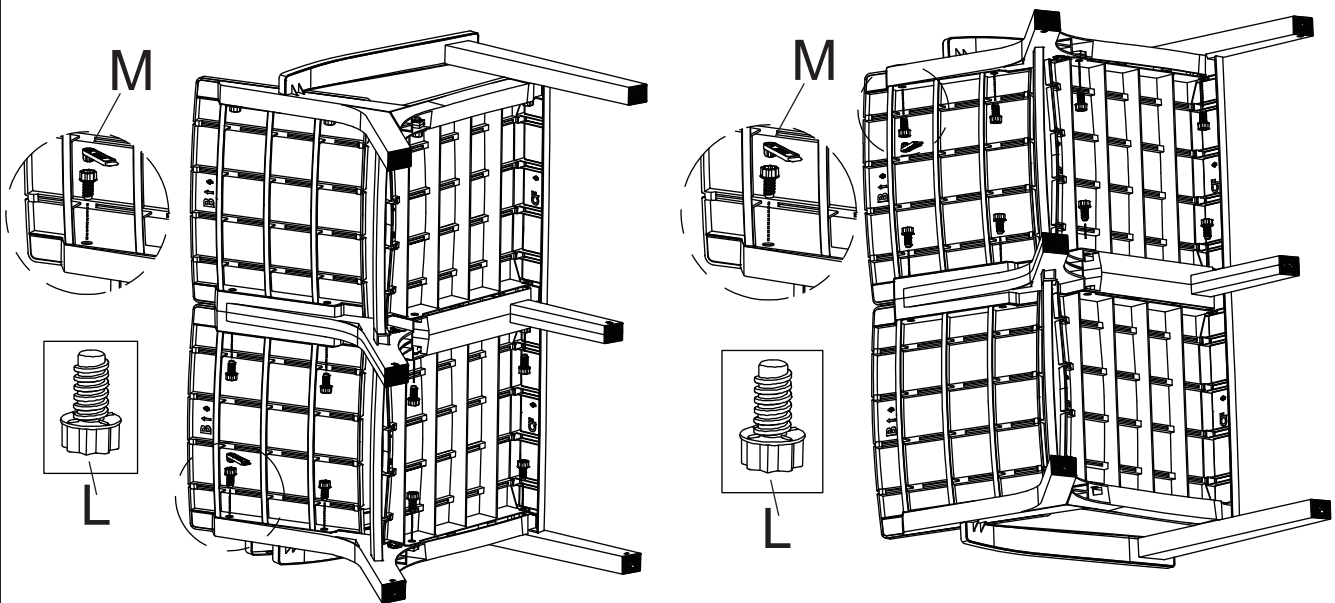

Never tilt the product during use.
Ensure the product is always placed firmly
on the ground.

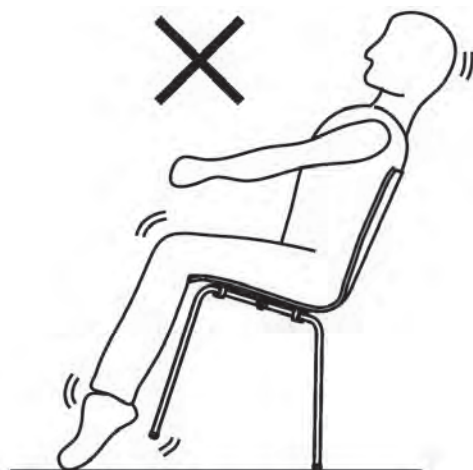

PLEASE KEEP THESE INSTRUCTIONS FOR FUTURE REFERENCE