

Product size:

3-Seater Sofa: W179*D70*H75/81 cm

Armchair: W69*D70*H75/81 cm

Coffee Table: L110*W55*H43 cm

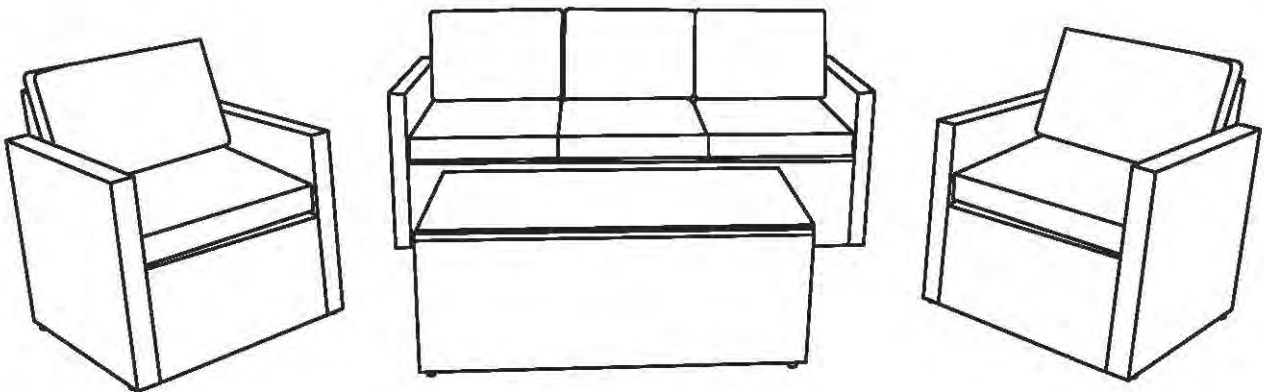

Furniture should be covered/stored whilst not in use to prolong its longevity.

(It should also be covered in adverse weather.)

The intended use of this product is for domestic use only.

Important, please retain for future reference.

Read carefully.

Before you start



Warnings

IMPORTANT, RETAIN FOR FUTURE REFERENCE READ CAREFULLY

See enclosed instructions for assembly, safety and care information.

Failure to follow the warnings could result in serious injury.

Handle heavy parts with care.

Ensure that this product is fully assembled as illustrated before use.

This product should only be used on firm, level ground.

Keep small parts out of reach of children.

Do not stand or climb onto this product.

This product is intended for **domestic use** only.

Furniture can be dangerous if incorrectly used. No liability will be accepted for damage or injury caused by incorrect use of this product.

✓ Dos

When you are ready to start, make sure that you have the right tools, plenty of space and a clean, dry area for assembly.

Unwrap all packaging materials and place the components on a suitable surface to prevent scratching your product.

Check all contents are present prior to assembly as per the parts list provided. In the event of problems or missing parts, please contact the seller.

Check all screws and bolts are tightened and inspect regularly.

Cover furniture when not in use to add additional protection to your product.

Store all cushions indoors after use as they are not waterproof.

During severe weather conditions, including high winds, rain, hail, thunderstorms, extreme heat and cold temperatures, the product should be stored inside in a cool, dry place.

To best preserve the synthetic rattan, please use a protective cover when your furniture is not in use. We would also recommend using a gazebo or parasol over your furniture during the summer period and prolonged sunny spells. This will help prevent harmful UV rays from damaging and discolouring the material.

Ensure that the product is clean and dry before storage.

Clean your product with a sponge and warm soapy water then wipe with a clean, dry cloth.

Cushions should be cleaned following the care instruction on the label.

Where instructions as to the; storage, commissioning, installation, use and maintenance of the goods or (if there is none) good trade practice are not followed and a defect arises this will void the 12 month manufacturer's guarantee on the product.

✗ Don'ts

Never tilt the chair during use.

Do not stand or climb onto the product.

Do not use power tools to construct this product.

Do not sit or lean onto the arms of this product.

Do not use this product if parts are missing, damaged or worn.

Do not use scourers, abrasives, washing powders, chemical cleaners or any other substances containing abrasives since these substances can damage the product.

To preserve the table top design do not place greasy / oily items directly onto the surface. Use place-mats to prevent spillages of food or drink.

Do not place very hot or very cold items on the glass surface unless adequately thick table-mats are used to prevent such items from coming into contact with the glass.

Do not use the table as a chopping surface.

Do not strike the table with hard or pointed items.

Do not sit or lean on the table.

Do not use this product as a ladder as this could lead to the product becoming unbalanced and overturning.

Do not place very hot or very cold items on this product surface.

Never drag furniture when moving it, always lift it.

Number of people required for assembly

Two people



Time to assemble

50 minutes

Tools required



Tips:

Do NOT fully tighten bolts before all components are connected. Only fully tighten once you are satisfied with the alignment of all components. Do not overtighten bolts.



Berlin 5 Seater Sofa Set

Assembly Instructions

This Sofa Set is a set of 4 pieces.

Please find the Components.

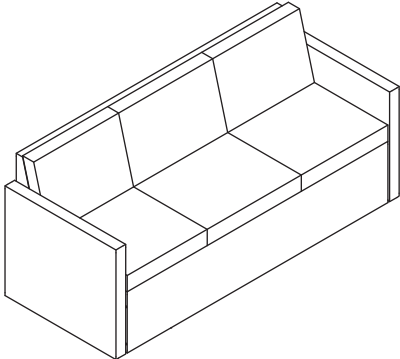
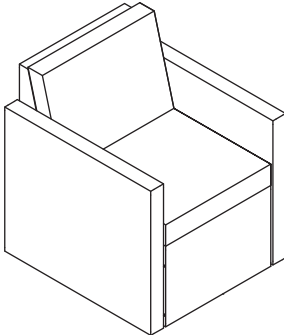
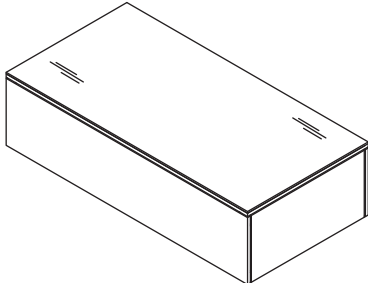
No.	Diagram	Name	Qty.
1		3-Seater Sofa	1 PC
2		Armchair	2 PCS
3		Coffee Table	1 PC

www.royalcraft.co.uk

Berlin 5 Seater Sofa Set

Assembly Instructions

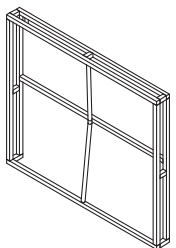
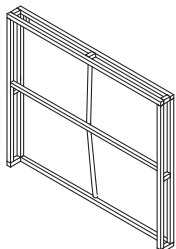
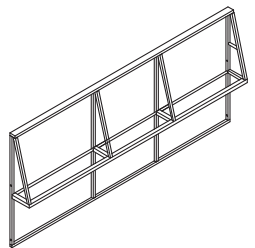
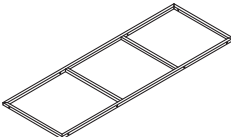
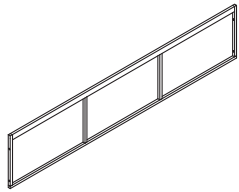
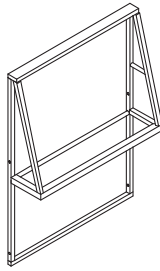
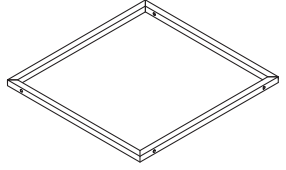
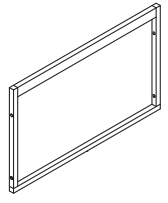

Parts, fixtures & fittings (not actual size)

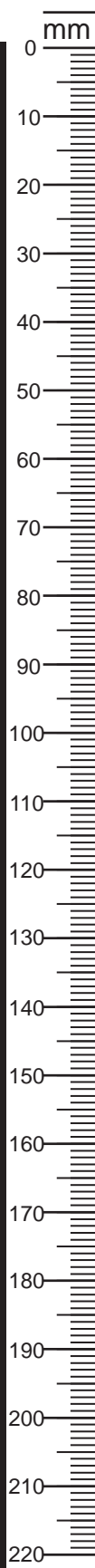
Parts List					
Part No.	Diagram	Qty.	Part No.	Diagram	Qty.
A	 Right Leg	3 PCS	B	 Left Leg	3 PCS
C	 3-Seater Sofa Backrest	1 PC	D	 3-Seater Sofa Seat	1 PC
E	 3-Seater Sofa Front Panel	1 PC	F	 Armchair Backrest	2 PCS
G	 Armchair Seat	2 PCS	H	 Armchair Front Panel	2 PCS

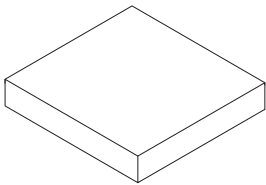
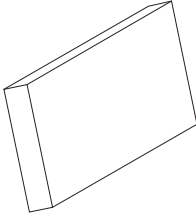
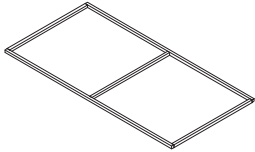
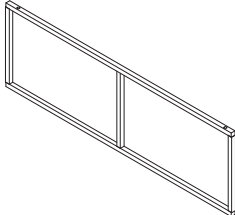
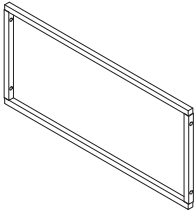
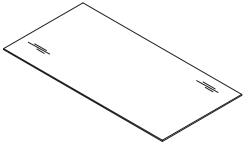
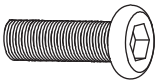
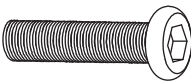

Berlin 5 Seater Sofa Set

Assembly Instructions

I	 Seat Cushion	5 PCS	J	 Backrest Cushion	5 PCS
K	 Coffee Table Top Frame	1 PC	L	 Long Panel	2 PCS
M	 Short Panel	2 PCS	N	 Glass Top	1 PC
N32	 M6*32mm Bolt	32 PCS	N37	 M6*37mm Bolt	16 PCS
F2	 Washer	48 PCS	AK	 Allen Key	2 PCS

Component 1 – 3-Seater Sofa: Assembly Steps

Step One

Loosely attach the Right Leg (A) and Left Leg (B) to the 3-Seater Sofa Backrest (C) using Washers (F2) and Bolts (N32).

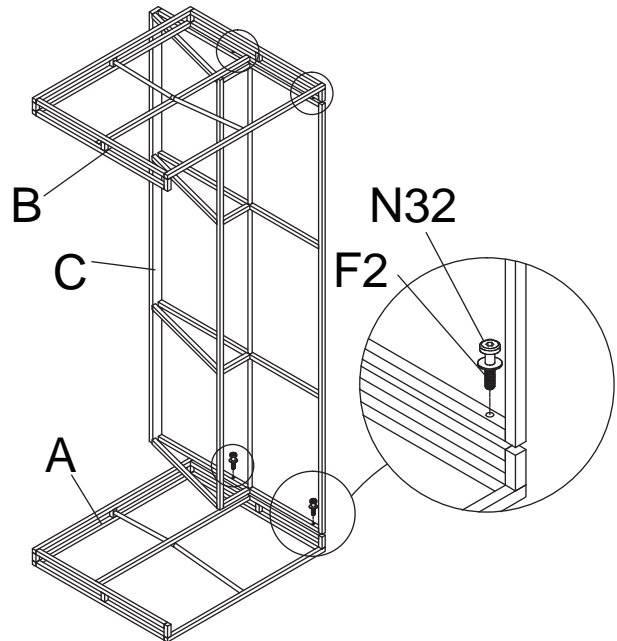

Step Two

Loosely attach the 3-Seater Sofa Front Panel (E) to the 3-Seater Sofa Seat (D) using Washers (F2) and Bolts (N37).

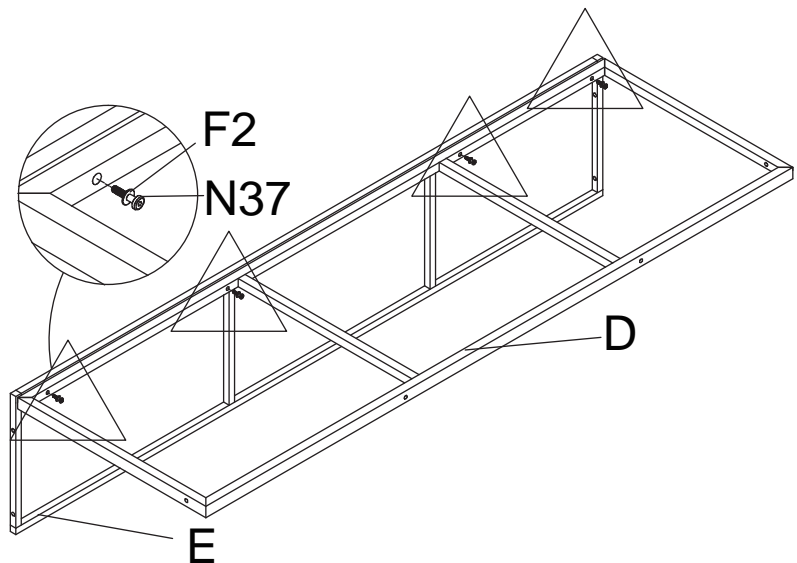

Berlin 5 Seater Sofa Set

Assembly Instructions

Step Three

Loosely attach above partly-assembled parts together using Washers (F2) and Bolts (N32 & N37).

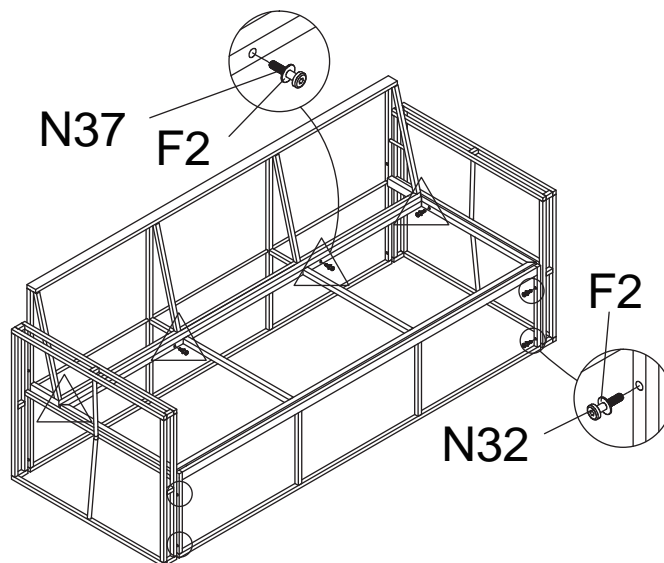

Step Four

With the help of another person, move the Sofa to the intended location, place the Seat Cushions (I) and Backrest Cushions (J) to the Sofa.

Your 3-Seater Sofa is now ready for use.

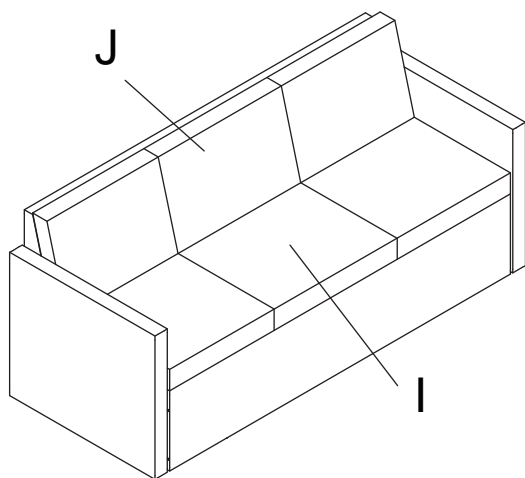
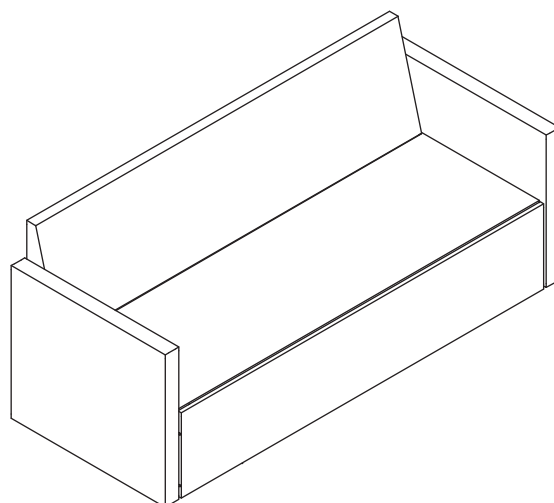

Component 2 – Armchair: Assembly Steps

Step One

Loosely attach the Right Leg (A) and Left Leg (B) to the Armchair Backrest (F) using Washers (F2) and Bolts (N32).

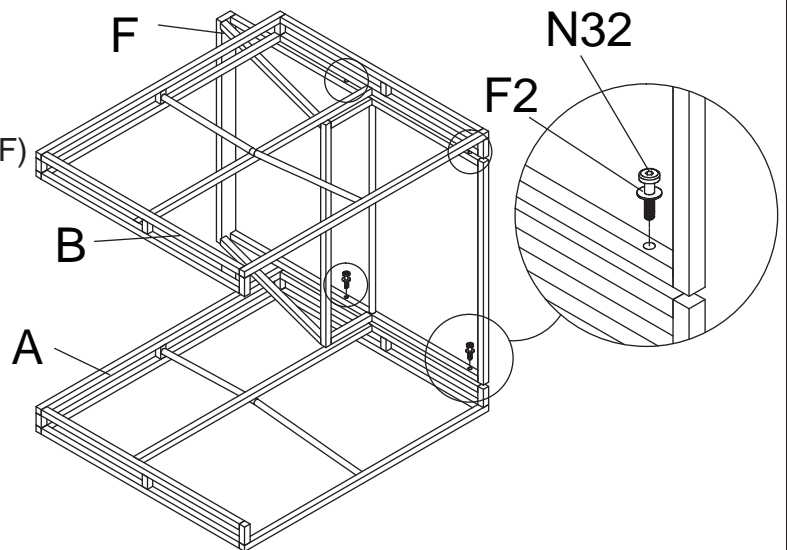

Step Two

Loosely attach the Armchair Front Panel (H) to the Armchair Seat (G) using Washers (F2) and Bolts (N37).

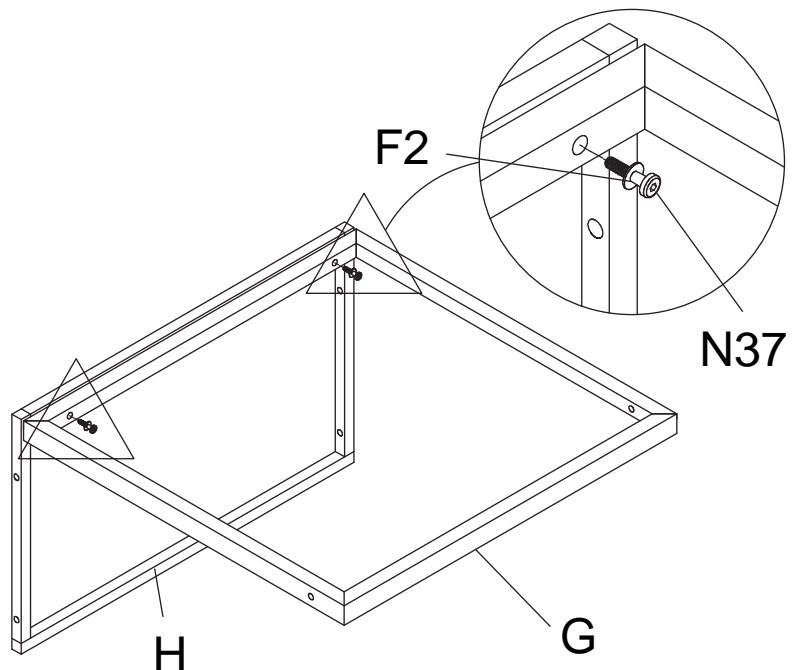

Berlin 5 Seater Sofa Set

Assembly Instructions

Step Three

Loosely attach above partly-assembled parts using Washers (F2) and Bolts (N32 & N37).

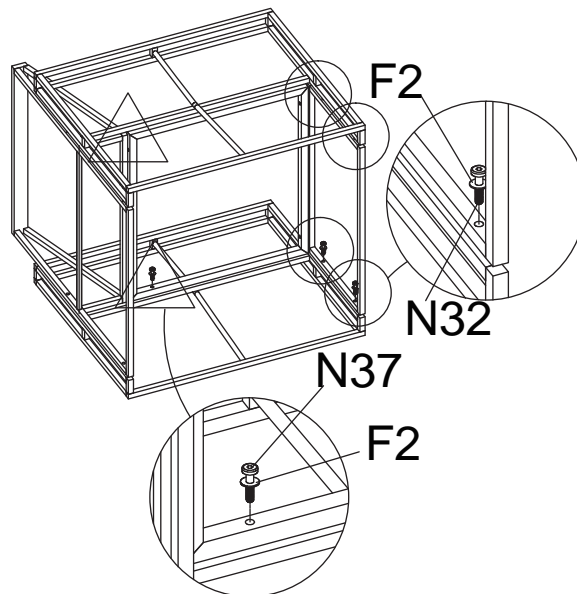

Step Four

With the help of another person, move the Sofa to the intended location, place the Seat Cushions (I) and Backrest Cushions (J) to the Armchair.

Your Armchair is now ready for use.

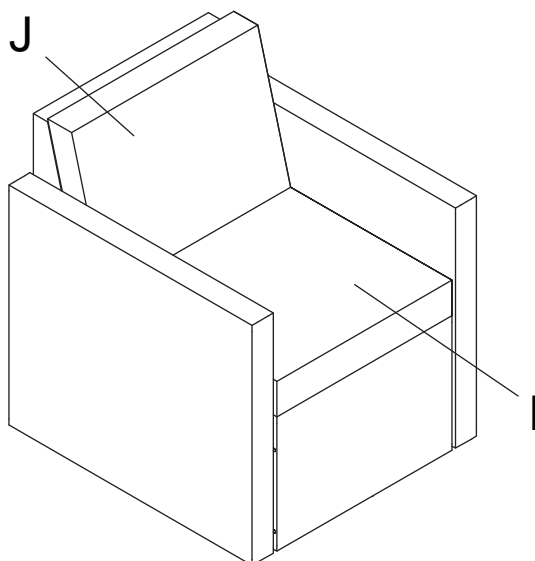
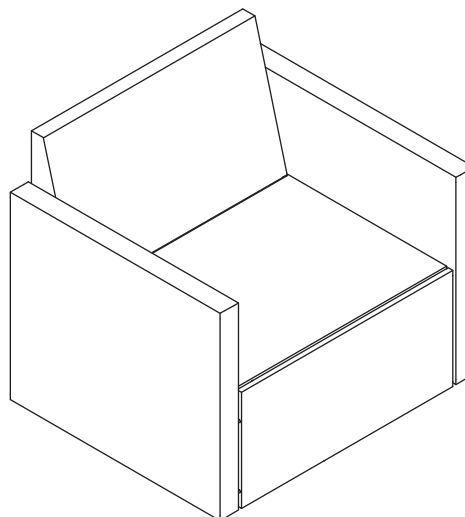

Component 3 – Coffee Table: Assembly Steps

Step One

With the help of another person, loosely attach the Short Panels (M) to the Long Panels (L) using Washers (F2) and Bolts (N32).

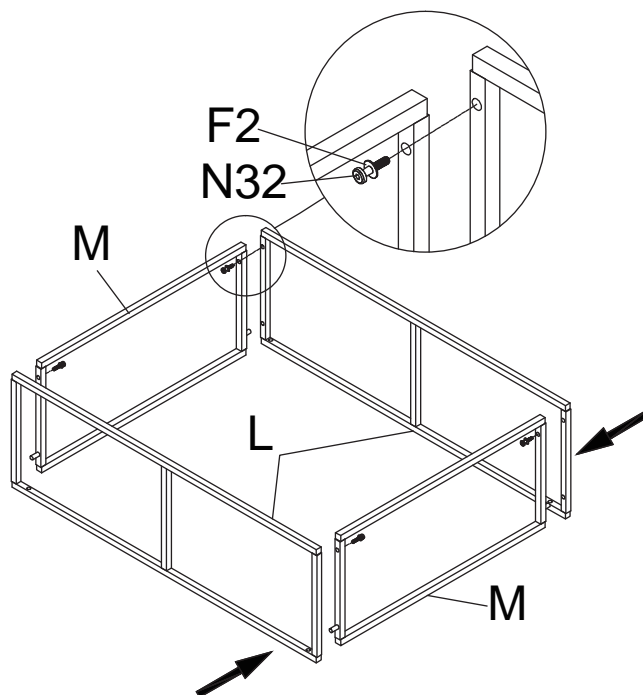

Step Two

Loosely attach the Coffee Table Top Frame (K) to the above parts using Washers (F2) and Bolts (N32).

Only tighten the bolts when all bolts and washers are in place and turn freely. Once you are satisfied with the alignment of the components carefully tighten all bolts using Allen Key (AK). Do not over-tighten.

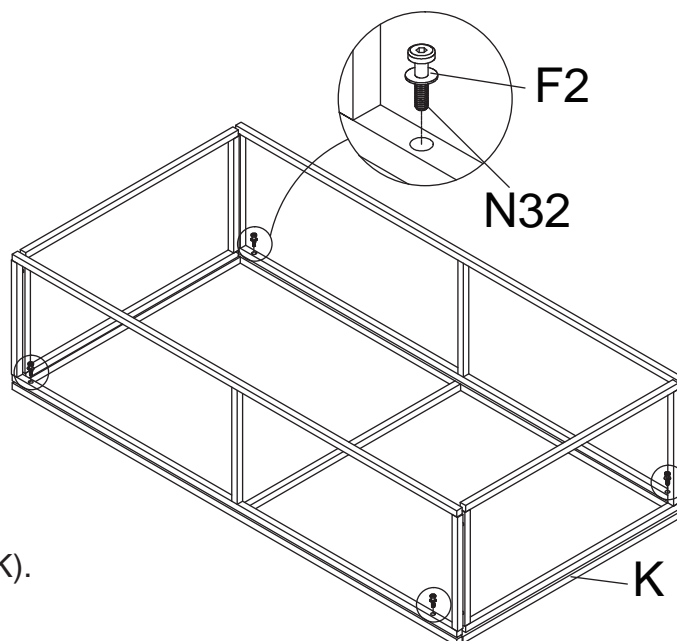

Step Three

With the help of another person, carefully turn the coffee table frame in the upright position.

Carefully place the Glass Top (N) on the Coffee Table Top Frame (K) and make sure they match each other.

Your Coffee Table is now ready for use

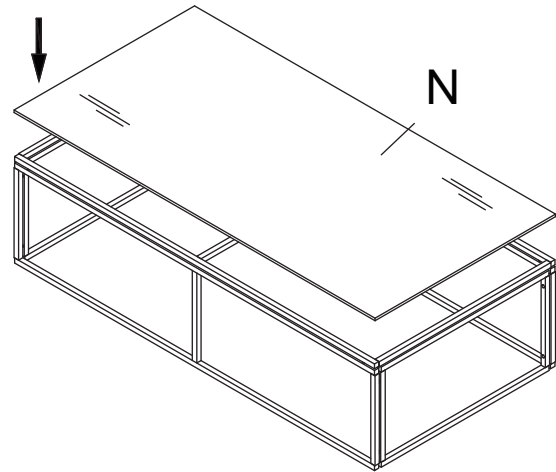

Never tilt the Chair during use.
Ensure the product is always placed firmly on the ground.

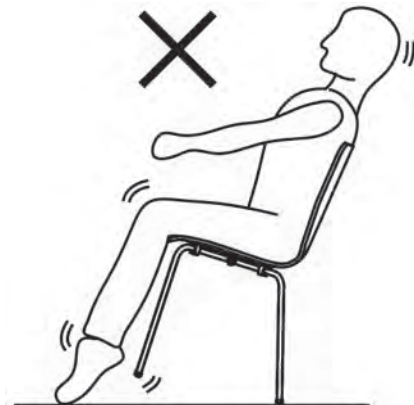

Ensure the product is always placed firmly on the ground.

PLEASE KEEP THESE INSTRUCTIONS FOR FUTURE REFERENCE