

Product Reference Size:
Dia230*H220 cm



The intended use of this product is for domestic use only.

Important, please retain for future reference.

Read carefully.

www.royalcraft.co.uk

Before you start

Warnings

See enclosed instructions for assembly, safety and care information.

Failure to follow the warnings could result in serious injury.

Handle heavy parts with care.

Ensure that this product is fully assembled as illustrated before use.

This product is intended for **domestic use** only.

This product should only be used on firm, level ground.

The product contains small parts which could pose a risk to young children. Keep small parts out of reach of children.

Keep hands away from folding mechanism and moving parts to prevent possible injury.

Never use or open this parasol without a suitable base set in place.

Furniture can be dangerous if incorrectly used. No liability will be accepted for damage or injury caused by incorrect use of this product.

Dos

When you are ready to start, make sure that you have the right tools, plenty of space and a clean, dry area for assembly.

Unwrap all packaging materials and place the components on suitable surface to prevent scratching your product.

Check all contents are present prior to assembly as per the parts list provided. In the event of problems or missing parts, please contact the seller.

Check all screws and bolts are tightened and inspect regularly.

Use a furniture cover to protect your product when not in use.

Ensure your item is closed when not in use.

During severe weather conditions, including high winds, rain, hail, thunderstorms, extreme heat and cold temperatures, the product should be taken down and stored inside in a cool, dry place.

Ensure that the product is clean and dry before storage.

Wipe with a damp sponge and a little warm soapy water, then dry with a clean, dry cloth. The product must be thoroughly dry to prevent mildew and mold stains from forming.

Where instructions as to the; storage, commissioning, installation, use and maintenance of the goods or (if there is none) good trade practice are not followed and a defect arises this will void the 12 month manufacturer's guarantee on the product.

Don'ts

Do not stand or climb onto the product.

Do not use power tools to construct this product.

Do not sit or lean on the rims of this product.

Do not use this product if parts are missing, damaged or worn.

Do not leave the parasol open when not in use or unattended.

Do not leave the parasol up or open when there is a risk of high winds, as damage will occur to its structure.

Do not use scourers, abrasives, washing powders, chemical cleaners or any other substances containing abrasives since these substances can damage the product.

Do not use solvent-based cleaners or detergents as they can bleach or damage the product.

Never use a pressure hose or washer to clean the product.

Never drag furniture when moving it, always lift it

Never move this parasol when fully assembled.

To avoid damage do not allow water to collect or "pool" on the fabric.

Do not over crank when opening and closing the parasol to prevent breakage of the mechanism.

Number of people required for assembly

One person





Time to assemble

5 Minutes

Tools required

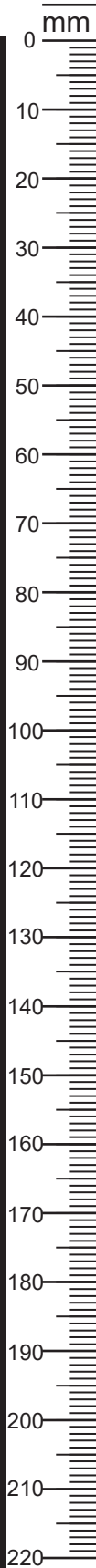
None



Parts List					
Part No.	Diagram	Qty.	Part No.	Diagram	Qty.
A		1 PC	B		1 PC
	Main Parasol Part			bottom Pole	

Assembly and Usage Steps

1. Press the Spring Pin and insert the Bottom Pole (B) into the Main Parasol Part (A);
2. Place the parasol at the intended place for use; Ensure a suitable base (not provided) is used.
3. Rotate the Crank clockwise to spread the parasol canopy;
4. The parasol is closed by reversing above steps.

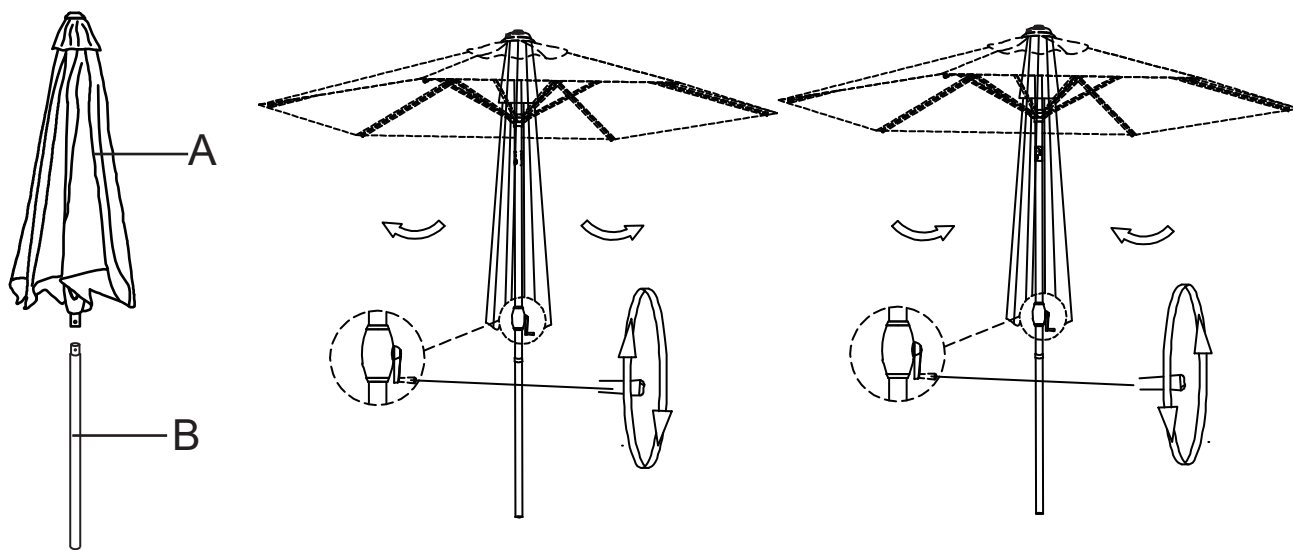

WARNING
Please take care to keep fingers away from moving parts and crank rotating area to prevent possible injury.

Note: The diagrams are for reference only.

A suitable parasol based should be used together with this parasol!

PLEASE KEEP THESE INSTRUCTIONS FOR FUTURE REFERENCE