

Product size:
L208*W122*H178cm



The intended use of this product is for domestic use only.

Important, please retain for future reference.

Read carefully.

3 Seat Swing Hammock

Assembly Instructions

Before you start



Warnings

IMPORTANT, RETAIN FOR FUTURE REFERENCE READ CAREFULLY

See enclosed instructions for assembly, safety and care information.

Failure to follow the warnings could result in serious injury.

Handle heavy parts with care.

Ensure that this product is fully assembled as illustrated before use.

This product should only be used on firm, level ground.

Keep small parts out of reach of children.

This product is intended for **domestic use** only.

Ensure the product is always placed on level ground.

Furniture can be dangerous if incorrectly used. No liability will be accepted for damage or injury caused by incorrect use of this product.



Dos

When you are ready to start, make sure that you have the right tools, plenty of space and a clean, dry area for assembly.

Unwrap all packaging materials and place the components on a suitable surface to prevent scratching your product.

Check all contents are present prior to assembly as per the parts list provided. In the event of problems or missing parts, please contact the seller.

Check all screws and bolts are tightened and inspect regularly.

Cover furniture when not in use to add additional protection to your product.

Frames are manufactured using powder coated aluminum tubing. Any scratches on the paintwork should be touched up immediately with metal paint to prevent corrosion.

During severe weather conditions, including high winds, rain, hail, thunderstorms, extreme heat and cold temperatures, the product should be stored inside in a cool, dry place.

To best preserve this product, please use a protective cover when your furniture is not in use. We would also recommend using a gazebo or parasol over your furniture during the summer period and prolonged sunny spells. This will help prevent harmful UV rays from damaging and discolouring the material.

Ensure that the product is clean and dry before storage.

Clean your product with a sponge and warm soapy water then wipe with a clean, dry cloth.

This product is suggested to be assembled at the place of use.

Where instructions as to the storage, commissioning, installation, use and maintenance of the goods or if there is none good trade practice are not followed and a defect arises this will void the 12 month manufacturer's guarantee on the product.



Don'ts

Do not stand or climb onto the product.

Do not use power tools to construct this product.

Do not sit or lean onto the rims of this product.

Do not use this product if parts are missing, damaged or worn.

Never use scourers, abrasives or chemical cleaner.

Do not use this product as a ladder as this could lead to the product becoming unbalanced and overturning.

Do not place very hot or very cold items on this product surface.

Never drag furniture when moving it, always lift it.

Don't tilt/sway the swing backwards and forwards violently!

Number of people required for assembly

Two people



Time to assemble



50 minutes















Tools required



3 Seat Swing Hammock

Assembly Instructions

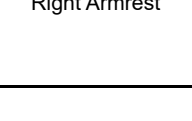
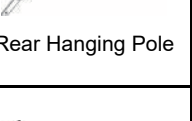
Components, fixtures & fittings (not actual size)



















Parts List								
Part No.	Diagram	Qty (pcs)	Part No.	Diagram	Qty (pcs)	Part No.	Diagram	Qty (pcs)
1	 Front Leg	2 PCS	2	 Rear Leg	2 PCS	3	 Top Cross Bar	1 PC
4	 Rear Cross Bar	1 PC	5	 Side Leg Brace	2 PCS	6	 Middle Cross Bar	1 PC
7	 Seating Panel	1 PC	8	 Backrest	1 PC	9	 Left Armrest	1 PC
10	 Right Armrest	1 PC	11	 Rear Hanging Pole	2 PCS	12	 Front Hanging Pole	2 PCS
13	 Canopy Cross Bar	2 PCS	14	 Side Canopy Brace	2 PCS	15	 M8*120mm	4 PCS



3 Seat Swing Hammock

Assembly Instructions

Parts List

Part No.	Diagram	Qty (pcs)	Part No.	Diagram	Qty (pcs)	Part No.	Diagram	Qty (pcs)
16	 M8*45mm	4 PCS	17	 M6*80mm	4 PCS	18	 M6*65mm	4 PCS
19	 M6*60mm	2 PCS	20	 M6*45mm	4 PCS	21	 M6*35mm	2 PCS
22	 M8 Nut	4 PCS	23	 M6 Nut	6 PCS	24	 M8 Washer	12 PCS
25	 M6 Washer	22 PCS	26	 M8 Bolt End Cap	8 PCS	27	 M6 Bolt End Cap	16 PCS
28	 M8 Nut Cap	4 PCS	29	 M6 Nut Cap	6 PCS	30	 Locking Knob	2 PCS
31	 Spring Hook	2 PCS	32	 Spanner	2 PCS	33	 Canopy	1 PC

3 Seat Swing Hammock

Assembly Instructions

Step by step assembly instructions

Note: Don't tighten nuts before every bolt is in place.

Don't tighten the nuts before all parts are aligned properly.

WARNING: At least two people should work together for easy assembly.

Step One

Attach the Front Legs (1) and Rear Legs (2) to each end of the Top Cross Bar (3). Secure them with Washers (24), Bolts (15) & Bolts End Caps (26), Nuts (22) & Nut Caps (28).

Tighten only enough to hold the parts in place. Do not tighten completely at this time. Some latter adjustments may be necessary to ensure the parts are aligned properly.

The Bolts End Caps and Nut Caps can only be attached when all Bolts and Nuts are tightened.

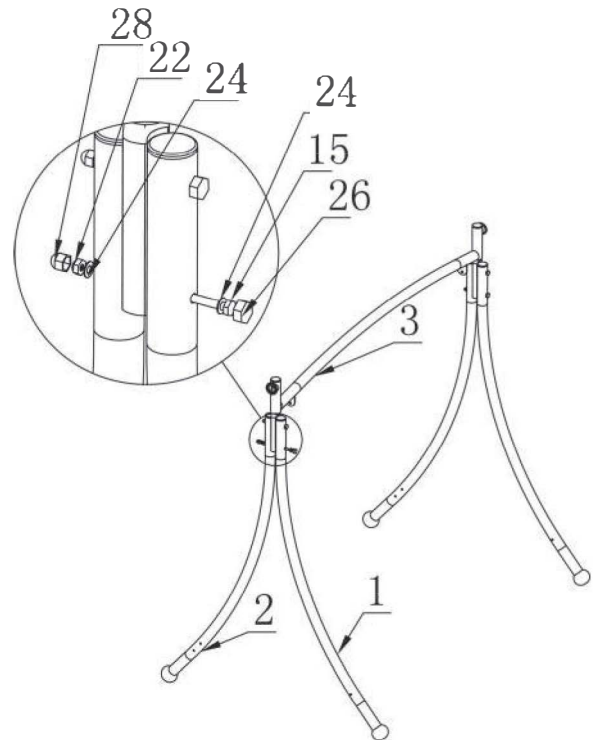

Step Two

Assemble the two Side Leg Braces (5) & Rear Cross Bar (4) to the Rear Legs (2); Secure them with Washers (25), Bolts (17) & Bolt End Caps (27), Nuts (23) & Nut Caps (29).

Please note the Rear Legs are placed between the Leg Braces (5) and Rear Cross Bar (4).

Assemble the front Part of the Side Leg Braces (5) to the Front Legs (1) using Washers (25), Bolts (19) & Bolt End Caps (27), Nuts (23) & Nut Caps (29).

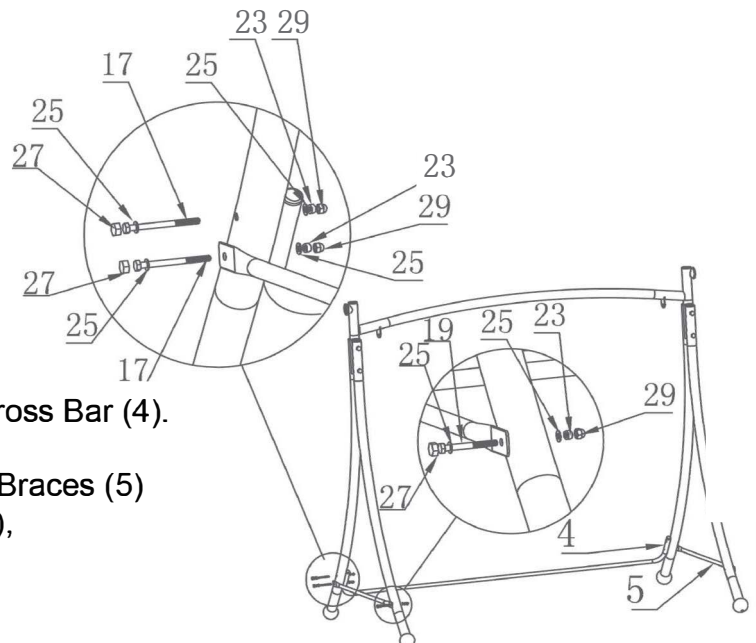

3 Seat Swing Hammock

Assembly Instructions

Step Three

Attach the Middle Cross Bar (6) to the two side Leg Braces (5) using Washers (25), Bolts (21) & Bolt End Caps (27).

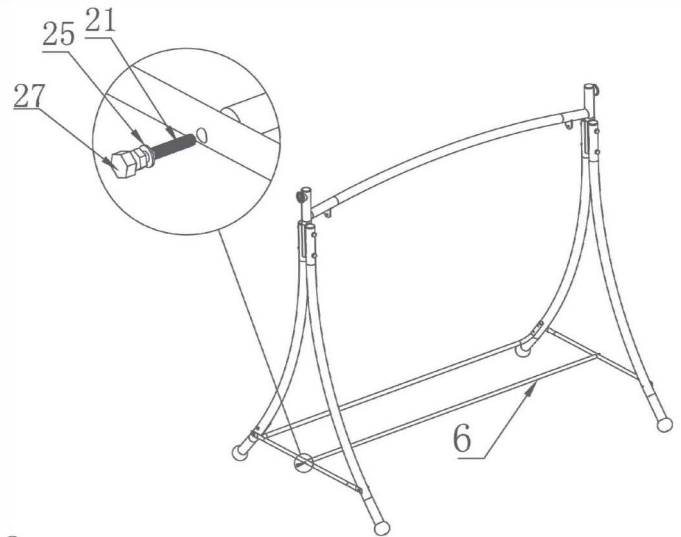

Step Four

Assemble the Backrest (8) to the Left Armrest (9) and Right Armrest (10) using Washers (25), Bolts (18) & Bolt End Caps (27).

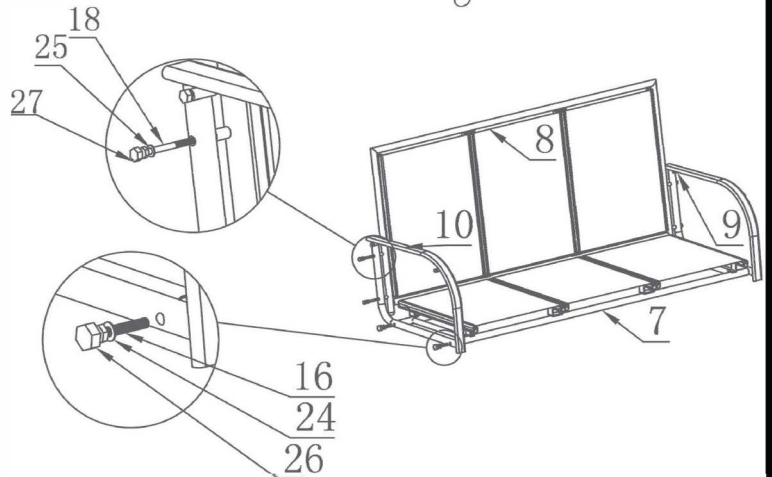

Assemble the Seating Panel (7) to the Left Armrest (9) and Right Armrest (10) using Washers (24), Bolts (16) & Bolt End Caps (26).

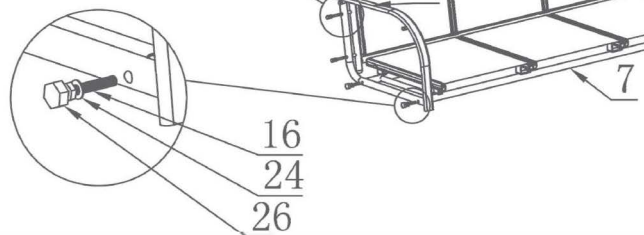

Step Five

Attach the Front Hanging Poles (12) & Rear Hanging Poles to the Armrests (9 & 10) using Washers (25), Bolts (20) & Bolt End Caps (27).

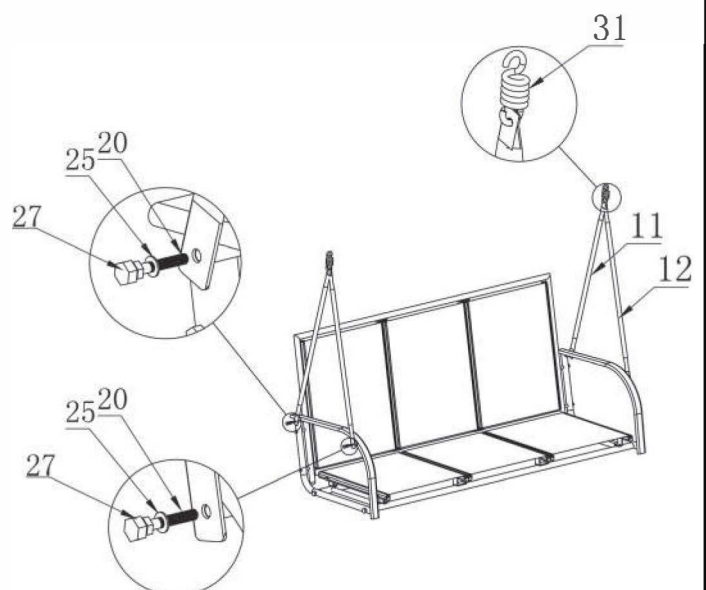

Attach Spring Hook (31) to the Hanging Poles (11 & 12).

3 Seat Swing Hammock

Assembly Instructions

Step Six

With two people holding the assembled seat, hang them to the pre-fitted Hanging Hook on the Top Cross Bar (3).



Step Seven

Attach the Canopy Brace (14) to each end of the Assembled Swing Frame using Knocking Knob(30).

Assemble the Canopy Cross Bar (13) to the Canopy Brace (14).

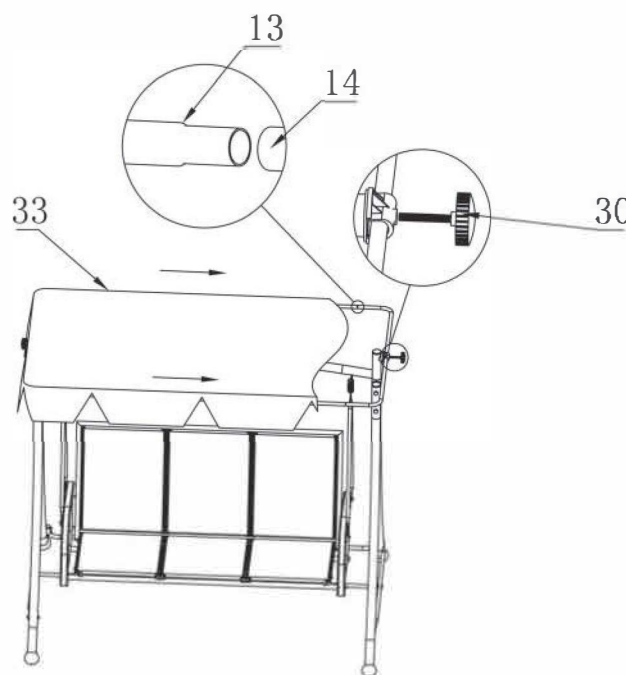

3 Seat Swing Hammock

Assembly Instructions

Step Eight

Attach the Canopy to the Swing Frame.

Your swing hammock is now ready for use.



Warning:
Children and Kids should not use this product
without adult supervision and presence.

PLEASE KEEP THESE INSTRUCTIONS FOR FUTURE REFERENCE