

PSpice Model

Power Factor Correction Controller

On Semiconductor

NCP1654BD65R2G

Model Information

Model A macro model
Call Name MDC_NCP1654BD65R2G_PS
Pin Assign 1:GND 2:VM 3:CS 4:BO 5:VCNT 6:FB 7:VCC 8:DRV
File List Model Library MDC_NCP1654BD65R2G_PS.lib
 Model Report MDC_NCP1654BD65R2G_PS.pdf(this file)
Verified Simulator Version PSpice 17.2
Note

References

The information which was used for modeling is as follow:

[Data Sheet]

- Date/Version March 2021 Rev. 6
- Product name NCP1654BD65R2G
- Company name ON Semiconductor

[Characteristics listed]

- Characteristics Roh, Rol, Tr, Tf, Vref
Is(ocp), Ics(opl1), Ics(opl2)
Dcycle, Fsw, Vboh, Vbol, Vcc(on), Vcc(off)

Simulation Condition

This table shows the range of evaluated simulation range that was not occurs any convergence problems in this area.

Item	Condition	Unit
Temperature	25	deg C

Model Functions Table

Functions	Implemented
Programmable Overcurrent Protection	○
Brown-Out Detection	○
Overvoltage Protection	○
Soft Start	○
Continuous Conduction Mode	○
Average Current-Mode or Peak Current-Mode Operation	○
Programmable Overpower Limitation	○
Undervoltage Detection for Open Loop Detection (shutdown)	○
Inrush Currents Detection	○

Power Factor Correction (CCM) Testbench (Vrms=100[V] Vout=390[V] Iout=0.77[A])

Referred to Data Sheet

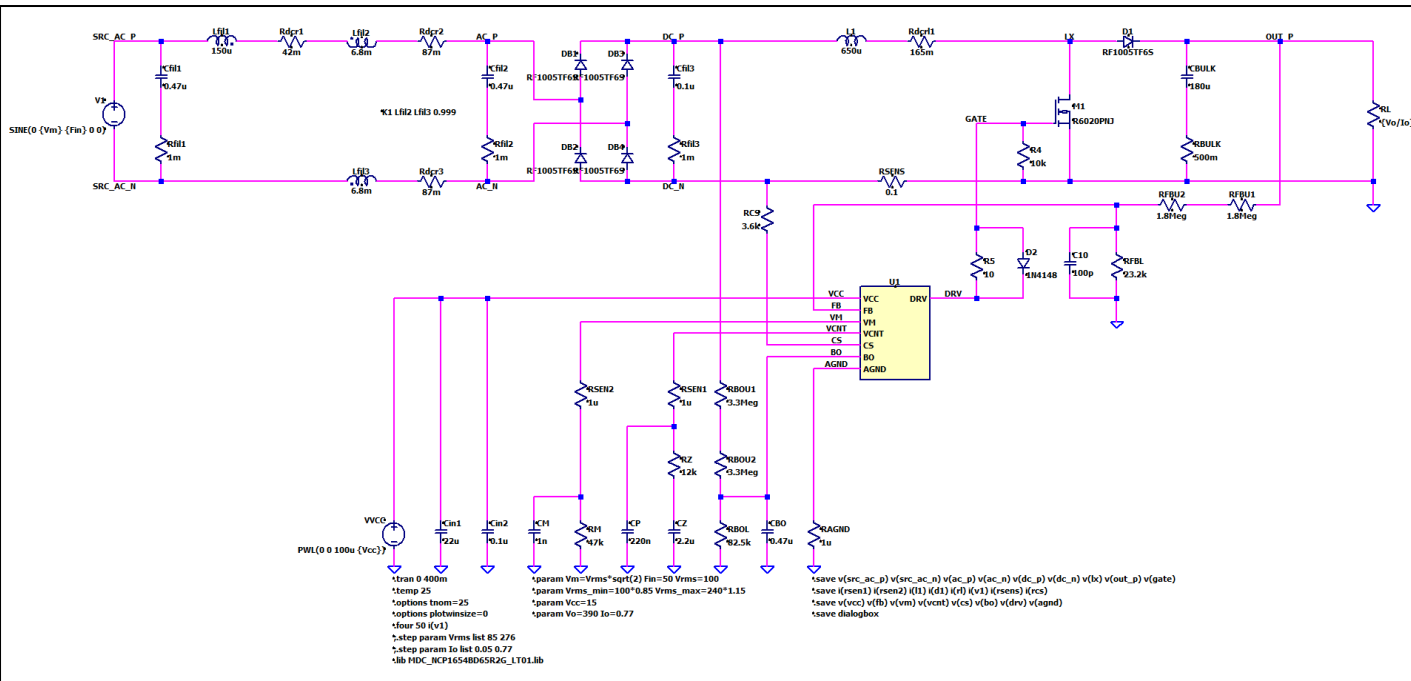

Simulation results are following.
Explanatory notes — : simulated

Power Factor Correction (CCM) Testbench (Vrms=100[V] Vout=390[V] Iout=0.77[A])

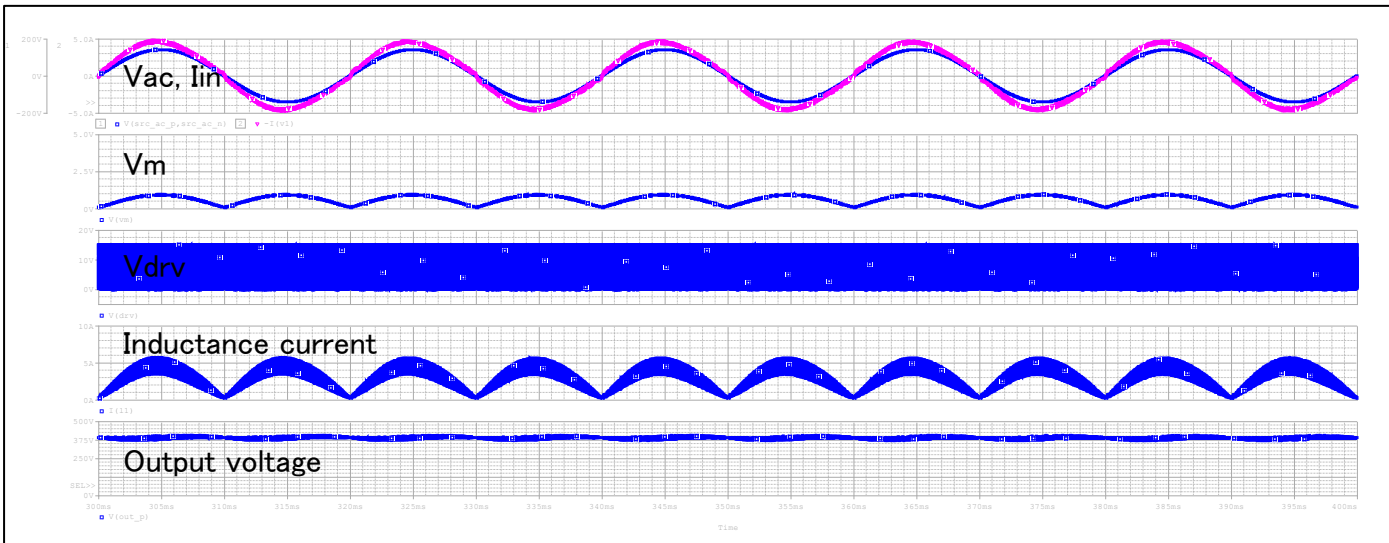

Simulation results are following.
Explanatory notes — : simulated

Brown-out Testbench (Vrms=100[V] Vout=390[V] Iout=0.77[A])

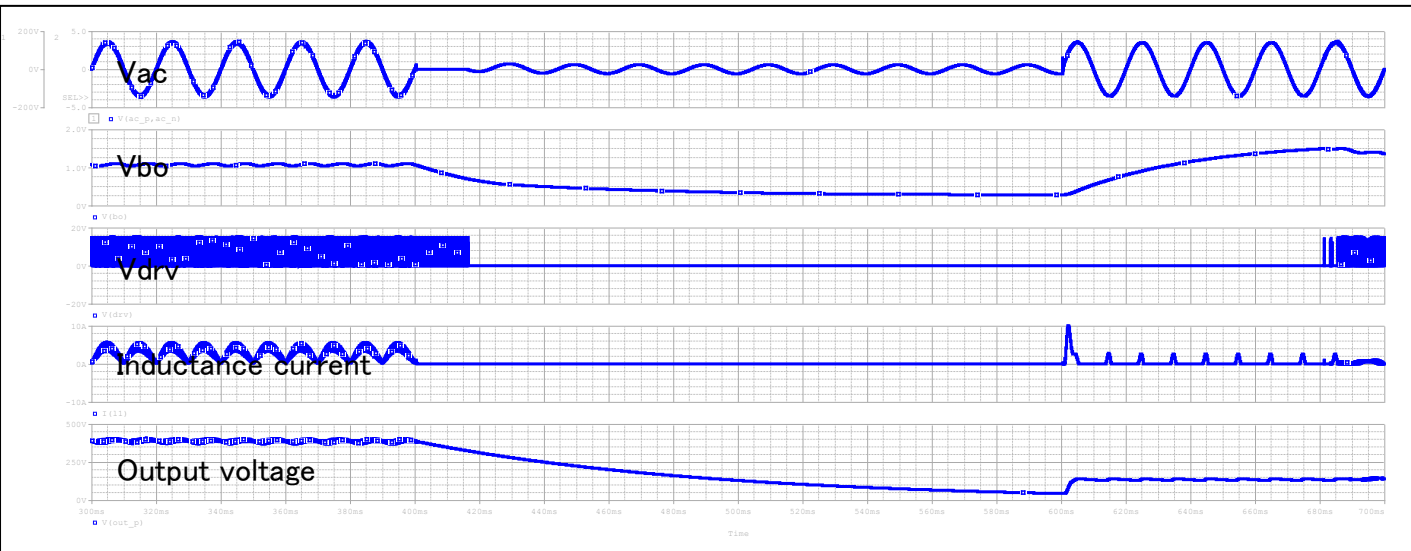

Vcc UVLO Testbench (Vrms=100[V] Vout=390[V] Iout=0.77[A])

Referred to Data Sheet

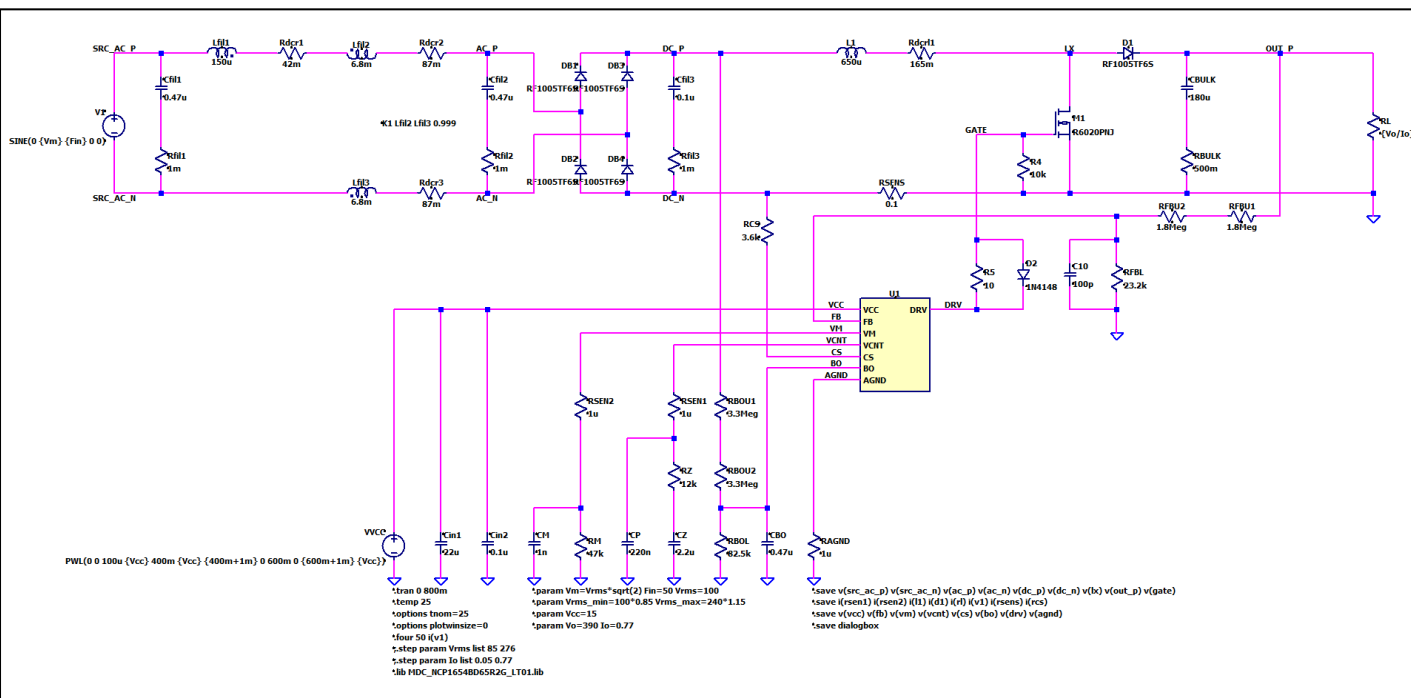

Simulation results are following.
Explanatory notes — : simulated

Brown-out Testbench (Vrms=100[V] Vout=390[V] Iout=0.77[A])

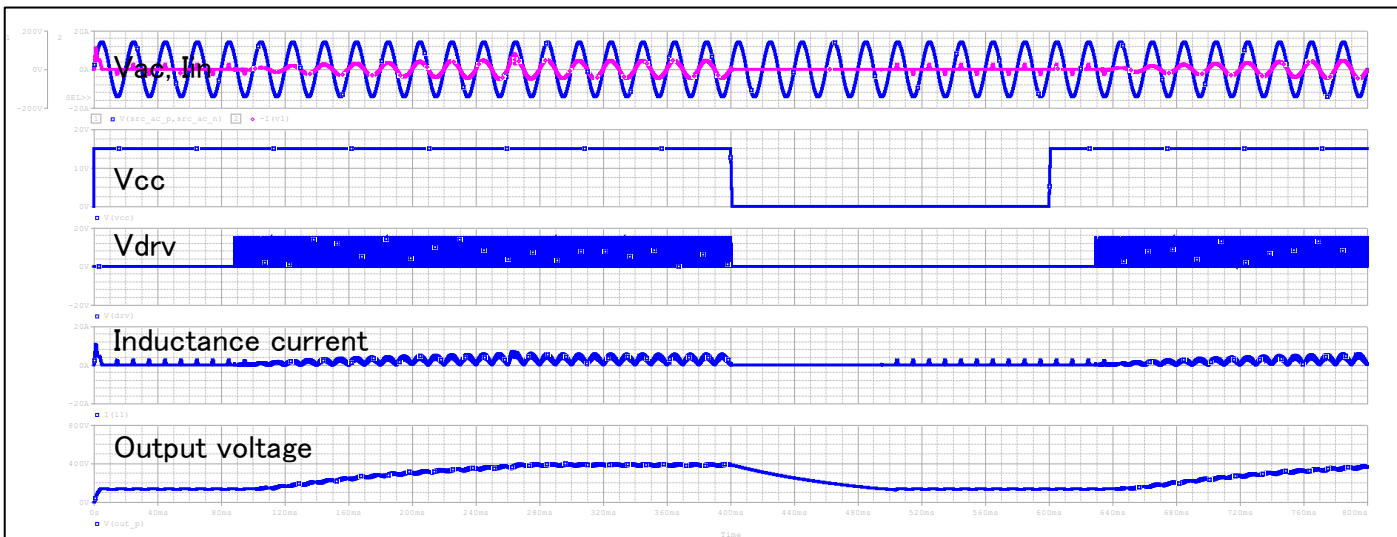

DISCLAIMER

1. This SPICE (Simulation Program with Integrated Circuit Emphasis) model and its content (the "Contents") are copyright of MoDeCH Inc. All rights reserved. Any redistribution or reproduction of any or all part of the Contents in any form is prohibited without express written permission made by MoDeCH Inc.
2. MoDeCH Inc. as licensor (the "Licensor") hereby grants to you, as licensee (the "Licensee"), a non-exclusive, non-transferable license to use the Contents as long as you abide by the terms and conditions of this DISCLAIMER.
3. The Licensee is not authorized to sell, loan, rent and redistribute or license the Contents in whole or in part, or in modified form, to anyone.
4. The Licensor shall in no way be liable to the Licensee or any third party for any loss or damage (including ,but not limited to, lost profits, or other incidental, consequential, or punitive damages), however caused (including through negligence) which may be directly or indirectly suffered from, arising out of, or in connection with, any use of the Contents .
5. Notwithstanding anything contained in this DISCLAIMER, in no event shall Licensor be liable for any claims, damages or loss which may arise from the modification, combination, operation or use of the Contents with the Licensee's computer programs.
6. The Licensor does not warrant that the Contents will function in any environment.
7. The Contents may be changed or updated without notice. MoDeCH Inc. may also make improvements and/or changes in the products, pricing and/or the programs related to the Contents at any time without notice.



MoDeCH Inc.

Head Office

Location: 5-15 Yokoyama-cho, Hachioji-Shi, Tokyo 192-0081, Japan

Tel:+81-42-656-3360

E-Mail:model-on-support@modech.co.jp

URL:<http://www.modech.com/en/>