

LTspice Model

Intelligent Power Module

MITSUBISHI ELECTRIC Corporation

PSS75SA2FT

Model Information

Model	A macro model
Call Name	MDC_PSS75SA2FT_LT
Pin Assign	1:UP 2:NC_1 3:VP1_1 4:VUFB 5:NC_2 6:VUFS 7:VP 8:NC_3 9:VP1_2 10:VVFB 11:NC_4 12:VVFS 13:WP 14:VP1_3 15:VPC 16:VWFB 17:NC_5 18:VWFS 19:VSC 20:NC_6 21:VN1 22:VNC 23:VOT 24:CIN 25:CFO 26:FO 27:UN 28:VN 29:WN 30:NC_7 31:NC_8 32:NC_9 33:NC_10 34:NW 35:NV 36:NU 37:W 38:V 39:U 40:P 41:NC_11 42:NC_12
File List	Model Library MDC_PSS75SA2FT_LT01.lib Model Report MDC_PSS75SA2FT_LT.pdf(this file)

Verified Simulator Version LTspice version XVII

Note

References

The information which was used for modeling is as follow:

[Data Sheet]

- Date/Version 2020.2
- Product name PSS75SA2FT
- Company name MITSUBISHI ELECTRIC Corporation

[Characteristics listed]

- Characteristics Switching time(P-side)
Switching time(N-side)
UVLO(P-side)
UVLO(N-side)
Three-phase AC output(reference data)

Simulation Condition

This table shows the range of evaluated simulation range that was not occurs any convergence problems in this area.

Item	Condition	Unit
Temperature	25	deg C

Model Functions Table

Functions	Implemented
Collector-emitter saturation voltage	<input type="radio"/>
FWD forward voltage drop	<input type="radio"/>
Switching time	<input type="radio"/>
UVLO(P-side)	<input type="radio"/>
UVLO(N-side)	<input type="radio"/>
Input ON / OFF threshold voltage	<input type="radio"/>

Switching time(P-side) Testbench

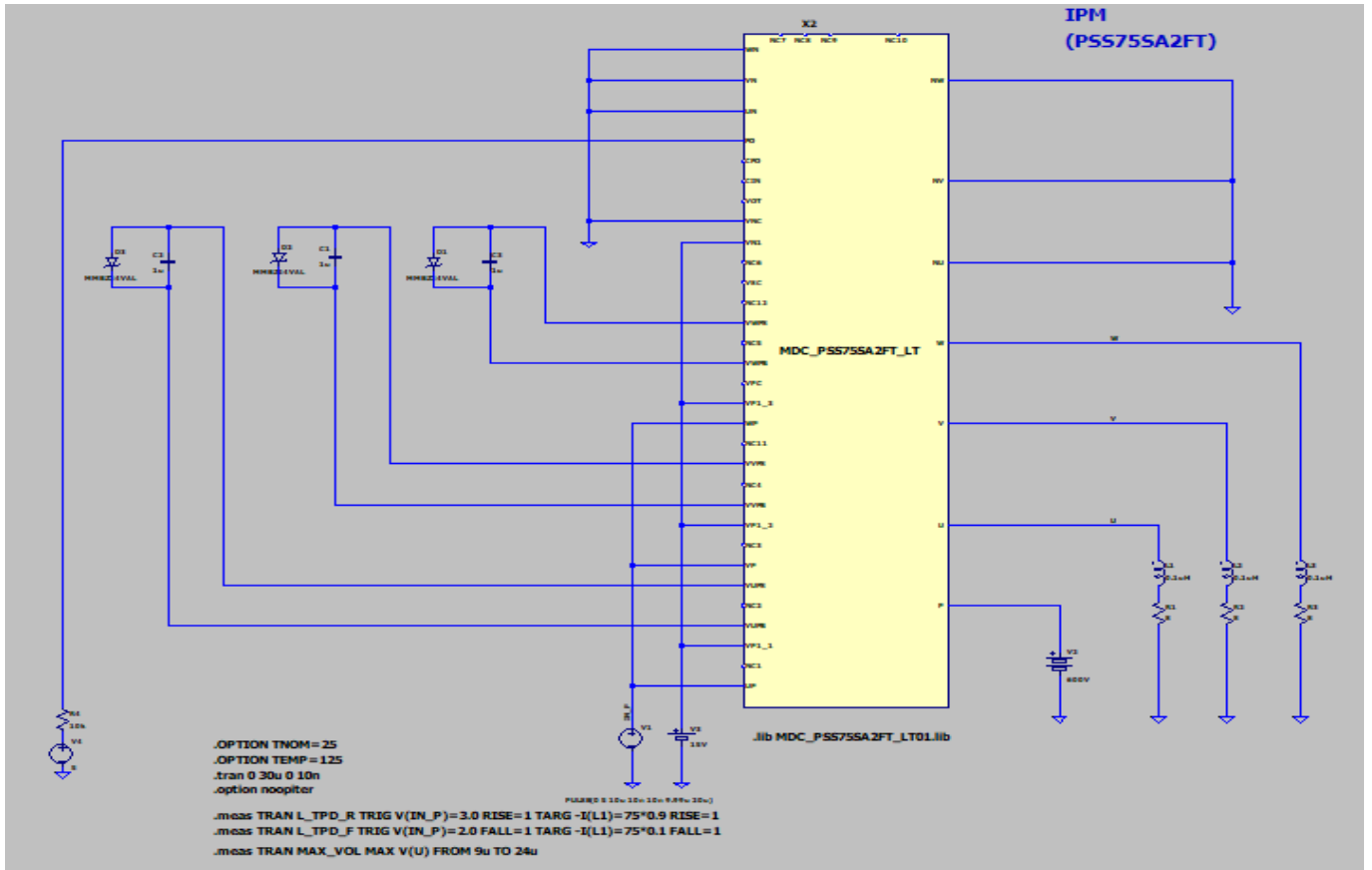

Simulation results are following.
 Explanatory notes — : simulated

Switching time(P-side)

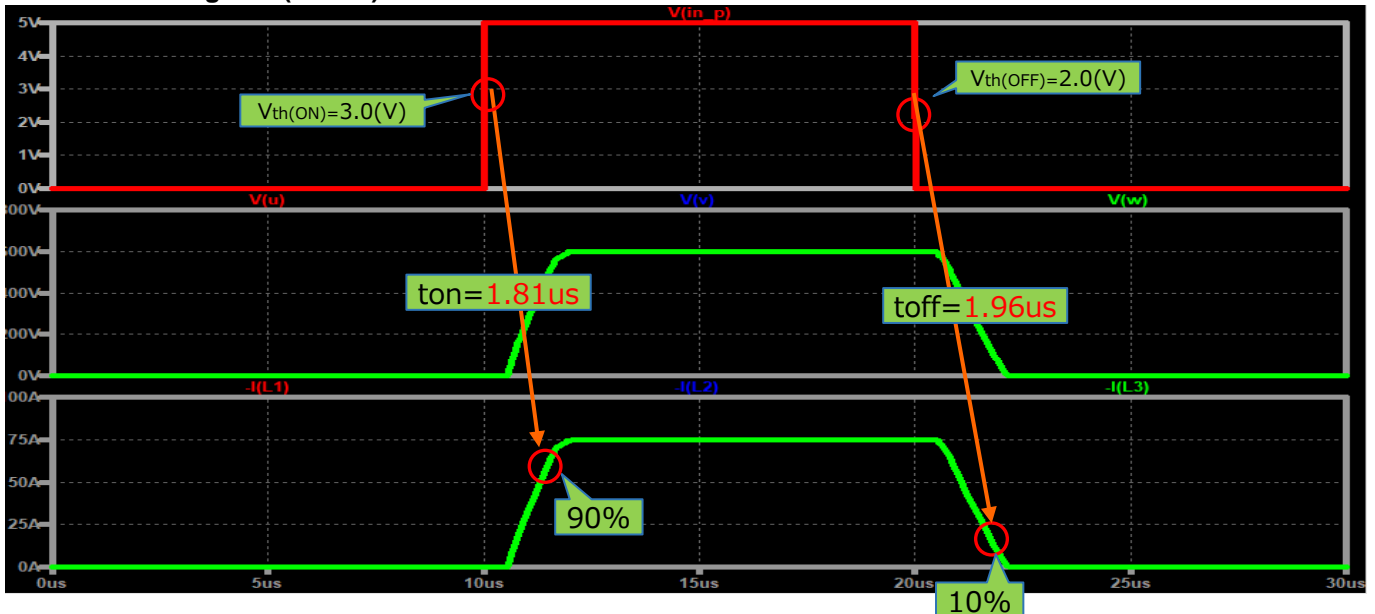

Switching time(N-side) Testbench

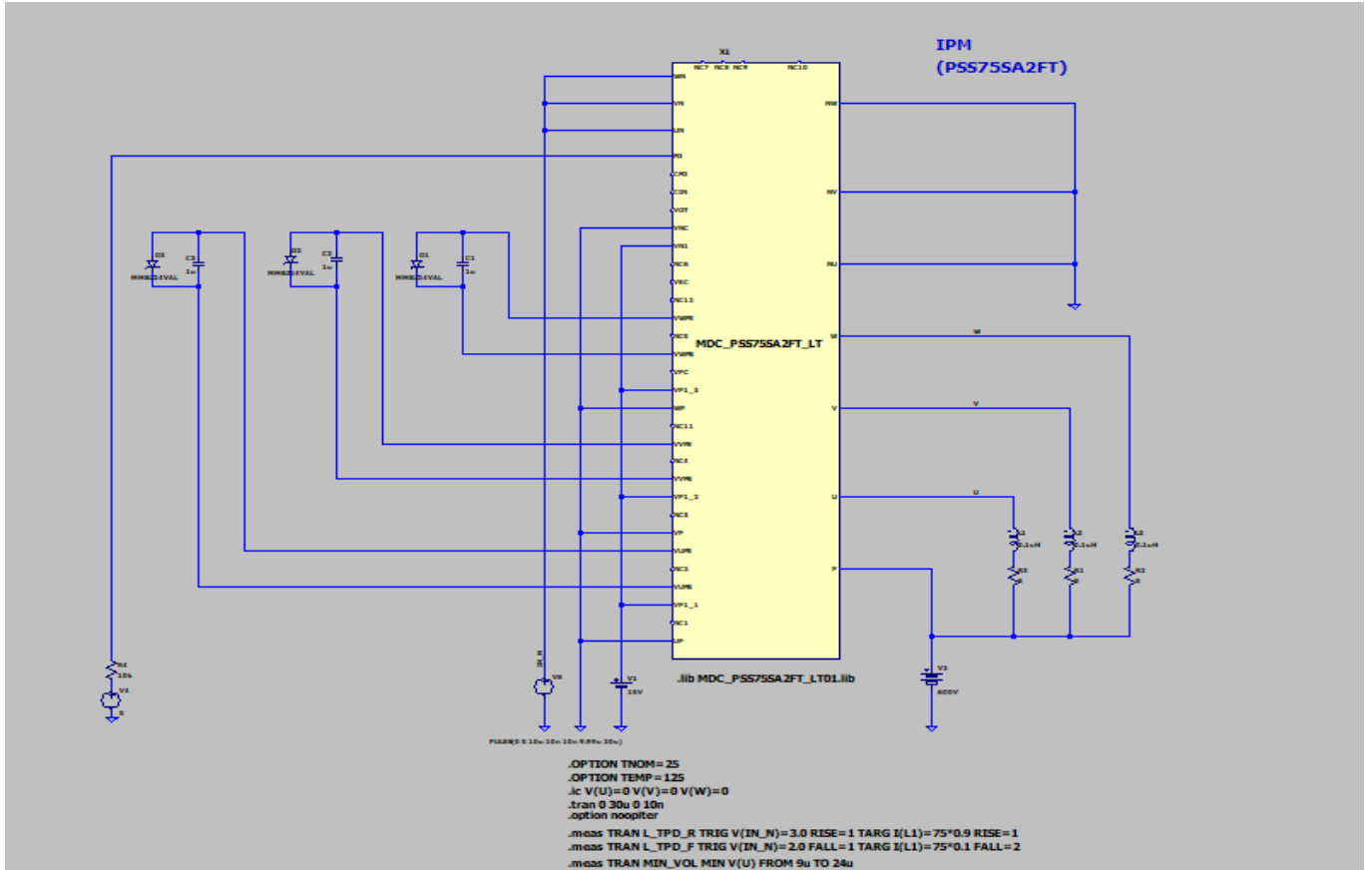

Simulation results are following.
 Explanatory notes — : simulated

Switching time(N-side)

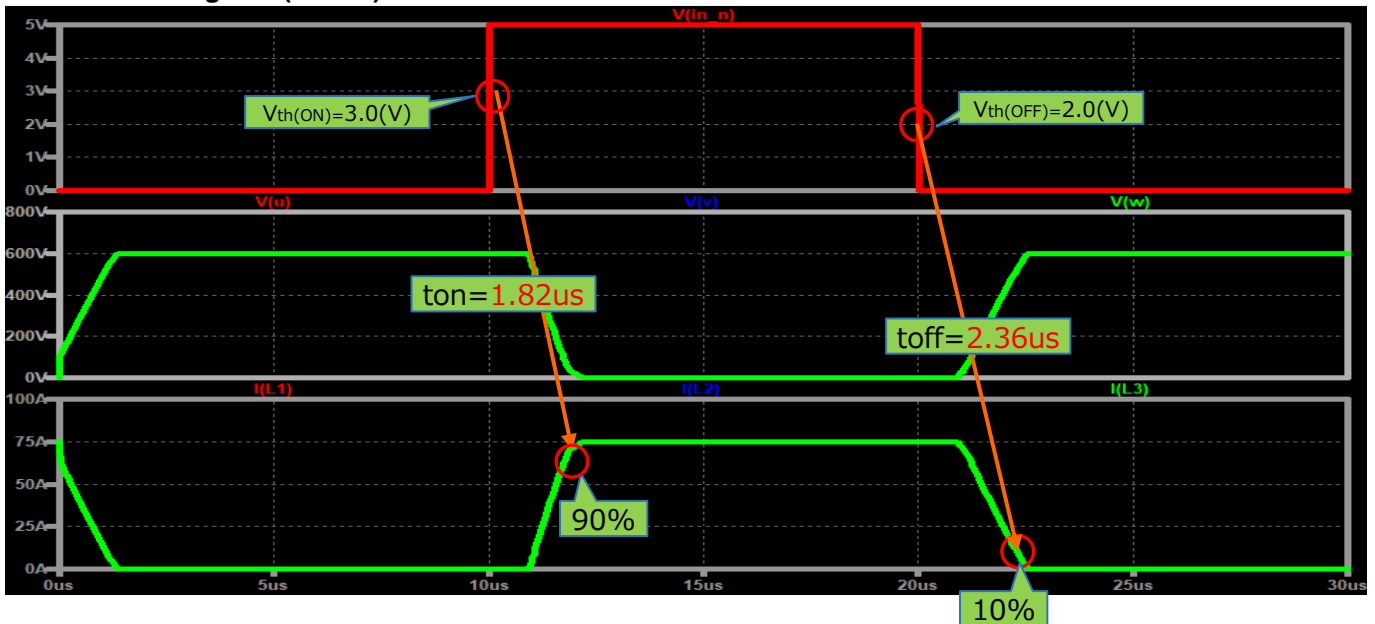

UVLO(P-side) Testbench

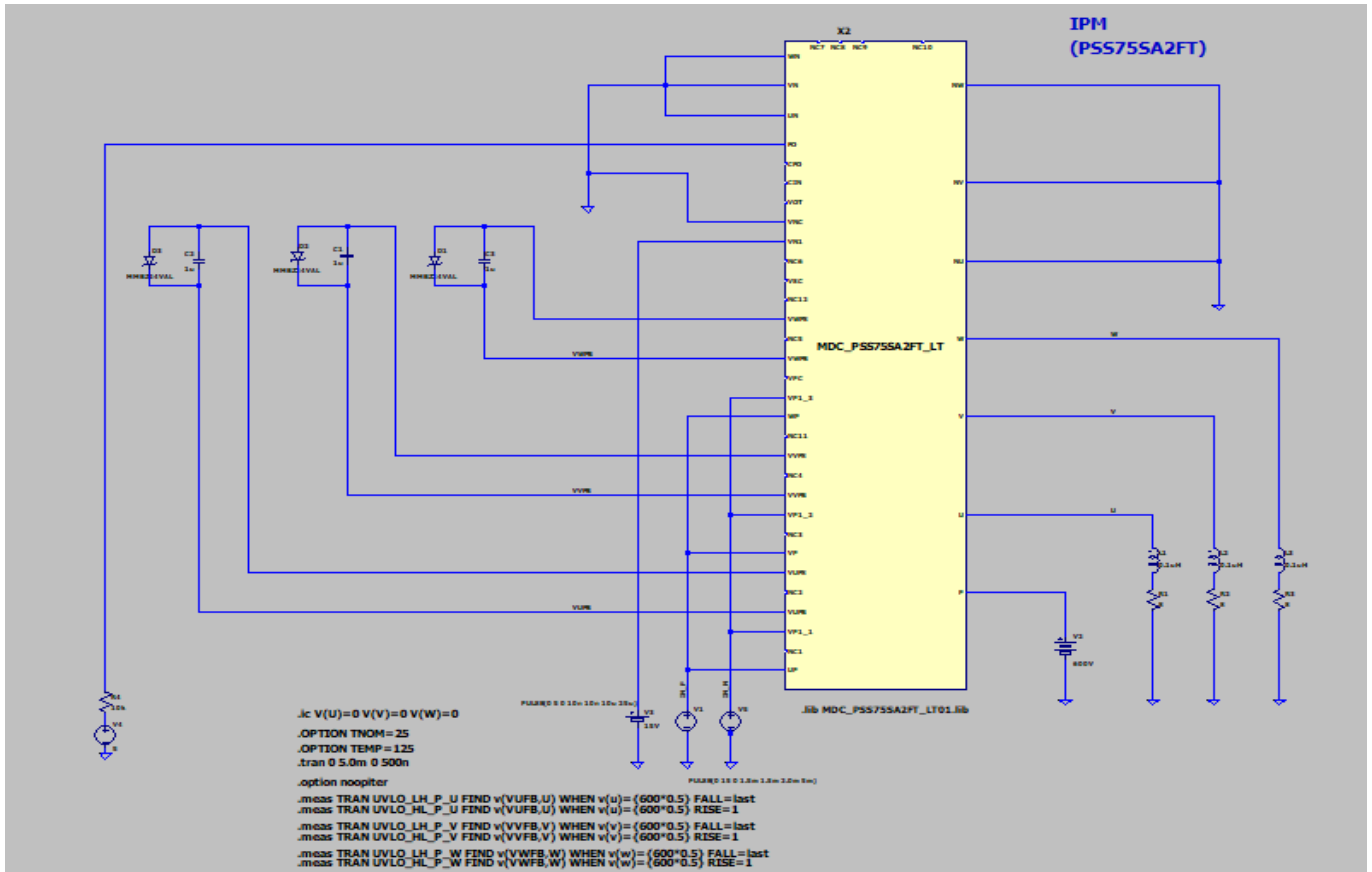

Simulation results are following.
 Explanatory notes — : simulated

UVLO(P-side)

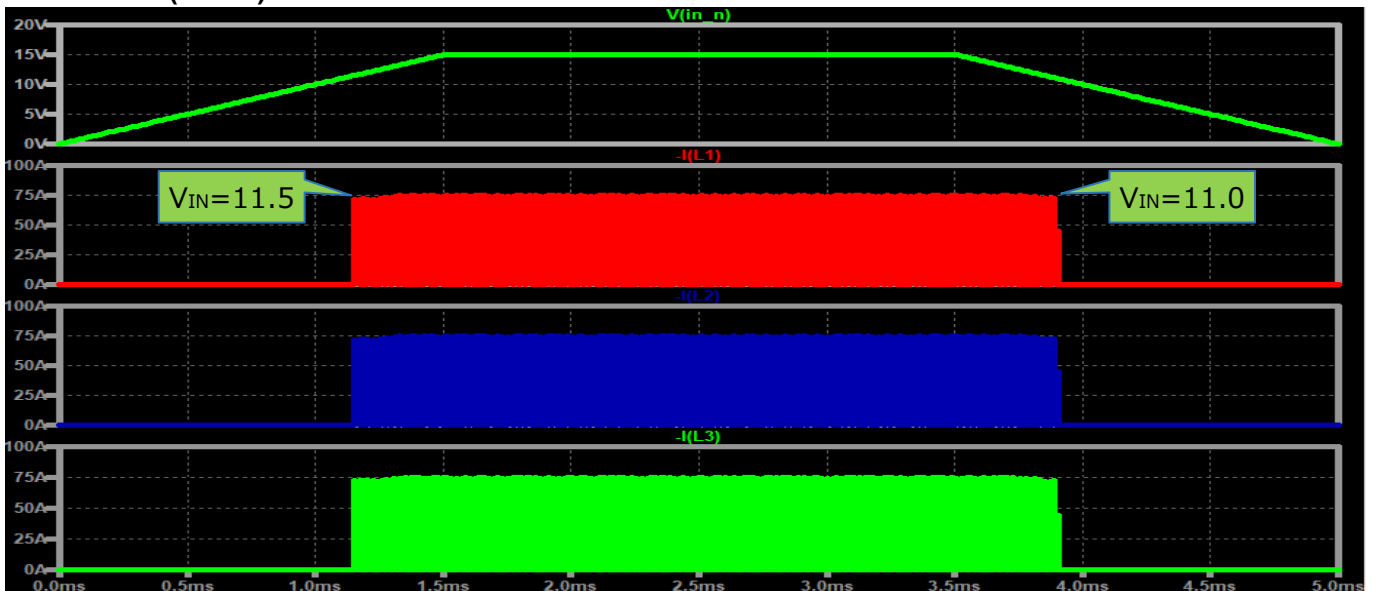

UVLO(N-side) Testbench

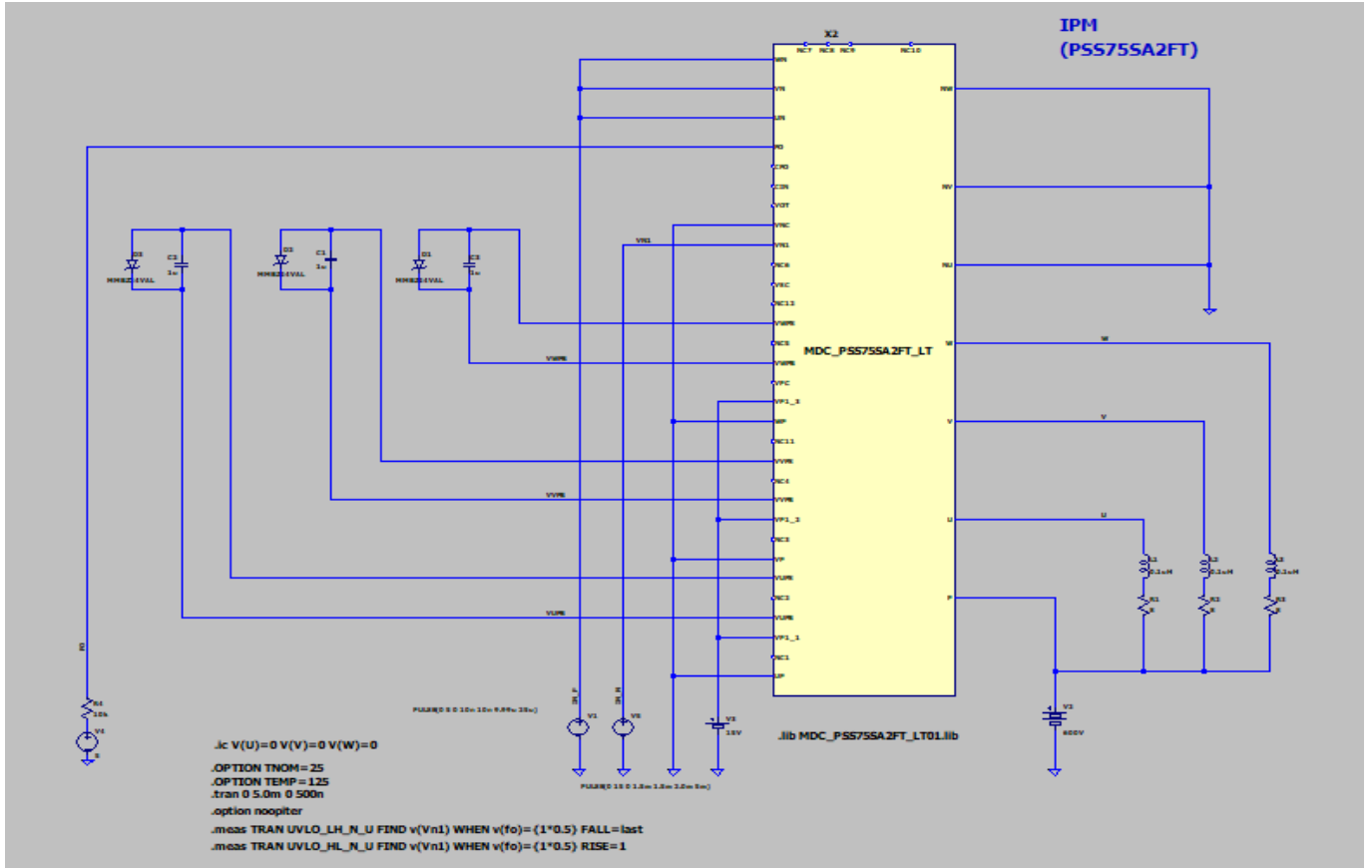

Simulation results are following.
 Explanatory notes — : simulated

UVLO(N-side)

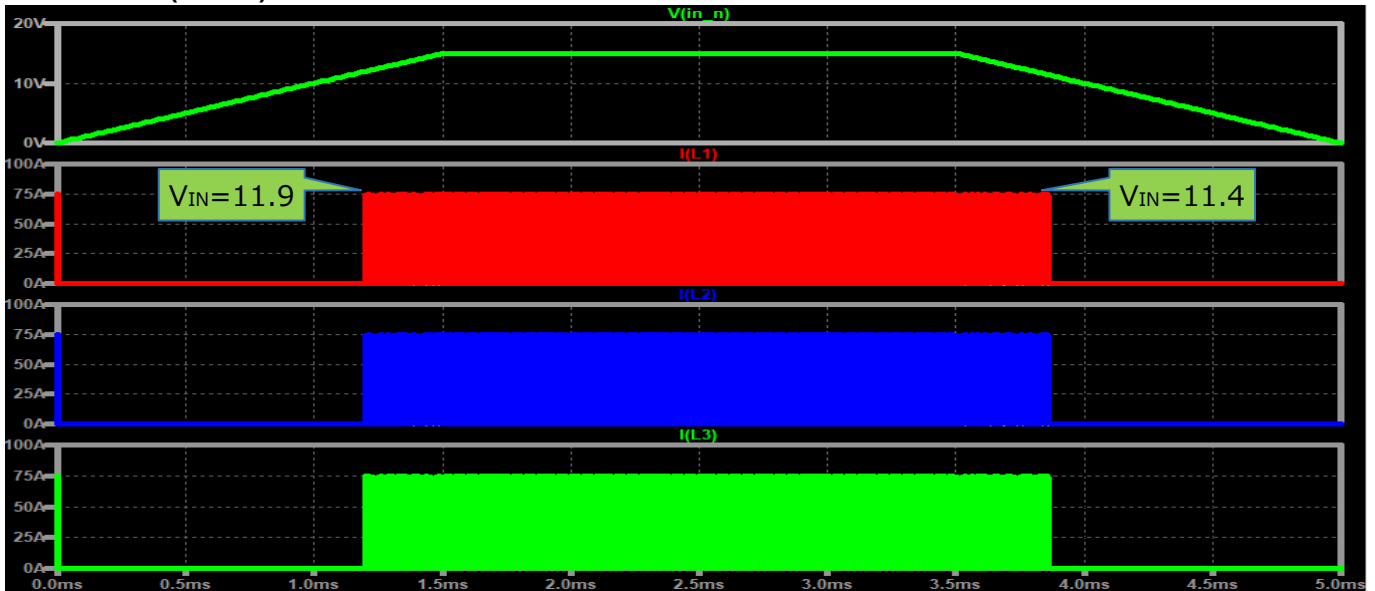

Three-phase AC output (reference data) Testbench

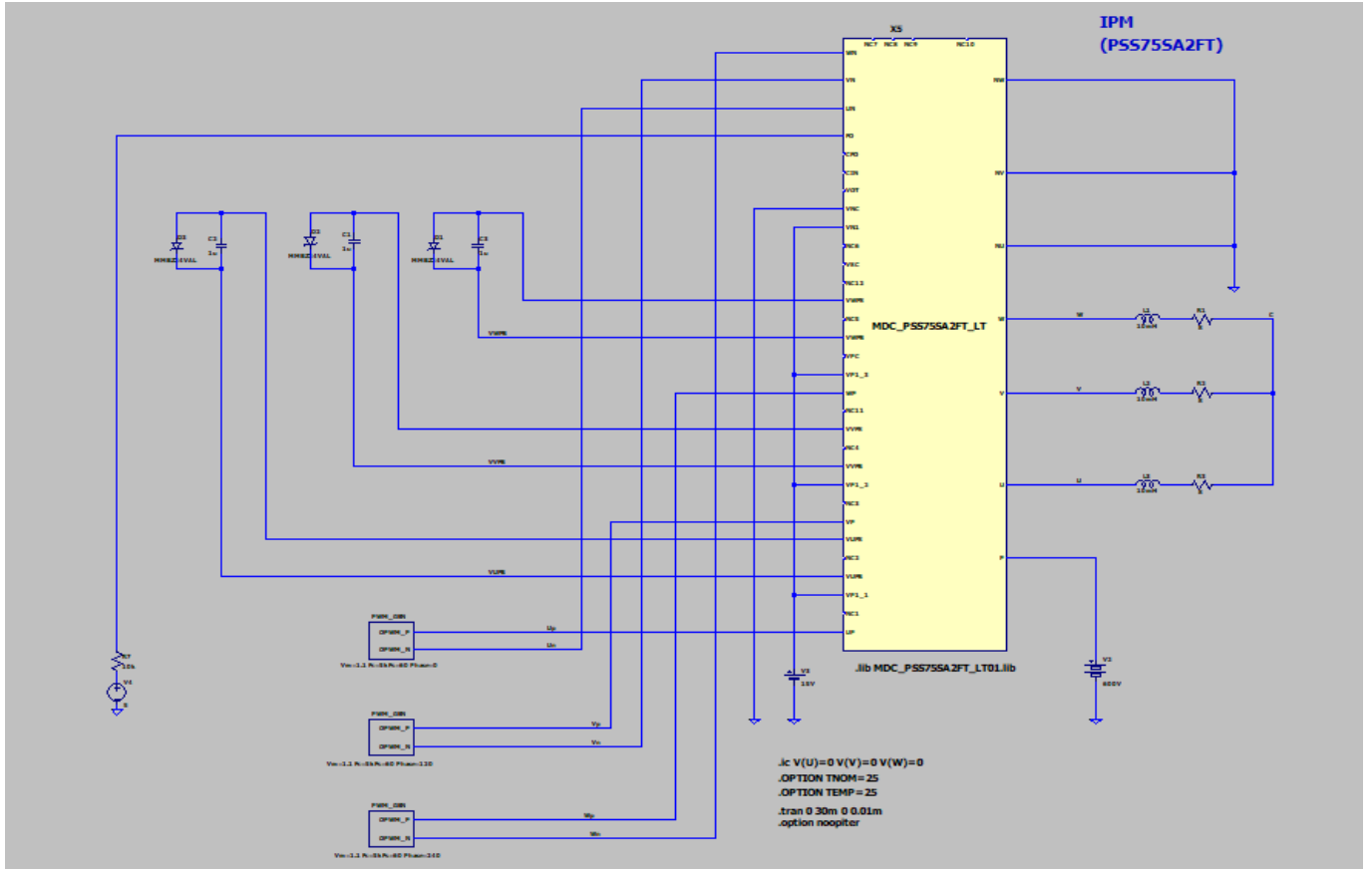

Three-phase AC output (reference data)

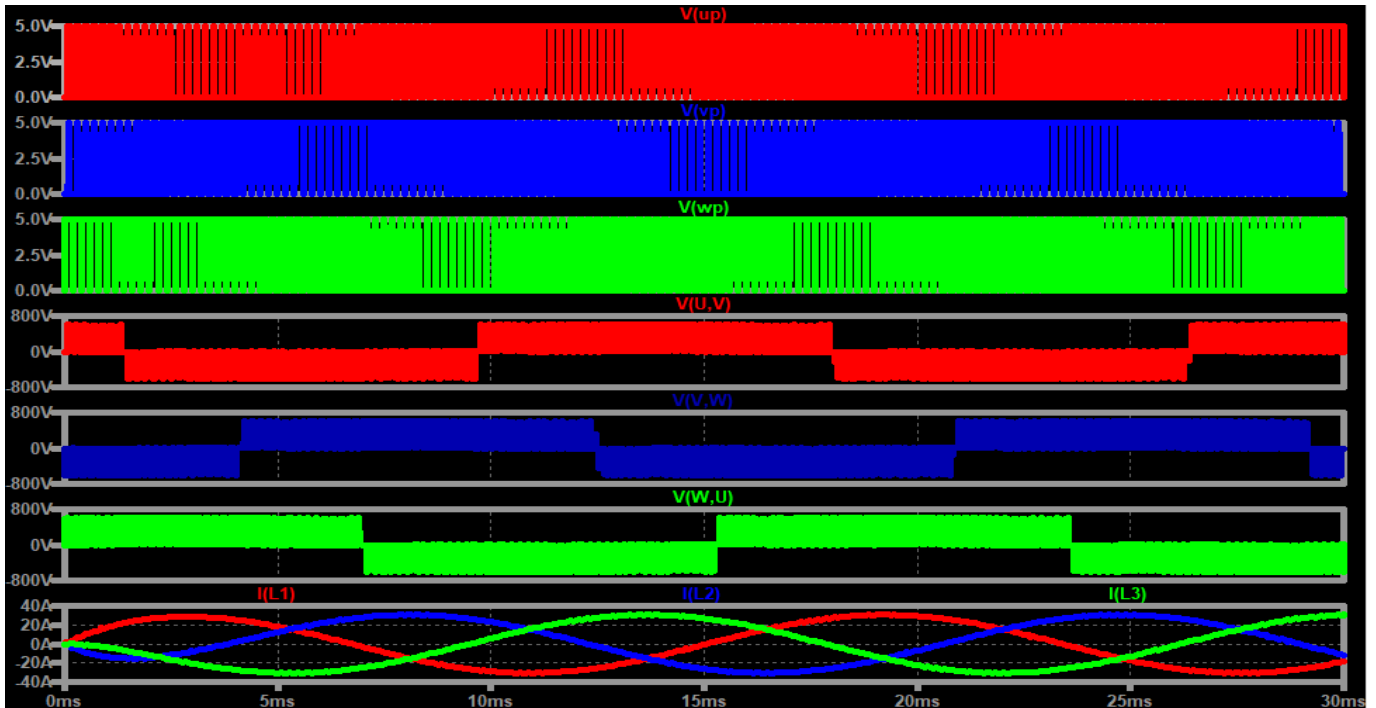

DISCLAIMER

1. This SPICE (Simulation Program with Integrated Circuit Emphasis) model and its content (the "Contents") are copyright of MoDeCH Inc. All rights reserved. Any redistribution or reproduction of any or all part of the Contents in any form is prohibited without express written permission made by MoDeCH Inc.
2. MoDeCH Inc. as licensor (the "Licensor") hereby grants to you, as licensee (the "Licensee"), a non-exclusive, non-transferable license to use the Contents as long as you abide by the terms and conditions of this DISCLAIMER.
3. The Licensee is not authorized to sell, loan, rent and redistribute or license the Contents in whole or in part, or in modified form, to anyone.
4. The Licensor shall in no way be liable to the Licensee or any third party for any loss or damage (including ,but not limited to, lost profits, or other incidental, consequential, or punitive damages), however caused (including through negligence) which may be directly or indirectly suffered from, arising out of, or in connection with, any use of the Contents .
5. Notwithstanding anything contained in this DISCLAIMER, in no event shall Licensor be liable for any claims, damages or loss which may arise from the modification, combination, operation or use of the Contents with the Licensee's computer programs.
6. The Licensor does not warrant that the Contents will function in any environment.
7. The Contents may be changed or updated without notice. MoDeCH Inc. may also make improvements and/or changes in the products, pricing and/or the programs related to the Contents at any time without notice.



MoDeCH Inc.

Head Office

Location: 5-15 Yokoyama-cho, Hachioji-Shi, Tokyo 192-0081, Japan

Tel:+81-42-656-3360

E-Mail:model-on-support@modech.co.jp

URL:<http://www.modech.com/en/>