

# LTspice Model

## Full-Bridge DC Motor Driver IC

### TOSHIBA

### TB6642FTG

#### Model Information

**Model** An original macro model  
**Call Name** MDC\_TB6642FTG\_LT  
**Pin Assign** 1:OUT1 2:OUT1 3:NC 4:RSGND 5:RSGND 6:NC 7:OUT2 8:OUT2 9:NC 10:NC 11:VM 12:VM 13:NC 14:NC 15:VSD 16:NC 17:TSD 18:PWM 19:NC 20:NC 21:NC 22:ALERT 23:OSC 24:IN1 25:NC 26:SGND 27:SGND 28:NC 29:NC 30:NC 31:IN2 32:NC  
**File List** Model Library MDC\_TB6642FTG\_LT01.lib  
 Model Report MDC\_TB6642FTG\_LT.pdf (this file)

**Verified Simulator Version** LTspice version XVII  
**Note**

The components shown below need to be defined in PARAMETERS (Figure 1).

- The capacitor Cosc from OSC pin to GND
- The resistor RVISD from VSD pin to GND
- The resistor RTISD from TSD pin to GND

In case of connecting OSC pin to GND, set Cosc=0.

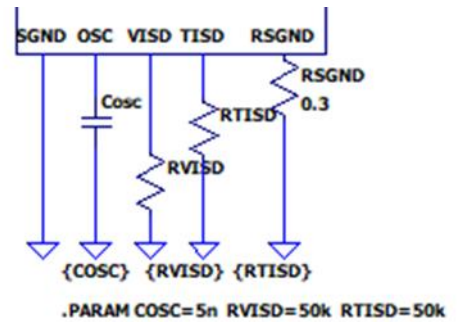

Figure 1. Setting Cosc, RVISD and RTISD

#### References

The information which was used for modeling is as follow:

[Data Sheet]

- Date/Version 2014-12-8
- Product name TB6642FTG
- Company name Toshiba Corporation
- Characteristics Transient, Transient2

#### Simulation Condition

This table shows the value of evaluated simulation condition that was not occurs any convergence problems in this area.

Item	Condition	Unit
Temperature	25	deg C

Simulation results are following.  
 Explanatory notes — : simulated

**Transient**

Temp. = 25deg C

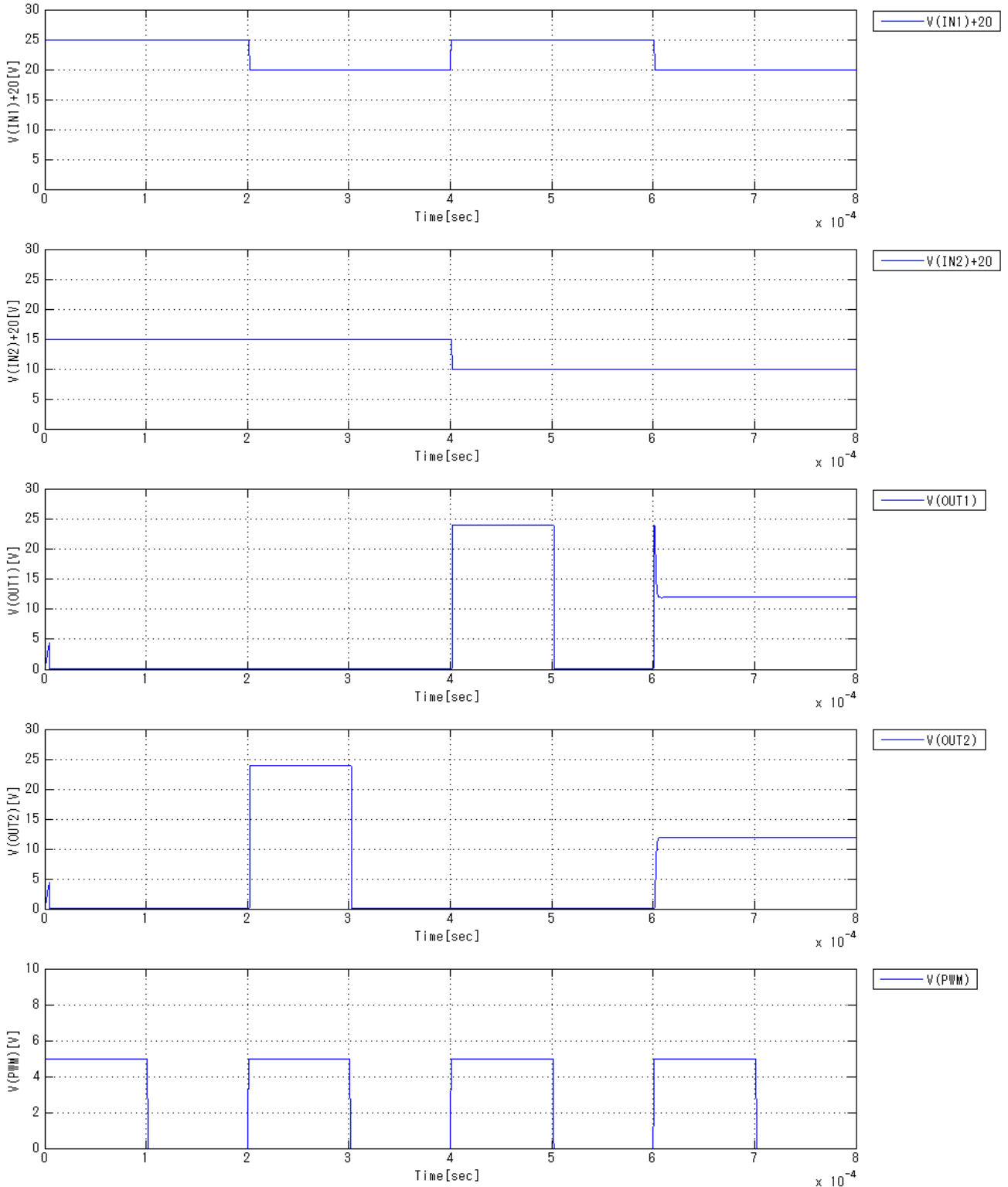

Simulation results are following.  
Explanatory notes — : simulated

**Transient2**

Temp. = 25deg C

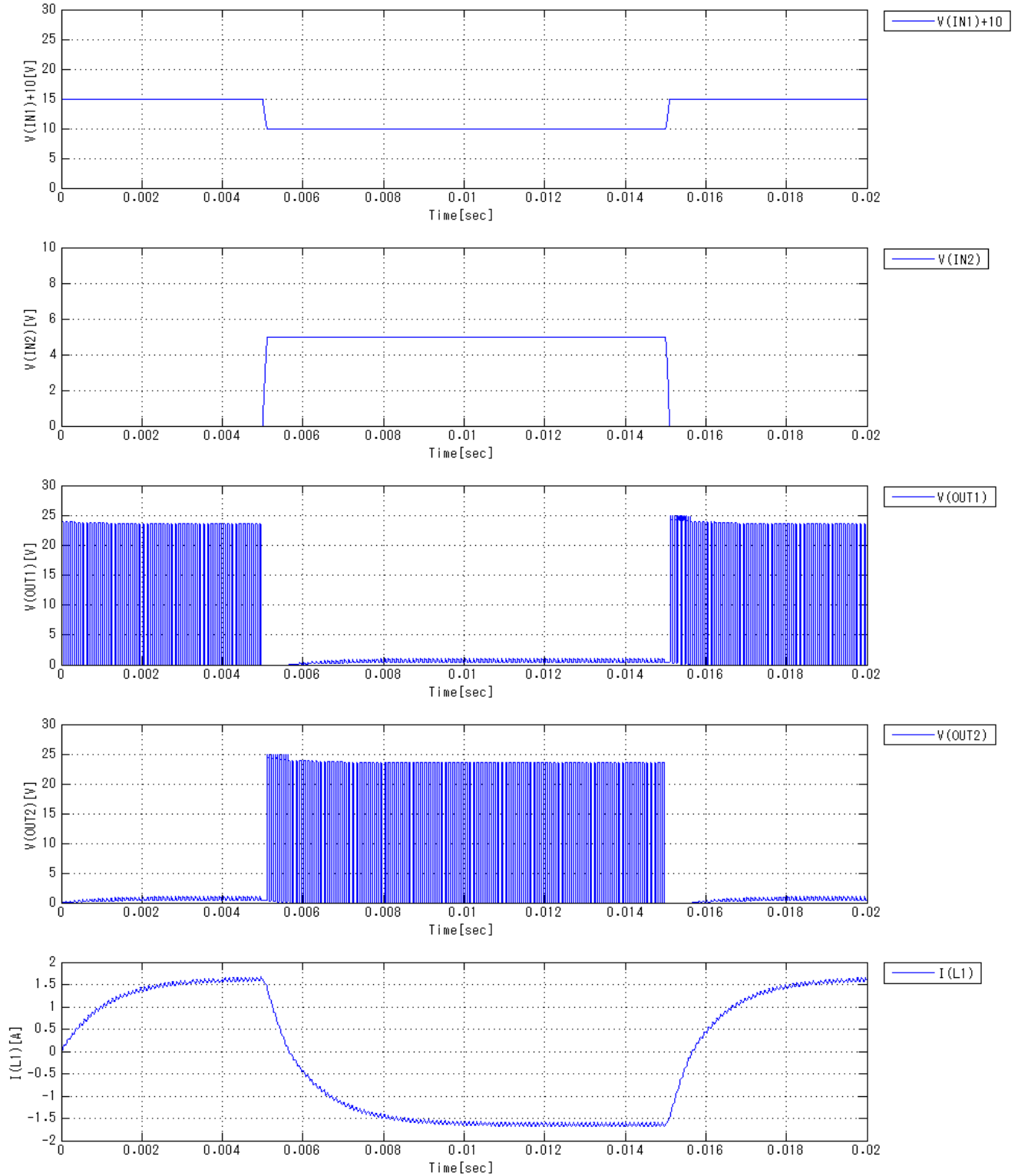

---

## DISCLAIMER

1. This SPICE (Simulation Program with Integrated Circuit Emphasis) model and its content (the "Contents") are copyright of MoDeCH Inc. All rights reserved. Any redistribution or reproduction of any or all part of the Contents in any form is prohibited without express written permission made by MoDeCH Inc.
2. MoDeCH Inc. as licensor (the "Licensor") hereby grants to you, as licensee (the "Licensee"), a non-exclusive, non-transferable license to use the Contents as long as you abide by the terms and conditions of this DISCLAIMER.
3. The Licensee is not authorized to sell, loan, rent and redistribute or license the Contents in whole or in part, or in modified form, to anyone.
4. The Licensor shall in no way be liable to the Licensee or any third party for any loss or damage (including ,but not limited to, lost profits, or other incidental, consequential, or punitive damages), however caused (including through negligence) which may be directly or indirectly suffered from, arising out of, or in connection with, any use of the Contents .
5. Notwithstanding anything contained in this DISCLAIMER, in no event shall Licensor be liable for any claims, damages or loss which may arise from the modification, combination, operation or use of the Contents with the Licensee's computer programs.
6. The Licensor does not warrant that the Contents will function in any environment.
7. The Contents may be changed or updated without notice. MoDeCH Inc. may also make improvements and/or changes in the products, pricing and/or the programs related to the Contents at any time without notice.



---

MoDeCH Inc.

Head Office

Location: 5-15 Yokoyama-cho, Hachioji-Shi, Tokyo 192-0081, Japan

Tel:+81-42-656-3360

E-Mail:[model-on-support@modech.co.jp](mailto:model-on-support@modech.co.jp)

URL:<http://www.modech.com/en/>