

LTspice Model

Power Clamper

Shindengen

ST03D-200-7001P12.5

Model Information

Model	A macro model	
Call Name	MDC_ST03D-200-7001P12_5_LT	
Pin Assign	1:Port1 2:Port2	
File List	Model Library	MDC_ST03D-200-7001P12_5_LT.lib
	Model Report	MDC_ST03D-200-7001P12_5_LT.pdf(this file)
Verified Simulator Version	LTspice XVII	
Note		

References

The information which was used for modeling is as follow:

[Data Sheet]

- Date/Version ST03D-200_Rev.01(2020.01)
- Product name ST03D-200-7001P12_5
- Company name Shindengen Electric Manufacturing Co., Ltd.

[Characteristics listed]

- Characteristics Breakdown Voltage – Temp
- Reverse Current – Temp
- Junction Capacitance - Applied Voltage

Simulation Condition

This table shows the range of evaluated simulation range that was not occurs any convergence problems in this area.

Item	Condition	Unit
Temperature	20	deg C

Model Functions Table

Functions	Implemented
Breakdown Voltage – Temp	<input type="radio"/>
Reverse Current – Temp	<input type="radio"/>
Junction Capacitance - Applied Voltage	<input type="radio"/>

Breakdown Voltage – Temp

TestBench

.meas VZT FIND V(VZ) WHEN -I(V1)=1m

.dc V1 180 300 1

.OPTION TNOM=25

.TEMP 0 10 50 75 100 125 150

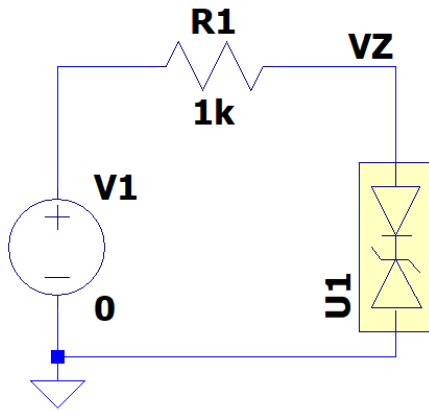

Simulation results are following.

Explanatory notes — : simulated

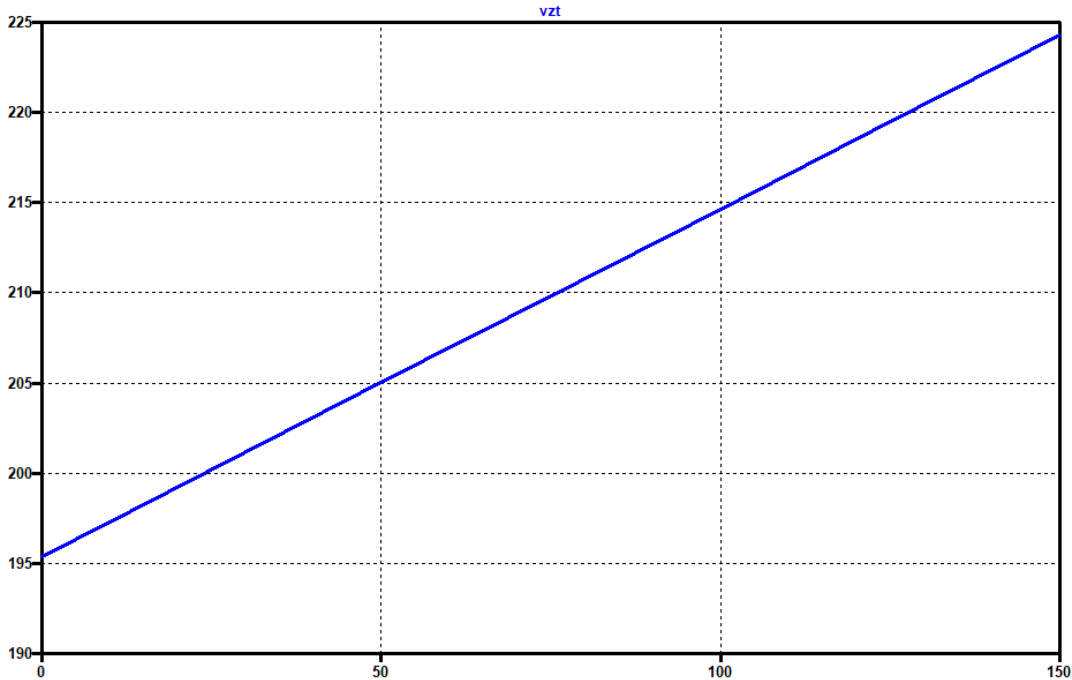

Reverse Current – Temp

TestBench

```
.op
.OPTION TNOM=25 GMIN=1e-15
.TEMP 25 50 75 100 125 150
```

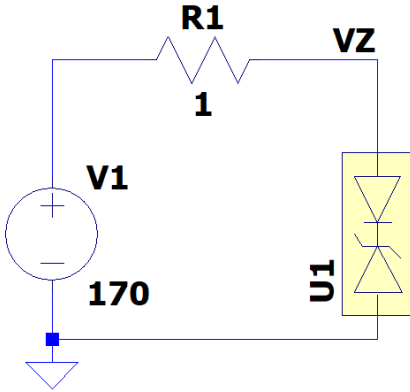

```
.op
.OPTION TNOM=25
.TEMP 25 50 75 100 125 150
```

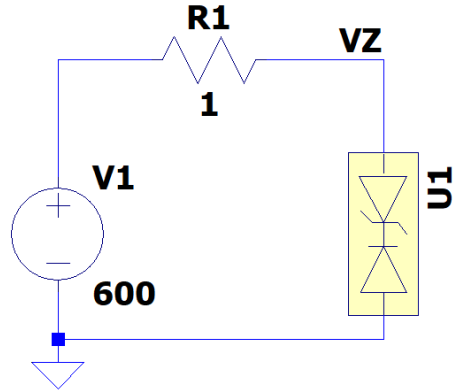

Simulation results are following.

Explanatory notes — : simulated

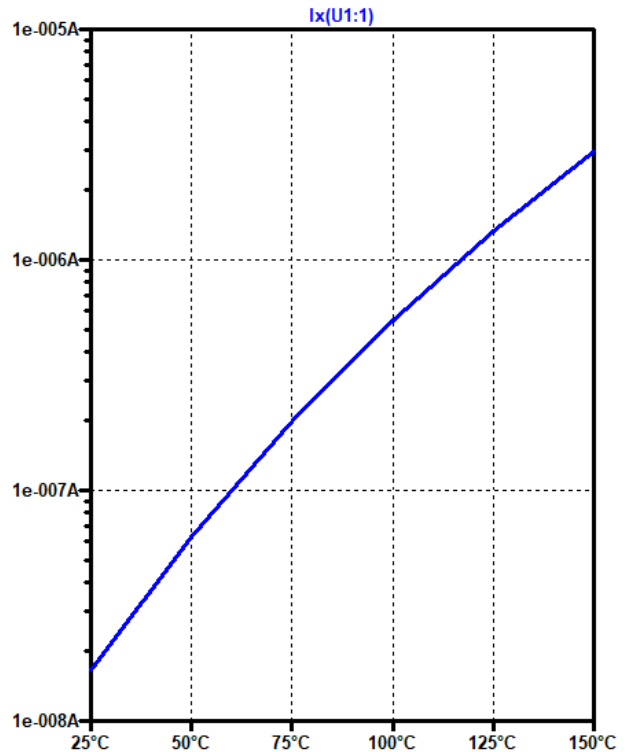
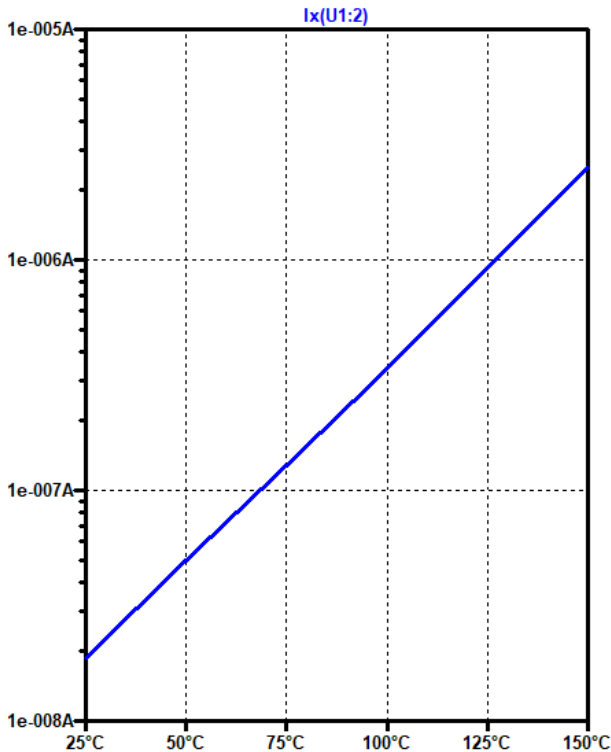

Junction Capacitance - Applied Voltage

TestBench

```
.step dec param VP 1 40 10
.ac lin 1 100k 100k
.OPTION TNOM=25 GMIN=1e-15
.TEMP 25
```

```
.step dec param VP 1 50 10
.ac lin 1 100k 100k
.OPTION TNOM=25 GMIN=1e-15
.TEMP 25
```

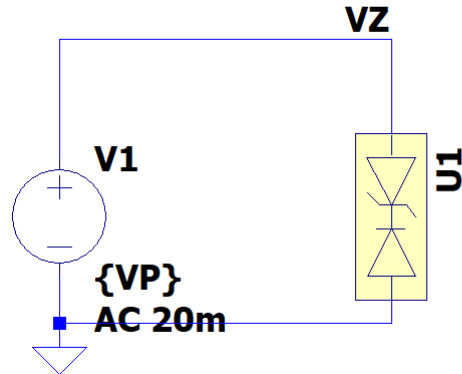
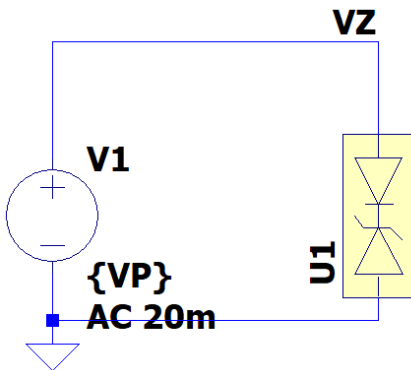

Simulation results are following.

Explanatory notes — : simulated

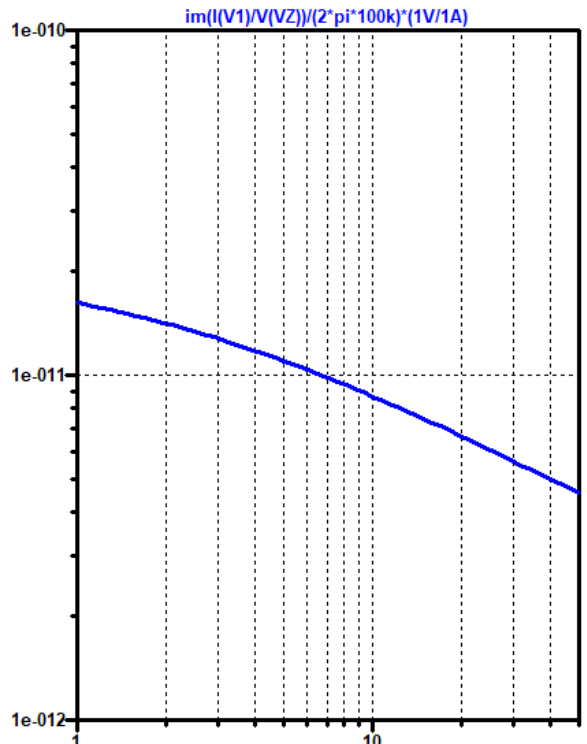
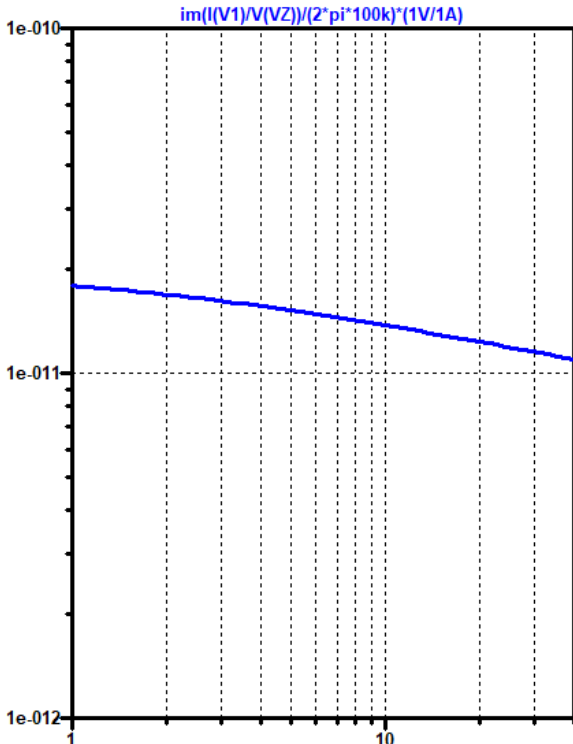

DISCLAIMER

1. This SPICE (Simulation Program with Integrated Circuit Emphasis) model and its content (the "Contents") are copyright of MoDeCH Inc. All rights reserved. Any redistribution or reproduction of any or all part of the Contents in any form is prohibited without express written permission made by MoDeCH Inc.
2. MoDeCH Inc. as licensor (the "Licensor") hereby grants to you, as licensee (the "Licensee"), a non-exclusive, non-transferable license to use the Contents as long as you abide by the terms and conditions of this DISCLAIMER.
3. The Licensee is not authorized to sell, loan, rent and redistribute or license the Contents in whole or in part, or in modified form, to anyone.
4. The Licensor shall in no way be liable to the Licensee or any third party for any loss or damage (including ,but not limited to, lost profits, or other incidental, consequential, or punitive damages), however caused (including through negligence) which may be directly or indirectly suffered from, arising out of, or in connection with, any use of the Contents .
5. Notwithstanding anything contained in this DISCLAIMER, in no event shall Licensor be liable for any claims, damages or loss which may arise from the modification, combination, operation or use of the Contents with the Licensee's computer programs.
6. The Licensor does not warrant that the Contents will function in any environment.
7. The Contents may be changed or updated without notice. MoDeCH Inc. may also make improvements and/or changes in the products, pricing and/or the programs related to the Contents at any time without notice.



MoDeCH Inc.

Head Office

Location: 5-15 Yokoyama-cho, Hachioji-Shi, Tokyo 192-0081, Japan

Tel:+81-42-656-3360

E-Mail:model-on-support@modech.co.jp

URL:<http://www.modech.com/en/>