

1500 g x 0.05 g

DIGITAL BALANCE

Model : GM-1500P



Your purchase of this DIGITAL BALANCE marks a step forward for you into the field of precision measurement. Although this DIGITAL BALANCE is a complex and delicate instrument, its durable structure developed. Please read the following instructions carefully and always keep this manual within easy reach.

OPERATION MANUAL

TABLE OF CONTENTS

1. FEATURES.....	1
2. SPECIFICATIONS.....	1
3. FRONT PANEL DESCRIPTION	3
3-1 Platform.....	3
3-2 CAL. Button (function A Button).....	3
3-3 Tare Button (function B Button).....	3
3-4 Display.....	3
3-5 Power Switch.....	3
3-6 Rubber Pads.....	3
3-7 Battery Cover/Compartment.....	3
3-8 DC 9V Receptacle	3
3-9 RS232 Output Socket.....	3
3-10 Unit Switch.....	3
4. PLATFORM INSTALLATION	4
5. WEIGHT MEASURING PROCEDURE	5
6. SELF-CALIBRATION.....	6
7. COUNTING SCALE OPERATION PROCEDURE.....	8
8. BATTERY REPLACEMENT.....	10
9. DC 9V AC/DC ADAPTER OPERATION.....	10
10. RS232 PC SERIAL INTERFACE	10

1. FEATURES

- * Microprocessor circuit with high accuracy & better performance.
- * 0.05 g & 0.002 oz resolution & wide measuring capacity.
- * Large LCD display, 18 mm (0.7") digit size, easy read out.
- * Built-in gram & oz display unit, select by the internal slide switch.
- * Built-in self calibration system, the calibration value can memorize into EEPROM circuit permanently even power off.
- * High precision counting scale function.
- * RS-232 computer interface.
- * Accept battery or AC/DC adapter power source, two way power supply.
- * Built-in " level bubble " & the adjustable " rubber pads ".
- * Heavy duty ABS housing plastic case.

2. SPECIFICATIONS

Display	LCD, 18 mm (0.7") digit size, 5 digits with annunciator.		
Measuring range & Resolution	<i>Unit</i>	<i>Range</i>	<i>Resolution</i>
	g	0.50 g to 1500 g	0.05 g
	oz	0.018 oz to 52.908 oz	0.002 oz
Min. Display Weight	g	0.50 g	
	oz	0.018 oz	
Unit Select	g or oz, select by internal slide switch.		

Accuracy	(0.05 % + 0.20 g) * <i>Within two hours after self calibration be executed.</i> 23 5 蚘 * <i>Spec. tested under the environment RF Field Strength less than 3 V/M & frequency less than the 30 MHz only.</i>	
Sampling time	Approx. 1 second.	
Tare Control	Approx. 1500 g max.	
Transducer	Load cell.	
Circuit	Microprocessor circuit.	
Auto Calibration	Use 500 g or 1000 g standard weight to execute self-calibration automatically.	
Operating Temperature	0 °C to 50 °C (32 °F to 122 °F).	
Operating Humidity	Less than 80% RH.	
Size	Cabinet	250 x 180 x 70 mm
	Platform	185 x 185 mm.
Power Supply	6 x 1.5V AA (UM-3) battery x 6 PCs, or DC 9V adapter, optional.	
Power Consumption	Approx. DC 25 mA.	
Accessory Included	Operation Manual 1 PC.	
Optional accessories	* Software (Windows version), SW-U101-WIN * RS232 cable, UPCB-01	

3. FRONT PANEL DESCRIPTION

Side view

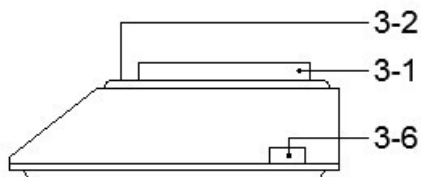

Bottom view

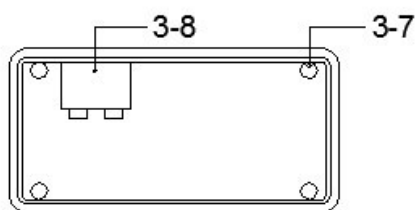

Front view

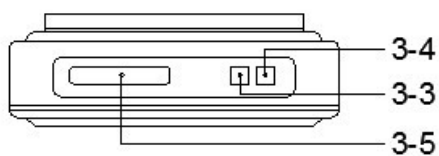

Back view

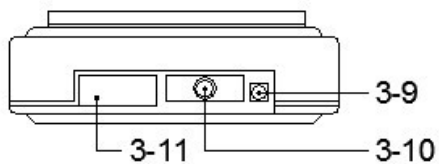

Fig. 1

- 3-1 Platform
- 3-2 CAL. Button (function A Button)
- 3-3 Tare Button (function B Button)
- 3-4 Display
- 3-5 Power Switch
- 3-6 Rubber Pads
- 3-7 Battery Cover/Compartment
- 3-8 DC 9V Receptacle
- 3-9 RS232 Output Socket
- 3-10 Unit Switch

4. PLATFORM INSTALLATION

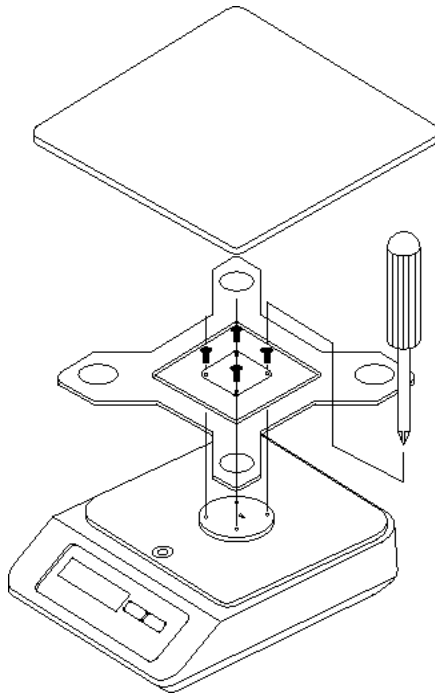

Fig. 2

5. MEASURING PROCEDURE

As intend to let the balance under the best operation condition, it recommend to warm up the balance at least 30 minutes before make the operation.

- 1) Place the balance on a flat hard surface.
- 2) Set the "g" or "oz" unit by slide the " Unit Switch " (3-10, Fig. 1).

**** The scale are set to the " g " unit typically.***

** Use the "-" type screw driver to slide the " Unit Switch ".*

** Slide the " Unit Switch " to the right position will set to " gram " unit & the right down corner of LCD will show the " g " marker.*

** Slide the " Unit Switch " to the left position will set to " oz " unit, but the LCD display will not show any marker.*

- 3) Turn the " Power Switch " (3-5, Fig. 1) to the " On " position.

1 = On, 0 = Off

The " Display " (3-4, Fig. 1) will show " 8.8.8.8.8 " for a few seconds, then " 0 " value (0.00 g for gram function, 0.000 for oz function) will be present.

- 4) Apply the load to the platform gently, display will show the measuring weight values.

** Do not exceed the over load capacity of the scale.*

** Over weighting, the display will show "-----".*

- 5) Tare function :

After weighting the first item, press " Tare Button " (3-3, Fig. 1), scale will reset to zero values automatically.

At the same time, the LCD display will show the " TARE " mark. Place next weighted item onto scale. Scale will give weights of the second only.

Consideration of tare function

- * *If the display show minus weight or show " _____ " means the display reading is under the zero, then tare function should be executed.*
- * *Before measuring the weight, If the display is not zero & show some value, it means the internal circuit is over the zero, then tare function should be executed.*
- * *The max. tare capacity is approx. 1500 g.*
- * *The " Tare " marker will disappear until power off and power on again.*

6. SELF-CALIBRATION

1) Please prepare the following optional " Standard Weight " :

500 gram standard weight (optional).
or 1000 gram standard weight (optional).

2) **Calibration under the 1000 gram standard weight**

- a) Power on the scale until the display show zero value.
Apply the 1000 gram standard weight to the center of the platform gently. If the scale is not accurate, then may show the weight value around 1000 g (for example 999.80 g , 1000.2 g.....)
- b) Step 1 :
Press the " CAL. Button " (3-2, Fig. 1) once, display will show the value of " 500.00 g "
Step 2 :
Following press the " Tare Button " (3-3, Fig. 1) once, display will show the value of " 1000.0 g "

Step 3 :

Press the " CAL. Button " (3-2, Fig. 1) once again, display value of " 1000.0 g " will flash 6 times, then the calibration procedures are finished completely & balance is ready for the measurement accurately.

3) **Calibration under the 500 gram standard weight**

- a) Power on the scale until the display show zero value. Apply the 500 gram standard to the center of the platform gently. If the scale is not accurate, then may show the weight value around 500 g (for example 499.75 g , 500.25 g.....)

b) Step 1 :

Press the " CAL. Button " (3-2, Fig. 1) once, display will show the value of " 500.00 g "

Step 2 :

Press the " CAL Button " (3-2, Fig. 1) once again, display value of " 500.00 g " will flash 6 times, then the calibration procedures are finished completely & balance is ready for the measurement accurately.

Consideration of Self-Calibration :

- * *The internal Self-Calibration value is saved to the internal EEPROM circuit permanently. Once power off then power on, the calibration value will be not disappeared .*
- * *After make the self calibration, measure the 500 g or 1000 g standard weight again, if the display value existing few counts deviation, it is normal. However within few hours, the balance will be kept under a high accuracy condition. Those accuracy will be even better than the published specification (refer page 2).*
- * *Under the status of " oz " unit, still can use the weight of 500 g or 1000 g to make the calibration. However the " g " marker will disappear.*

7. COUNTING SCALE OPERATION PROCEDURE

- 1) Prepare a lot of counting sample units. The no. of counting sample will be 10 PCs, 20 PCs, 50 PCs or 100 PCs.

The more PCs of counting sample will be better.

- 2) Step 1 :

- * ***No load to put on the platform.***

- * Use the finger to hold the " CAL. Button (function A Button) " (3-2, Fig. 1), at the same time set the " Power Switch " (3-5, Fig. 1) to the " On " position. Until the display show " 0.00 ", then release the finger away from " function A Button ".

- 3) Step 2 :

- * Push the " function A Button " (3-2, Fig. 1) once a while again, then the bottom left corner of LCD will show the " COUNT " marker. At the same time the LCD will show no. of sample units from 10, 20, 50, 100 in sequence & changed per second.
- * Put the counting sample units (For example 10 PCs, 20 PCs, 50 PCs or 100 PCs) on the platform.
- * Until the display reach the no. of sample units exactly, for example " 50 ", push the " function A Button " (3-2, Fig. 1) once a while. The display will flash twice and freeze the sample counting no., then take away the sample units. Now the balance is ready for counting.

Change to the new counting sample units

Under the counting version if intend to change the counting sample units, the new procedures are following :

- a. Take away any load from the platform.
- b. Push the " function A Button " (3-2, Fig. 1) once a while. LCD will show no. of sample units from 10, 20, 50, 100 in sequence & changed per second.
- c. Push the " Tare Button ", (3-3 Fig. 1) once.
- d. Put the counting sample units (For example 10 PCs, 20 PCs, 50 PCs or 100 PCs) on the platform. Until the display reach the no. of sample units exactly, for example " 50 ", push the " function A Button " (3-2, Fig. 1) once a while again. The display will flash twice and freeze the set counting no., then take away the sample units. Now the balance is ready for counting & the sample counting units already change to new value.

Consideration :

@ Under the counting function, 1 PC weight should large than 2.5 g, other wise the result of counting no. may existing some error.

@ The accuracy for the " counting no. " result are always depend on the no. of " sample units " that key in. We strong recommend that it can take more sample units as possible, for example 50 PCs or more, then will get the best accuracy.

4) Step 3:

- * **Take away the counting sample units away from the platform, then put the new lot of units that intend to be counted on the platform.**
- * **The display will show the counting no. of the new " sample units ".**

8. BATTERY REPLACEMENT

If battery is weak, LCD display will show " LO " indicator.

Every 5 second the " LO " indicator will flash one time.

This reminds user to replace new battery.

- 1) Open " Battery Cover " (3-7, Fig. 1) located at the bottom of the scale.
- 2) According to the device instruction, place batteries (1.5V AA size battery x 6 PCs) into the battery compartment & replace the battery cover.

9. DC 9V AC/DC ADAPTER OPERATION (Adapter is optional accessory)

- 1) The scale will also be operated by the household ACV power source (110/220/240 ACV) with a DC 9V AC/DC Adapter (capacity 300 mA).
- 2) Plug the jack from the Adapter into the " DC 9V receptacle " (3-8, Fig. 1).
- 3) Now the scale is ready for ACV operation.

10. RS232 PC SERIAL INTERFACE

The instrument features an RS232 output via 3.5 mm Terminal (3-7, Fig. 1).

The connector output is a 16 digit data stream which can be utilized to the user's specific application.

An RS232 lead with the following connection will be required to link the instrument with the PC serial input.

Scale (3.5 mm jack plug)	PC (9W 'D" Connector)
Center Pin.....	Pin 2
Ground/shield.....	Pin 5

The 16 digit data stream will be displayed in the following format :

D15 D14 D13 D12 D11 D10 D9 D8 D7 D6 D5 D4 D3 D2 D1 D0

Each digit indicate the following status :

D0	End Word
D1 & D8	Display reading, D1 = LSD, D8 = MSD <i>For example :</i> <i>If the display reading is 1234, then D8 to D1 is :</i> <i>00001234</i>
D9	Decimal Point(DP), position from right to the left 0 = No DP, 1= 1 DP, 2 = 2 DP, 3 = 3 DP
D10	Polarity 0 = Positive 1 = Negative
D11 & D12	Annunciator for Display g = 57 oz = 58 count = 30
D13	1
D14	4
D15	Start Word