

## Wall Clock - Large Display LED

### 810010 Instruction Manual

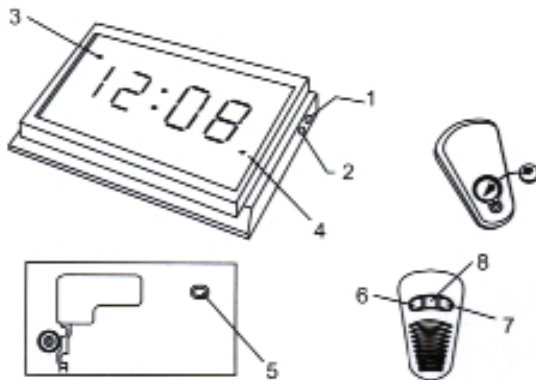

- |                               |                                     |
|-------------------------------|-------------------------------------|
| 1. Hour set button            | 5. Time / Alarm set button          |
| 2. Minute set button          | 6. Alarm ON / Hour button           |
| 3. Alarm On indicator         | 7. Alarm OFF / Minute button        |
| 4. Time / Alarm set indicator | 8. Snooze / Time / Alarm set button |

#### Connecting Power

To power the alarm clock, plug the provided AC adapter to the clock and the transformer into any AC outlet. The display will blink on and off for time/ alarm setting.

#### Manual Set Time And Alarm

##### Setting The Time

Slide the Time/Alarm set switch (5) to Time position, press the HOUR button (1) until the correct hour is displayed, then release the HOUR button (1) and press the MINUTES button (2) until the correct minute is display.

### **Setting The Alarm**

Slide the Time/Alarm set switch (5) to Alarm position, press the HOUR button (1) until the correct hour is displayed, then release the HOUR button (1) and press the MINUTE button (2) until the correct minute is displayed. Slide the Time/Alarm switch (5) back to Time position.

### **Remote Control Time and Alarm Set**

Important note: Whenever using the remote control unit, make sure that the Emitter points towards the clock.

### **Setting the Time**

Press the alarm off button (7) to turn off the Alarm On indicator. Press and hold Snooze/Time/Alarm set button (8) until Time/Alarm set indicator flashes. Keep pressing the button and, at the same time, press the HOUR (6) or MINUTE (7) button until correct time is displayed.

### **Setting The Alarm**

Press the Alarm On button (6) to turn on the Alarm On indicator. Press and hold Snooze/Time/Alarm set button (8) and follow the procedures same as at setting the time until the correct alarm time is shown.

### **Using Alarm On-Off**

When the Alarm On button is pressed, the Alarm On indicator (3) will light up and the alarm will sound at the time set. Press the Alarm Off button (7) to silence the alarm, and the Alarm On indicator (3) will go off.

### **Using Snooze**

When the alarm sounds, press the Snooze button (8) to get an extra 9 minutes of sleep. This can be repeated up to six times within an hour. If the Remote Control unit does not work properly, you may need to shorten the distance between it and the wall clock, or adjust the direction to get a better result.

### **Battery Replacement on Remote Control Unit**

If the unit does not work after being used for a period of time, you may need to replace the battery inside. Simply remove screw and battery cover at the back of it, and insert one CR2032 button cell into the battery compartment. Reinstall battery cover with screw.

### **Maintenance**

A soft cloth or a paper towel may be used to clean your clock. Do not use any corrosive cleanser solutions on the clock. Keep the cloth clean and dry to avoid any problems.