

Bluetooth® 4 Channel Datalogging Thermometer

800025

Instruction Manual

SPER
SCIENTIFIC

Environmental Measurement Instruments

TABLE OF CONTENTS

INTRODUCTION	3
BLUETOOTH® ADAPTOR INFORMATION	3
FEATURES.....	4
MATERIALS SUPPLIED	4
FRONT PANEL DESCRIPTION.....	5
LCD DISPLAY	6
SET UP	7
BLUETOOTH® ADAPTER INSTALLATION.....	12
MEASUREMENT PROCEDURES.....	13
SOFTWARE INSTALLATION.....	17
PROCESSING DATA WITH PC SOFTWARE	18
POWER SUPPLY	24
CARE AND MAINTENANCE.....	25
SPECIFICATIONS	26
WARRANTY	28

INTRODUCTION

This Sper Scientific Bluetooth® 4 Channel Datalogging Thermometer (Model 800025) displays data from four thermocouple probes simultaneously on a large backlit LCD. Up to 32,000 data records for each channel can be stored in the meter and saved, graphed and processed. The meter can stream both real-time and previously recorded data through Bluetooth® connectivity. This can be done on a computer using free software. The meter has the versatility to connect via Bluetooth® or the included USB interface. Real-time data can be logged in the field or with the meter connected to a computer.

FCC ID: 2AB7UBTXX0

This device and enclosed comply with part 15 of the FCC Rules. Operation is subject to the two following conditions: (1) this device may not cause harmful interference, and (2) this device must accept any interference received, including interference that may cause undesired operation.

FEATURES

- Four-channel simultaneous display
- Customizable High/Low Alarm on meter Channel 1
- Maximum/minimum/average values
- 4 Customizable High/Low Alarms from App
- Offset to compensate for probe errors
- T1 – T2 Δ Delta mode
- 32,000 data points stored per channel
- Direct upload of data to EXCEL, text, or graph files.
- Customizable data graphing
- Adjustable Automatic shutoff
- Backlight
- Bluetooth® streaming and data sharing
- iOS and Android APP available to download from APP store

MATERIALS SUPPLIED

- Datalogging Thermometer
- Micro USB Cable
- Two K-type Beaded Wire Probes
- Free Software Download at ***www.sperdirect.com***
- Instruction Manual
- Four AAA batteries
- Carrying Case
- Bluetooth® 7-pin adapter

FRONT PANEL DESCRIPTION

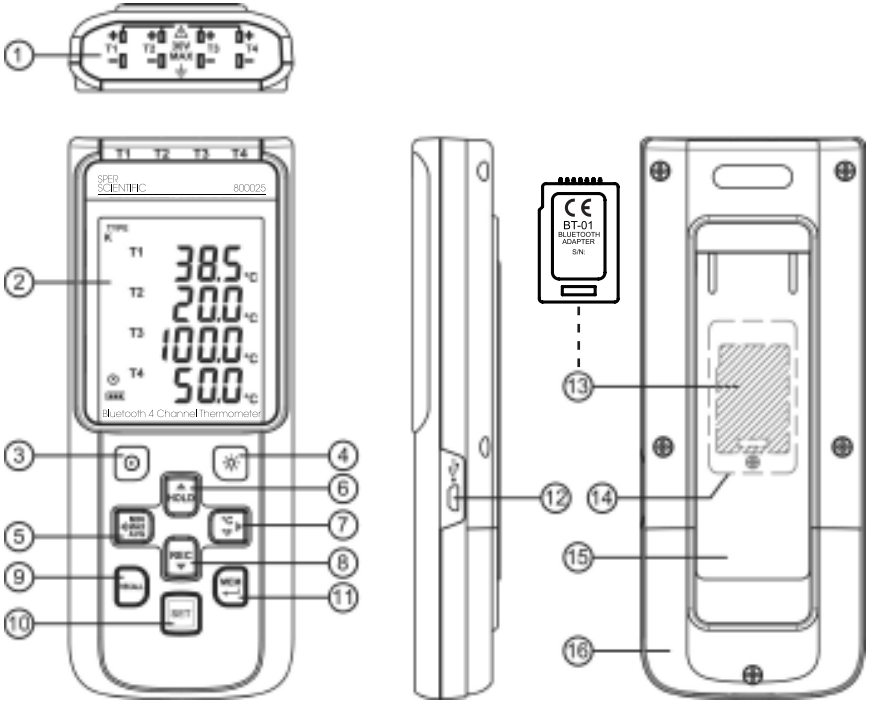

- | | |
|---------------------------------------|------------------------------------|
| 1. Thermocouple Input | 9. Recall Button |
| 2. LCD Display | 10. Enter / Setup Button |
| 3. Power Button | 11. Memory Button |
| 4. Backlight Button | 12. USB Interface/
Power Supply |
| 5. Maximum/Minimum/
Average Button | 13. Bluetooth® Adapter |
| 6. Data Hold Button | 14. Bluetooth® Compartment |
| 7. Temperature Unit
Selector | 15. Tilt Stand |
| 8. Record Button | 16. Battery Compartment |

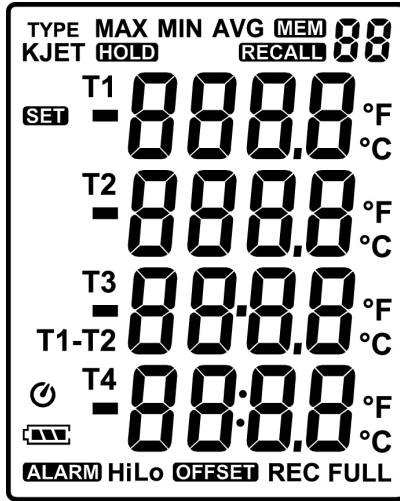

Low-Battery Icon

MIN

Minimum Reading

MAX

Maximum Reading

AVG

Average Reading

SET

Setup Mode



Automatic Shutoff Indicator

REC

Recording In Process

FULL

Memory Full Indicator

MEM 88

Save Reading In Memory

RECALL 88

Recall stored reading

TYPE KJET

Thermocouple type

-8888

Temperature reading

T1 T2 T3 T4

Temperature channel

T1 - T2

Δ Delta mode

ALARM

Alarm indicator

Hi

High temperature alarm

Lo

Low temperature alarm

OFFSET

Offset on to compensate for probe errors

°C °F

Temperature units

HOLD

Data hold indicator

LCD DISPLAY

SETUP

Note...

Install the Bluetooth® adapter as described on page 12.

Meter On and Off

1. Press **POWER** to turn the meter **on**.
2. Press and hold **POWER** for 3 seconds to turn the meter **off**.

Setup Mode

1. Press **POWER** to turn the meter **on**.
2. Press **SET** to enter Setup Mode.
3. Press **MEM** to save each setting choice and continue through the setup options.

Note...

After each change is made, pressing **SET** will also save the setting but will exit Setup Mode. The meter will return to Normal Mode if the **SET** button is pressed..

Bluetooth® Selection

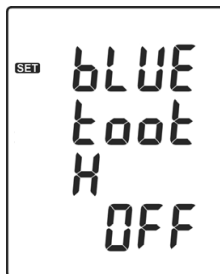

1. "bLUEtootH" appears on the display along with the word **on** or **off**. Press **▲** or **▼** to turn the Bluetooth® adapter **on** or **off**.
2. Press **MEM** to save the selection.

Thermocouple Type

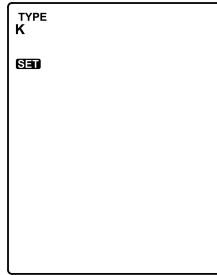

1. "Type" appears on the display along with the thermocouple type. Press ▲ or ▼ to cycle through K, J, E and T types.

Note...

The n, r, and s probe types will appear on the upper right side of the screen.

2. Press **MEM** to save the selection.

Time Interval



The time interval defines how often the meter will record a reading when it is in Record mode. You can set it to take readings from every 1 second to every 60 minutes 59 seconds.

1. "Int" appears on the display along with the time interval in minutes and seconds. The minutes flash on the display.
2. Press ▲ or ▼ to adjust the minutes.
3. Press ◀ or ▶ to enter the required number of seconds. The seconds will flash.
4. Press ▲ or ▼ to adjust the seconds.
5. Press **MEM** to save the selection.

Offset Values

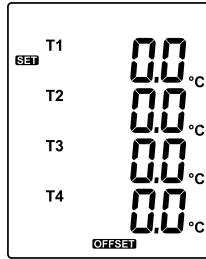

Thermometer readings can be adjusted to compensate for probe errors. The offset range is $\pm 5\text{ }^{\circ}\text{C}$ or $\pm 9\text{ }^{\circ}\text{F}$.

1. “T1” through “T4” appear on the display. Press ◀ or ▶ to cycle through the thermocouple channels.
2. Press ▲ or ▼ to increase or decrease the offset value.
3. Press **MEM** to save the selection.

Alarm

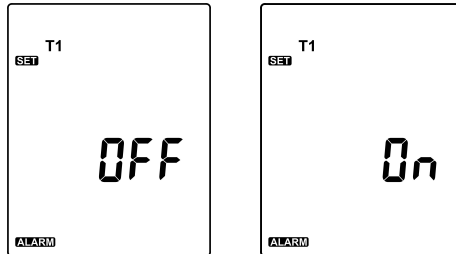

High and low alarm values can be set for channel T1. Within the App alarms can be set for all 4 Channels. Please see page 17.

1. “OFF” or “On” flashes on the display. Press ▲ or ▼ to toggle between alarm **off** and **on**.
2. With the alarm **on**, press **MEM** to set the alarm thresholds.

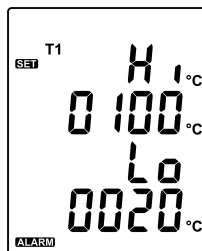

3. The first digit of the high alarm threshold flashes. Press ▲ or ▼ to increase or decrease the value.
4. Press ► to select the next digit.
5. Press ▲ or ▼ to increase or decrease the value.
6. Repeat steps 4-5 to set both the high and low alarm threshold values. Press ◀ if needed to return to a previous digit.
7. Press **MEM** to save the selection.

T1 - T2 Δ Delta Mode

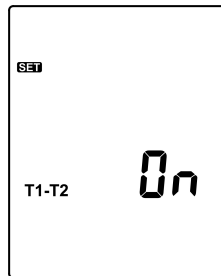
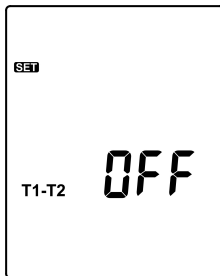

“OFF” or “On” flashes on the display. Press ▲ or ▼ to toggle between T1 - T2 Δ Delta Mode **off** and **on**.

Automatic Shutoff

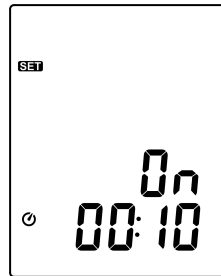
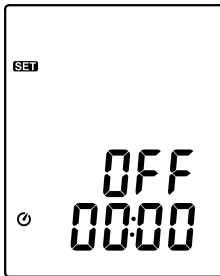

1. Press ▲ or ▼ to disable automatic shutoff or to select 10 or 30 minutes or 1, 2, 4, or 8 hours before automatic shutoff.
2. Press **MEM** to save the selection.

Date and Time

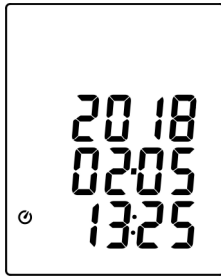

1. The date and time display and the year flashes. Press ▲ or ▼ to set the year.
2. Press ► to select the month. Press ◀ if needed to return to a previous selection.
3. Press ▲ or ▼ to set the month.
4. Press ► to select the day.
5. Press ▲ or ▼ to set the day.
6. Press ► to select the hour.
7. Press ▲ or ▼ to set the hour.
8. Press ► to select the minutes.
9. Press ▲ or ▼ to set the minutes.
10. Press **MEM** to save the selection.

BLUETOOTH® ADAPTER INSTALLATION

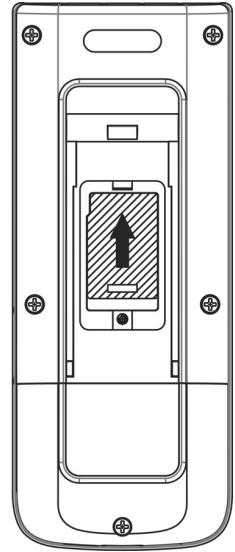
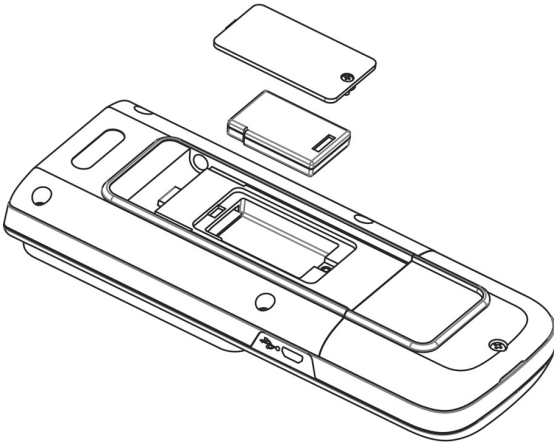

1. Lift the tilt stand to expose the single screw located behind the stand.
2. Remove the screw and plastic cover.
3. Place the Bluetooth® adapter into the housing with the label facing up.
4. Slide the adapter up to connect the pins of the adapter with the pins of the meter.
5. Screw the plastic cover back on to the meter.
6. The meter is now Bluetooth® capable.

Note...

While most Smartphones have built-in Bluetooth® capability, many PC's **DO NOT**. If the PC **DOES NOT** have Bluetooth® capability Bluetooth® Dongles are readily available through most retailers.

MEASUREMENT PROCEDURES

1. Insert the thermocouple(s) into the appropriate port(s).
2. Press **POWER** to turn the meter **on**.

Backlight

1. Press the backlight button to illuminate the LCD screen.
2. The backlight will shut off automatically after 30 seconds, or press the backlight button to turn it off sooner.

Select Temperature Units

Press **°C °F** to toggle between Celsius and Fahrenheit temperature units.

T1 - T2 Δ Delta mode

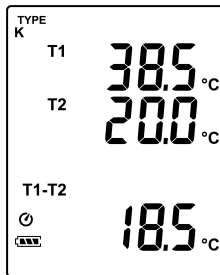

If T1 – T2 Δ Delta mode is selected the temperature difference displays on the lower right of the LCD.

Data Hold

Note...

The **MIN/MAX/AVG**, **°C °F**, **RECALL** and **SETUP** buttons on the meter are disabled during data hold.

1. Press **HOLD** to freeze the reading on the display. “Hold” appears at the top of the LCD.
2. Press **HOLD** to return to Normal Mode.

Maximum/Minimum/Average Mode

Note...

Viewing the maximum, minimum and average values will not interrupt temperature measurement. The maximum, minimum and average values will continue to be updated.

1. Press **MIN/MAX/AVG** to enter Maximum/Minimum Mode and record maximum, minimum and average values. “MAX” values are continually updated and displayed.
2. Press **MIN/MAX/AVG**. Minimum values are continually updated and displayed.
3. Press **MIN/MAX/AVG**. Average for the values are continually updated and displayed.
4. Press **MIN/MAX/AVG**. “MAX,” “MIN” and “AVG” blink. The meter displays real-time readings while continually updating its’ MIN/MAX/AVG records internally.
5. Press and hold **MIN/MAX/AVG** for 2 seconds to return to Normal Mode.

Recording Data

Note...

Most of the buttons on the meter are disabled during recording. All settings must be selected before recording begins.

1. Press **REC** to begin recording the readings. “REC” displays on the LCD. If 32,000 readings have been stored for a channel, “REC FULL” blinks on the LCD.
2. Press **REC** to stop recording.

Note...

The meter will not record if battery power is extremely low.

Note...

REC FULL stays on the display until the data is cleared. Computer can still access the data even though REC FULL is displayed.

Clearing the Recorded Data

1. Press and hold **POWER** for 3 seconds to turn the meter **off**.
2. Press and hold **REC**.
3. While continuing to hold **REC**, press and hold **POWER** to turn the meter **on**.
4. Continue to hold **REC** and **POWER**. The meter displays “REC,” “Clr” and “SUrE 5” and counts down to zero.
5. To exit the process without clearing the memory, release the **REC** and **POWER** buttons before “SUrE 0” displays.

Memory Function

To save a reading:

1. Press **MEM** to save the reading on the display.
2. The “MEM 88” symbol lights up for 2 seconds to show the next number of the saved reading, from 00 to 99.

To recall a reading:

1. Press **RECALL**. The “RECALL 88” symbol lights up on the display.
2. Use the ▲ or ▼ buttons to select a saved memory. The LCD shows the time of the reading for 2 seconds followed by the saved data.
3. Press **RECALL** to return to Normal Mode.

Clearing Readings in Memory

1. Press and hold **POWER** for 3 seconds to turn the meter **off**.
2. Press and hold **MEM**.
3. While continuing to hold **MEM**, press and hold **POWER** to turn the meter **on**.

4. Continue to hold **MEM** and **POWER**. The meter displays “MEM,” “Clr” and “SUrE 5” and counts down to zero.
5. “CLr 0” displays as the meter begins erasing records.
6. To exit the process without clearing the memory, release the **MEM** button before “SUrE 0” displays.

SOFTWARE INSTALLATION

System Requirements	Windows XP / VISTA / 7 / 8 / 10
Minimum Hardware Requirements	PC or laptop ≥50 MB hard disk space to install SE800024 Screen resolution ≥ 1024 x 768

Note...

Different computer systems may require slightly different installation steps than those below.

1. Download the software from the Sper Scientific website at ***www.sperdirect.com*** If Windows does not run the Setup.exe automatically, open the download folder and double-click the file from there.
2. Select **Yes** to allow the program Setup.exe to make changes to your computer.
3. Select **Next** to start the installation.
4. Select the folder to install the files and click **Next**.
5. Select the location for the program shortcuts and click **Next**.
6. Click **Next** to begin the configuration.
7. Click **Finish**. 800025 software is now installed along with a help file

Uninstalling the Software

If you wish to remove software from your computer, use one of the following methods. Note that your system may require slightly different steps.

1. Click on the **Start Menu**.
2. Select **Control Panel**.

3. Launch the **Add/Remove Programs**.
4. Highlight **800025**.
5. Click on **Add/Remove**.
6. Click **Next**.
7. Click **Next**.
8. Click **Finish**.

OR

1. Click on the **Start Menu**.
2. Select **Control Panel**.
3. Select **Programs and Features**.
4. Double-click on **800025**.
5. The Installation Dialog Box appears. Select **Uninstall** and click **Next**.
6. Click **Next**.
7. Click **Finish**.

PROCESSING DATA WITH PC SOFTWARE

Recording Real-Time Data in Graph Form

1. Press **POWER** to turn the meter on.
2. Connect the meter to the computer's Bluetooth®. This is different for some PC's, but is usually done through the settings menu under **Add a Device**. On some computers, the device may appear as both a headphone icon and a keyboard icon (see image). If this is the case, always choose the headphone icon.

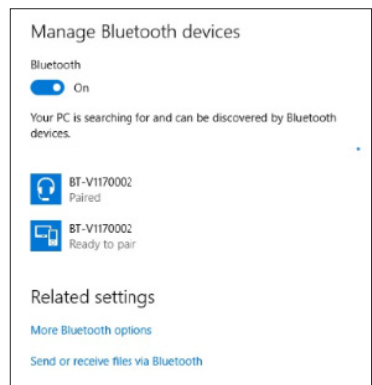



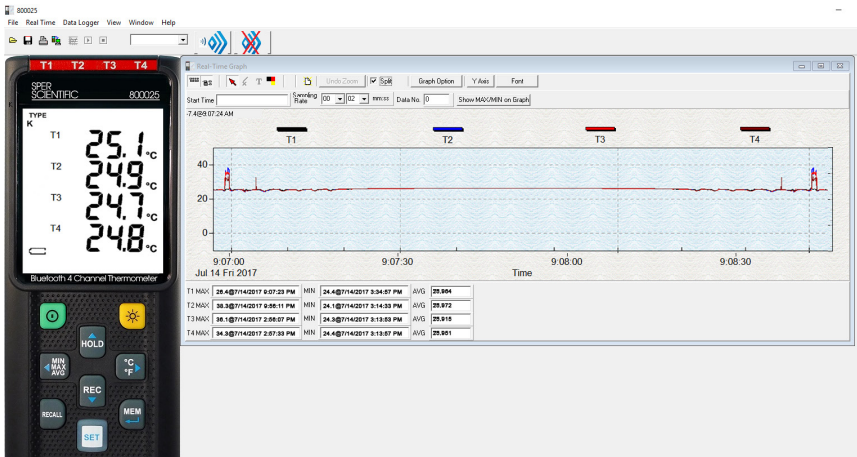





3. Insert the thermocouple(s) into the appropriate port(s)
4. Open the **800025 software**. An image of the meter displays along with a graph.
5. Connect the software to the meter by clicking the **Bluetooth® icon** (see the image, below). Please note that the meter's Bluetooth® must be on to connect to the software. Do this by following the instructions on page 7 of this manual. You can also connect the meter to the software by using the Micro USB cable.



6. The readings on the meter should display on the on-screen panel. If "No Connection" displays, close the software and check the following:
 - a. The meter's Bluetooth® is set to **On** in the meter's settings.
 - b. The meter is paired to the computer through the computer's device management.
 - c. The blue light on the paired meter will blink faster than that of other meters in the vicinity.
7. Click **Real Time** to begin recording real-time data.
8. Click **Run**. The Real-Time Setup Menu displays.

9. Enter the number of data points to record.
10. Enter the sampling rate.
11. Enter the recording period.
12. Click **Start** to begin recording and graphing.
13. Click  to end recording.

Tool Bar Options

	Connect to Bluetooth®
	Disconnect from Bluetooth®
	Hide or display the statistics above the graph (Statistic 1.)
	Hide or display the statistics below the graph (Statistic 2.)
	Restore normal cursor.
	Change cursor to an “X.” Click anywhere on the graph to mark it with an “X.” This option is not available when “Split” is selected.
	Change cursor to an “I.” Click anywhere on the graph to add an annotation. This option is not available when “Split” is selected.
	Set annotation color, ensuring sufficient contrast with the graph background.
Split	Separate or combine the four channels in the graph. When “Split” is not selected the graph will use T1 as the Y axis.



- Separate the four channels.

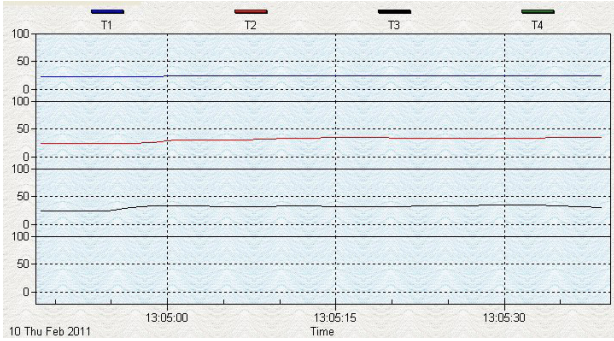

- Combine the four channels.

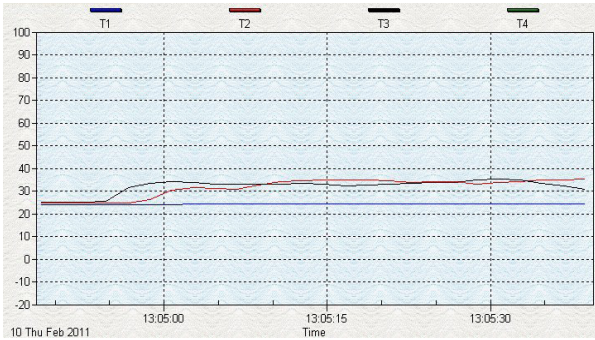

Viewing the Graph

- **To zoom in:** Press the left mouse button and drag the cursor to select the new area.
- **To zoom out:** Click **Undo Zoom**.

Customizing the Graph

1. Click **Graph Option** to open the **Customization Menu**.

This allows you to specify the channel displayed, modify the graph style, add a title and subtitle, maximize the graph and export the graph to the clipboard, a file or a printer.

Graph Option - Graph Customization

Y Axis - Change the Y axis extension

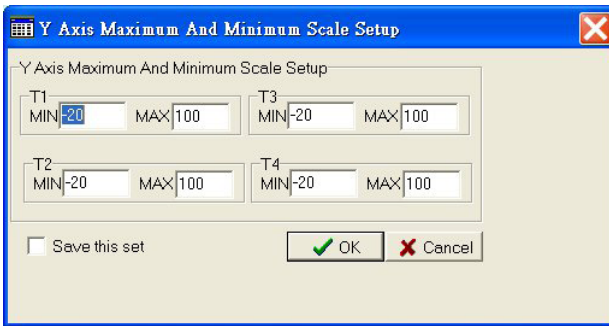

2. Click **Font** to select the font name, style and size for annotations.
3. Click **Y Axis** to customize the maximum and minimum values on the graph.

Saving Real-Time Data

1. Click the graph window you want to save. The selected graph window will become active.
2. Click **File** and select **Save**, or simply click the disc icon.
3. Enter the file name and file type extension:

File Type	Extension
Graph file. This file type can only be used in 800025.	*.ghf
Text file	*.txt
EXCEL format file	*.csv

4. Click **Save**.

Printing the Graph

1. Click **File** and select **Print**, or simply click the printer icon.
2. Select the destination printer and click **OK**.

Downloading Recorded Data

Select **Data Logger** from the main menu bar or click  (the datalogger icon) under the main menu. An indicator shows the loading progress.

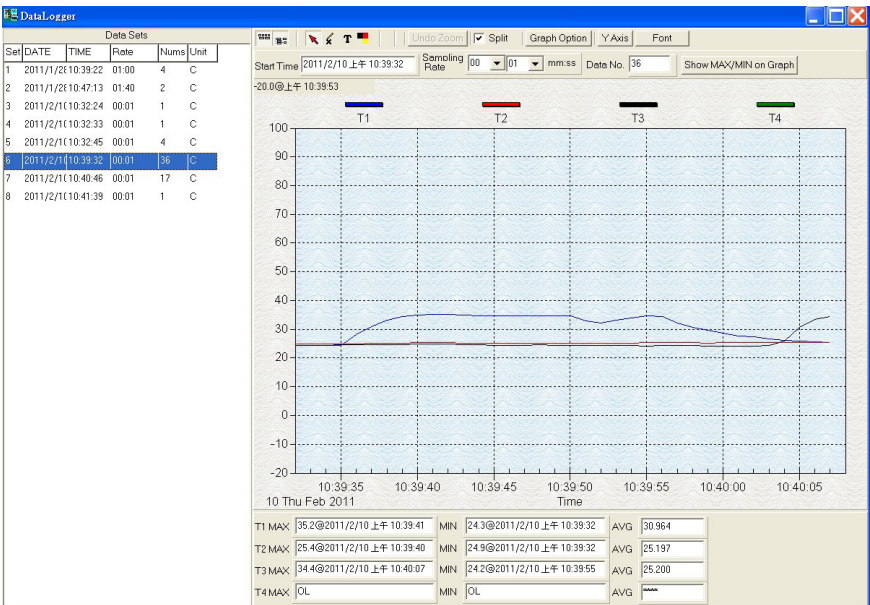
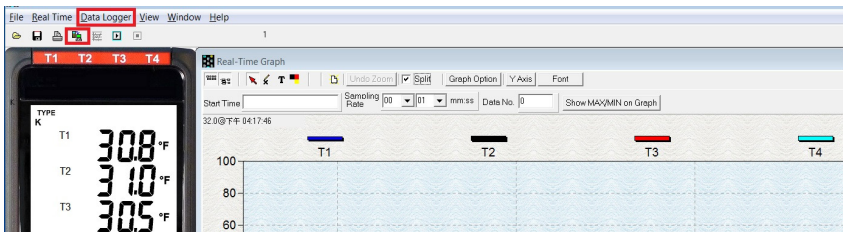

Data Sets										
Set	DATE	TIME	Rate	Nums	Unit	Coupl	T1 Offset	T2 Offset	T3 Offset	T4 Offset
1	2016/2/26	16:25:35	00:01	68	F	K	0.0	0.0	0.0	0.0
2	2016/2/26	16:26:49	00:01	26	F	K	0.0	0.0	0.0	0.0
3	2016/2/26	16:27:33	00:01	19	F	K	0.0	0.0	0.0	0.0
4	2016/2/26	16:28:03	00:01	77	F	K	0.0	0.0	0.0	0.0
5	2016/2/26	16:31:34	00:01	11	F	K	0.0	0.0	0.0	0.0
6	2016/2/26	16:31:49	00:01	24	F	K	0.0	0.0	0.0	0.0
7	2016/2/26	16:32:20	00:01	13	F	K	0.0	0.0	0.0	0.0
8	2016/2/26	16:32:39	00:01	13	F	K	0.0	0.0	0.0	0.0
9	2016/2/26	16:32:59	00:01	7	F	K	0.0	0.0	0.0	0.0

- The left side of the screen will display the number of data sets with detail information for each set.
- The first data set will appear in the graph on the right side.
- Click any data set to graph that set.

POWER SUPPLY

Battery Power

This meter uses four AAA batteries. To install the batteries before first use:

1. Lift the tilt stand on the back of the meter. Unscrew and remove the screw at the bottom of the battery cover.
2. Lift off the battery cover.
3. Insert four new AAA batteries, ensuring correct polarity.
4. Replace the battery cover and reinstall the screw.

Replace the batteries when the low-battery icon blinks on the LCD.

Note...

Before replacing the batteries, turn the meter **off** and disconnect the temperature probes.

CARE AND MAINTENANCE

- Periodically wipe the meter with a dry, lint-free antistatic cloth.
- Do not use abrasives, solvents or cleaning agents containing carbon, alcohol or benzenes on the meter.
- Repairs or services not covered in this manual should be performed by qualified personnel only. Please contact Sper Scientific to speak with a technician.

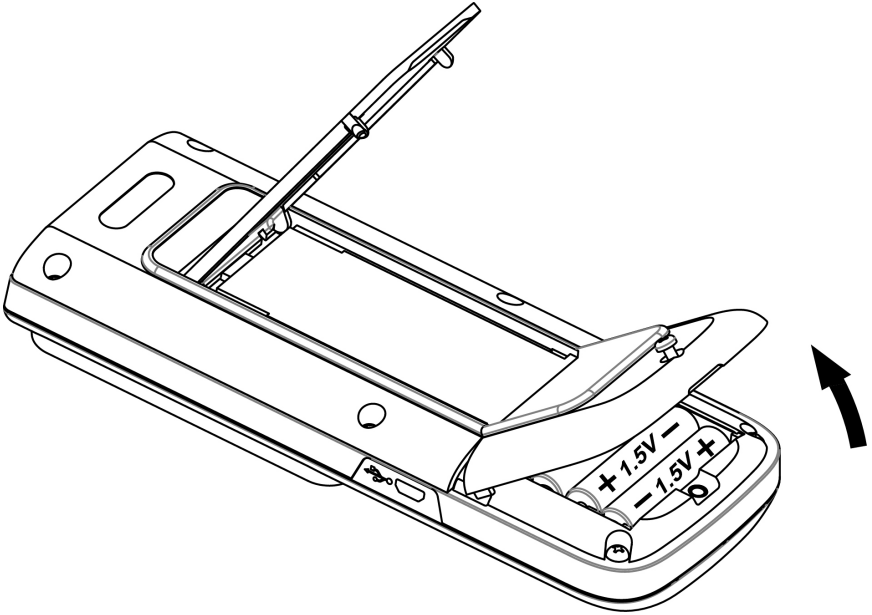

SPECIFICATIONS

		Range	Resolution	Accuracy (excluding probe error)
Temperature	K	-200 to 1372°C -328 to 2501°F	0.1°C < 600°C 1°C ≥ 600°C	±(0.1% of reading + 0.7°C) ±(0.1% of reading + 1.3°F) Below -100°C (-148°F) ±(0.5% of reading + 0.7°C) ±(0.5% of reading + 1.3°F)
	J	-200 to 1000°C -328 to 1832°F	0.1°F < 1000°F	
	E	-200 to 750°C -328 to 1382°F	1°F ≥ 1000°F	
	T	-200 to 400°C -328 to 752°F		
	N	-200 to 1300°C -328 to 2372°F		
	R/S	0 to 1767°C 32 to 3212°F	0.2°C < 600°C 1°C ≥ 600°C 0.5°F < 1000°F 1°F ≥ 1000°F	±(0.2% of reading + 1.4°C) ±(0.2% of reading + 2.5°F)
Temperature Coefficient		0.01% of reading + 0.05 °C (0.0028°F) per °C [<18°C (64°F) or >28°C (82°F)]		
Sample Rate		2 times per second		
Power Supply		UM-4 or AAA 1.5V battery x 4		
Battery Lifetime		Bluetooth® OFF : Approx. 100 hours (alkaline battery) Bluetooth® ON : Approx. 20 hours (alkaline battery)		
Operating RH%		10 to 90% RH (no condensing)		
Operating Temperature		0 to 50°C 32 to 122°F		
Operating Altitude		≤2000 meters		
Storage RH%		10 to 75% RH		

Storage Temperature	-20 to 60°C -4 to 140°F
Dimensions	7.36" x 2.95" x 114" (187 x 75 x 29 mm)
Weight	10.2 oz (290 g)

WARRANTY

Sper Scientific warrants this product against defects in materials and workmanship for a period of **five (5) year** from the date of purchase, and agrees to repair or replace any defective unit without charge. If your model has since been discontinued, an equivalent Sper Scientific product will be substituted if available. This warranty does not cover probes, batteries, battery leakage, or damage resulting from accident, tampering, misuse, or abuse of the product. Opening the meter to expose its electronics will break the waterproof seal and void the warranty. To obtain warranty service, ship the unit postage prepaid to:

SPER SCIENTIFIC LTD.

8281 E. Evans Rd., Suite #103
Scottsdale, AZ 85260
(480) 948-4448

The defective unit must be accompanied by a description of the problem and your return address. Register your product online at www.sperwarranty.com within 10 days of purchase.

